

# Parts and Service Manual

## Kerr KA-3500 Plunger Pump

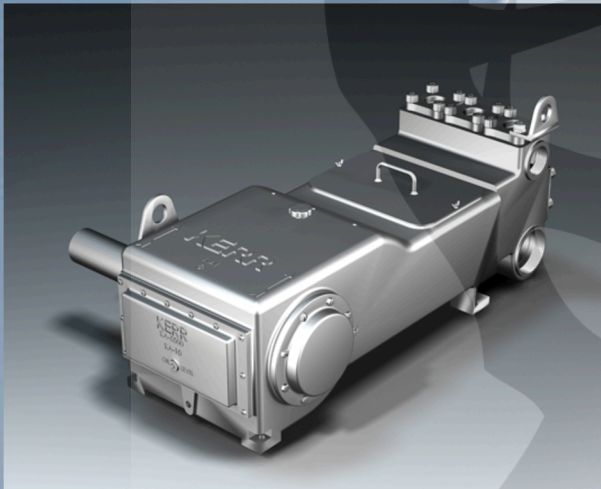

Post Office Box 735 2214 West 14th Street  
Sulphur, Oklahoma 73086  
Phone: 580-622-4207 Fax: 580-622-4206  
Website: [www.kerrpumps.com](http://www.kerrpumps.com)  
Email: [information@kerrpumps.com](mailto:information@kerrpumps.com)

United States and Canada  
800-441-8149

*Kerr Pumps*



*Since 1946*

BUCKHORN  
PUMPS, INC.

# KERR PUMP CORPORATION SERVICE MANUAL

NINETEENTH EDITION

## NEW PUMP WARRANTY

- A. Kerr Machine Co. (**Kerr Pump Corporation**) warrants its new pumps to be free from defective materials and/or workmanship for a period of one year from the date of sale by the Distributor, provided that the new pump is registered in accordance with Paragraph No. 2 hereof, properly installed and operated in accordance with the Company's Service Manual, and all other terms of this warranty agreement are complied with by the purchaser. As hereinafter provided, this warranty includes the replacement of parts and labor to correct any deficiency. All defective parts must be returned to the Company's Home Office for examination before this warranty is effective. This warranty applies to parts, which have been replaced under this warranty only so long as the original pump warranty is effective. This warranty is for the exclusive benefit of the purchaser and is not transferable.
- B. Each Distributor of a new pump will provide the customer with a registration blank furnished to him by the Company which must state the date of sale, be signed by the purchaser and the Distributor, and delivered to the Home Office of the Company within fifteen (15) days of the date of sale.
- C. In the event of a claim under this warranty, made within the one-year warranty period, the purchaser must notify the Distributor, and the Distributor shall contact **Kerr Pump Corporation** before any repairs or service calls are made.
- D. All warranty claims must be sent to **Kerr Pump Corporation** Home Office on the authorized warranty claim form provided by **Kerr Pump Corporation**, and available from the Distributor before any warranty claim will be considered. It is understood that **Kerr Pump Corporation** will deteriorate due to ordinary wear, therefore, the following credits shall apply to all replacement parts, labor, surface freight, travel time and mileage allowance furnished under this warranty.
  - i. For the first ninety (90) days from the date of sale by the Distributor, 100% credit will be allowed on a current list price basis.
  - ii. From 91 to 180 days from the date of sale by the Distributor, 75% credit will be allowed on a current list price basis.
  - iii. From 181 days to 270 days by the Distributor, 50% credit will be allowed on a current list price basis.
  - iv. From 271 days to one year after the date of sale by the Distributor, 25% credit will be allowed on a current list price basis.

*The credit given to the Distributor for replacement parts or pumps under this warranty is based upon the Distributor's net cost paid Kerr Pumps for such replacement parts or pumps.*

- E. In the event of a warranty claim under this warranty made within ninety (90) days of the date of sale by the Distributor, **Kerr Pump Corporation**, before any repairs are made, shall be contacted by the Distributor and given the option of having the Distributor either repair or replace the pump.
- F. Upon any claim under this warranty, other than a claim wherein Kerr Pump Corporation at its option replaced the pump as provided in Paragraph No. 5 hereof, the Distributor will make the necessary repairs an/or replacement, and Kerr Pump Corporation shall allow the cost of labor on warranty claims. The labor cost may include travel time not to exceed (8) hours of actual travel time. Kerr Pump Corporation will pay surface freight on warranty shipments. After making the necessary repairs and/or replacements, the Distributor will bill the customer for the full amount due for the repair. Thereafter, the Distributor will submit the warranty claim form provided by **Kerr Pump Corporation** to the **Kerr Pump Corporation** Home Office for consideration. In the event the warranty claim is honored by **Kerr Pump Corporation** a Credit Memorandum will be issued to the Distributor in the amount determined by the table in Paragraph No. 4 hereof. Thereafter, the customer's invoice will be credited by the Distributor in the same percentage allowed the Distributor by **Kerr Pump Corporation**.  
If requested by **Kerr Pump Corporation** the purchaser or the Distributor shall return the alleged defective product to **Kerr Pump Corporation** factory, freight prepaid, for examination and testing. If **Kerr Pump Corporation** determines the product is defective **Kerr Pump Corporation** will either repair or replace such product with a like of **Kerr Pump Corporation** manufacture, f.o.b. to the Distributor or allow the Distributor credit to an amount equal to the invoiced value of the defective product. The responsibility of **Kerr Pump Corporation** is limited to the repairing or replacing defective material manufactured by it, provided **Kerr Pump Corporation** examination discloses to its satisfaction that such material has not been altered or repaired, other than by **Kerr Pump Corporation** approved procedures, subject to misuse, improper maintenance, negligence or accident. **Kerr Pump Corporation** will not be responsible for loss of liquid or for damage of any kind, or from any cause, to any person or property of any person, or for loss of revenue of profit, or for any other special incidental or consequential damages.
- G. The warranty applies only to new **Kerr Pump Corporation**. The Company specifically excludes from this warranty the following.
- i. All plungers, valves, plunger packing, valve springs, seals gaskets, and corrosion and/or erosion damage caused by the fluid handled by the Company's pump.
  - ii. In addition, after the expiration of the pump warranty all replacement parts are no longer in warranty.
- H. In extreme cases where in the opinion of **Kerr Pump Corporation**, if a pump has been misused or is being misused, **Kerr Pump Corporation** reserves the option to offer to redeem the pump from the purchaser. Should the purchaser refuse to allow the pump to be redeemed and chooses to continue improper operation, the warranty will be void.
- I. Any parts or equipment which **Kerr Pump Corporation** supplies and does not manufacture shall be subject only to the warranties of **Kerr Pump Corporation** vendors to the extent **Kerr Pump Corporation** can enforce such warranties.
- J. Any repairs to, alterations of, or work done on alleged defective products without **Kerr Pump Corporation** specific written authorization shall void **Kerr Pump Corporation** warranty applicable thereto.
- K. Any action for breach of warranty or other action under this agreement must be commenced within (1) year after such cause of action arises.

***This limited warranty is in lieu of all other warranties, expressed or implied, including any implied warranty or merchantability or fitness.***

## TROUBLESHOOTING GUIDE

Problem	Reason/Solution
Unusual pounding, knocking broken valve spring	<ul style="list-style-type: none"><li>• Insufficient fluid at high speed.</li><li>• Suction line is improper size or is constricted. (Trash in line, valve partly opened, etc.)</li><li>• Possibility of gas in the fluid causing the roughness.</li></ul>
Loss of pressure or volume	<ul style="list-style-type: none"><li>• Foreign matter may be holding valves open.</li><li>• Worn valves.</li><li>• Broken springs.</li></ul>
Consistent, rhythmic knock	<ul style="list-style-type: none"><li>• Improper bearing adjustment.</li><li>• Worn bearings or connecting rods.</li><li>• NOTE: Valve noise is common and normal in high-speed pumps. It should not cause concern unless it becomes erratic.</li></ul>
Packing failure (Excessive)	<ul style="list-style-type: none"><li>• Improper installation.</li><li>• Improper type of lubrication.</li><li>• Incorrect type of packing for particular installation.</li><li>• (Contact <b>Kerr Pump Corporation</b> if you are unsure.)</li></ul>
Abnormal wear of fluid end parts	<ul style="list-style-type: none"><li>• Abrasive or corrosive fluid.</li></ul>
Abnormal wear of power end parts	<ul style="list-style-type: none"><li>• Lack of oil, overload on pump, foreign matter in oil.</li></ul>
Heat in power end	<ul style="list-style-type: none"><li>• A new pump will run hot for a short period (2 or 3 days). See above for persistent heating. Pump will operate near 140° F. under average conditions.</li><li>• Check for air in pump by bleeding at cover caps.</li><li>• Too much spring tension Reciprocating pumps have very limited pick up.</li></ul>

## INSTALLATION INSTRUCTIONS



### WARNING

**Read everything in this section before attempting to run or connect your pump.**

The importance of proper installation cannot be overstressed. As the reciprocating pump is almost unable to lift fluid, proper suction flooding is a must. This is the First step toward satisfactory operation.

BUCKHORN  
PUMPS, INC.



The Kerr Pumps Engineering Service will be happy to advise you in your installation problems. As almost every installation varies, you cannot exercise too much care in making certain your installation is proper.

Before Starting The Pump, read carefully the maintenance section in the following pages.

**For best results, follow these installation guidelines.**

- (A) PRESSURE RELIEF VALVE (REQUIRED)
- (B) BY-PASSED FLUID SHOULD BE PIPED BACK IN SUCTION SUPPLY TANK WHEN POSSIBLE
- (C) USE FLEXIBLE HOSE IN DISCHARGE LINE WHEN POSSIBLE
- (D) DISCHARGE SHUT-OFF VALVE (OPTIONAL-USED FOR TOTAL SHUT-DOWN OR SERVICE ONLY)
- (E) DISCHARGE AND SUCTION ON EITHER SIDE OF FLUID END ON ALL MODELS.
- (F) PULSATION "DAMPENERS" MAY BE USED IN EITHER THE SUCTION OR DISCHARGE PIPING OR BOTH. DISCHARGE DAMPENERS SHOULD BE CAPABLE OF HANDLING PUMP DISCHARGE MAXIMUM PRESSURE

To start the pump, open the suction line valve and permit the intake chamber to fill on the pump. Air may be bled off by opening the valve covers slightly until there is a constant fluid flow. After bleeding, open the discharge line valve and start the pump. Roughness may occur from cavitation (air in line) or from starvation (lack of fluid). Eliminate these troubles before permitting continuous operation.

BUCKHORN  
PUMPS, INC.

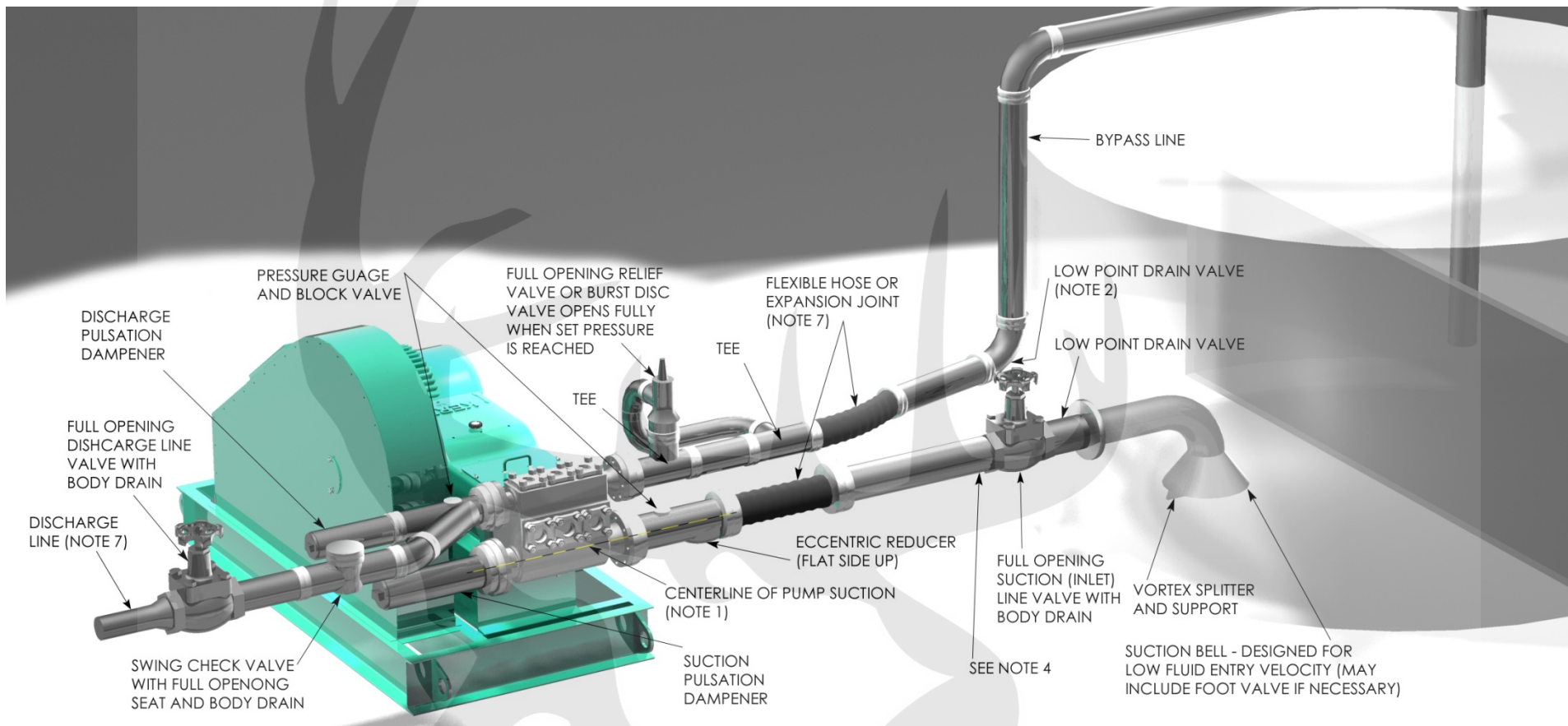

- 1) CENTERLINE OF PUMP SUCTION (INLET) TO BE SLIGHTLY HIGHER THAN CENTERLINE OF SUCTION (INLET) VALVE - SO ANY AIR IN SUCTION SYSTEM PROMPTLY REACHES PUMP AND IS EXPELLED
- 2) SLOPE BYPASS LINE SO LOW POINT DRAIN WILL FULLY EMPTY RELIEF AND CHOKE VALVES AND ALL LIQUID IN BYPASS CIRCUIT
- 3) DO NOT LOCATE PIPING OR OTHER EQUIPMENT IN FRONT OF OR ABOVE PUMP FLUID END PREVENTING SERVICING - REFER TO MANUFACTURER FOR MINIMUM CLEARANCES
- 4) LOCATE CHARGING PUMP AT POINT SHOWN. - IF CHARGING PUMP IS NECESSARY (FOR VOLATILE FLUIDS, FOR EXAMPLE)
- 5) IF DESIRED, A TWO-WAY MOTOR OPERATED BYPASS VALVE MAY BE USED RATHER THAN MANUAL TYPE - IT SHOULD BE DESIGN TO OPEN AUOMATICALLY WHILE STARTING OR STOPPING
- 6) BYPASS LINE SHOULD FEED LIQUID INTO TANK BELOW MINIMUM LIQUID LEVEL
- 7) TO REMOVE PIPING STRAIN AND VIBRATION A FLEXIBLE HOSE, EXPANSION JOINT OR SWIVLE JOINT PAIR SHOULD BE POSITIONED TO MINIMIZE EFFECTS OF PIPING THERMAL EXPANSION, CONTRACTION AND PIPING WEIGHT
- 8) SUCTION SIZED FOR 1 1/2 TO 2 FT/SEC MAX FLOW RATE. DISCHARGED SIZED FOR 8 TO 10 FT/SEC MAX FLOW RATE - SUCTION AND DISCHARGE MUST BE SUPPORTED AND ANCHORED
- 9) TO PROTECT SUCTION SYSTEM AGAINST HAZARD OF DISCHARGE PRESSURE ENTRY (AS WHEN PUMP IS IDLE), A SMALL RELIEF VALVE IS OFTEN CONNECTED HERE
- 10) ALL SYSTEM COMPONENTS MUST HAVE ADEQUATE PRESSURE RATINGS FOR OPERATING, STARTING AND UPSET CONDITIONS. IN ORDER TO REDUCE POTENTIAL HAZARDS, PARTICULAR ATTENTION IS RECOMMENDED FOR THE SURGE CONDITION THAT WILL RESULT DOWNSTREAM OF THE RELIEF VALVE WHEN NORMAL DISCHARGE IS BLOCKED



-AS A GENERAL RULE, FLUID LEVEL MUST BE HIGHER THAN THE PUMP FLUID END AS PLUNGERS CANNOT LIFT FLUID. 10 FEET OF HEAD IS A GOOD RULE OF THUMB.

-CAUTION SHOULD BE TAKEN TO KEEP FITTINGS OUT OF THE SUCTION AND DISCHARGE PIPING AS THESE WILL RESULT IN POOR PERFORMANCE. EACH 90-DEGREE TURN IN THESE LINES RESULTS IN GREAT LOSS OF PUMPING EFFICIENCY.

BUNKER HORN  
PUMPS, INC.

## PREVENTIVE MAINTENANCE

### DAILY

#### A. Check and Maintain Lubricant Levels.

##### **Standard Lubricant:**

AGMA Grade (ASTM D 2422): 4 EP

ISO Viscosity Grade: 150

Viscosity in SSU @ 100 degree F: 625-765

##### **Synthetic Lubricant:**

SAE Viscosity Grade (J306-8): 75W-90

### MONTHLY

- A. Drain and refill crankcase. It is recommended that oil be changed after the first week of operation.
- B. Wash oil filler cap in kerosene.
- C. Check valves for excessive wear, broken or bent springs, etc.
- D. Check crankshaft bearings for endplay. (See section on crankshaft)
- E. Keep all nuts, studs, etc. tight.
- F. Check valve covers for leaks.
- G. Check all seals and gaskets for leaks

### PUMP CAPACITIES (APPROXIMATE)

KD-1250	2 qts.	KT-3350	16 qts.
KJ-2250	3 qts.	KT-3400	16 qts.
KZ-3150	2 qts.	<i>Use SAE 30 weight non-detergent motor oil ONLY</i>	
KM-3250	4 qts.	KB-3500	20 qts.
KM-3300	4 qts.	KA-3500	24 qts.
KP-3300	12 qts.	KSB-6400	36 qts.
R335/R340	16 qts.	KSB-6500	36 qts.
Q5450	22.5 gal.	KCP-6300	24 qts.

BUCKHORN  
PUMPS, INC.

## PLANETARY GEAR REDUCERS

#6	17 ozs.
#8	42 ozs.
#9	42 ozs.

- B. If pump has lubricating facilities for stuffing boxes, check level of lubricant.
- C. Maintain packing gland tension on packing (Do not over-tighten)
- D. Visually inspect pump for apparent trouble.
- E. Keep the pump clean.

## GENERAL

Replace any work part before its eventual failure. Use the following instructions for removal and replacement of parts. Don't hesitate to call on **Kerr Pumps** for help if necessary.

## SERVICE PROCEDURES (ALL MODELS)

### A. WING GUIDED VALVES

- i. **DISCHARGE VALVES:** The discharge valve and seat can be exposed by first removing the discharge valve cover cap. Once the discharge cover cap has been removed you may lift out the discharge valve spring and the discharge valve. The valve seat will be held in place by a taper fit and must be "pulled" with an appropriate valve-pulling tool (available from the **Kerr Pumps** Dealers). Once the valve and seat have been removed they should be resurfaced or replaced if badly worn. To replace the discharge valve, first clean and inspect the seat bore for washout defects and then drop the seat into the bore. Replace the valve into the seat and strike the top of

the valve a couple of good blows utilizing a brass bar and hammer to seat the valve seat in the fluid end valve bore. Replace the valve spring and cover cap after inspecting the spring and the seal of the cover cap.

- ii. SUCTION VALVES: The suction valves are located in the chamber directly below the suction or end valve cover caps. The suction valves are serviced in the identical manner as the discharge valves. Note: Discharge valves must be removed prior to any removal of the suction valves.

### ***Service Procedure for KZ-3150 Valves***

- iii. DISCHARGE VALVES: The discharge valve and seat can be exposed by first removing the discharge valve cover plate. Once the discharge cover cap has been removed you may lift out the discharge valve spring, discharge valve and valve seat. Once the valve and seat have been removed they should be replaced if badly worn. To replace discharge valve, first clean and inspect the seat bore for wash out defects and then drop the seat into the bore. Replace valve in seat then valve spring and cover cap, always-inspecting o'ring seals between seats and cover caps.
  - iv. SUCTION VALVES: The suction valves are located in the chamber directly below the discharge valve seat. The suction valves are serviced in the identical manner as the discharge valves.
- B. DISC TYPE VALVES: All disc-type valves are exposed for removal in a similar manner as the wing-guided valves. Instead of removing the valve body; the upper portion of the valve is removed by removal of the valve capscrew, spring retainer, valve spring, and valve spacer sleeve. The valve seat is then "pulled" from the fluid-end utilizing an authorized Kerr Valve Puller. Note: In all **Kerr Pumps** with disc-type valves the discharge and suction valves are identical.
- C. BALL AND SEAT VALVES: In pumps with block/billet type fluid-ends the valves are ball and seat design. These are exposed for removal/inspection by removal of the appropriate valve cover. The flat seats are kept in place by a screw-in valve retainer that can be best removed with a Kerr Valve Wrench made for the appropriate pump. Springs are normally incorporated with the discharge valves while the suction valves operate with a "free ball". A copper washer/gasket is used under all valve seats for a seal. When installing or removing a flat type valve seat a good "rap" on top of the valve wrench will "seat/unseat" the seat and copper gasket prior final tightening or removal. Failure to "seat" the valve seat in this manner can result in the "washing out" of the fluid-end. For *pressurized suction*, valves will need to be spring loaded. Call **Kerr Pumps** for this change.
- D. PLUNGERS: Following the removal of the suction valve, the plunger may be removed by breaking the union between the plunger and pony rod and forcing the plunger out the back of the fluid-end. Loosening the packing nut/gland will facilitate the removal of the plunger. The reverse of this procedure is used to install a plunger. Lubrication and some slight force may be used to pass plunger through the packing.



Always retighten the plunger and pony rod union periodically following the removal of the plunger to insure it is securely made up and will not vibrate loose.

- E. **PLUNGER PACKING:** This manual includes illustrations of the packing sets for each model pump. Generally, once the plunger has been removed from the pump, the packing can be exposed for removal by completely removing whatever device is used to tighten the packing (i.e. the packing or stuffing box nut or gland). There will be various amounts of metal rings and packing components depending upon the type of packing and the model of pump (refer to appropriate illustration or chart). After the removal of all rings and equipment from the stuffing box; thoroughly clean it and inspect for damage, which might keep the new packing from working properly. If the stuffing box is in satisfactory condition, install the new packing as per the appropriate illustration. It is a good idea to lubricate new packing with a light oil prior to installation. Most of the standard packing used in pumps should be tightened with the original equipment-packing wrench while the pump is running under normal operating pressure. After a two or three hour run-in, check the packing for tightness and re-adjust as necessary. Packing should be checked for tightness on a periodic basis, but it is not a good idea to attempt to periodically tighten the packing as part of routine maintenance. This tends to “wear out” the packing prematurely. When the packing leaks in an excessive amount it should be replaced. There is no value in constantly “re-tightening” leaking packing.

If your pump is equipped with optional “spring loaded” packing, there is no adjustment in this equipment during its operational life. The stuffing box nut is initially tightened as much as possible and there is no further adjustment. Note: In all cases the spring goes in the stuffing box before the packing rings.

When using the optional Kevlar or Teflon packing, be sure to rotate the “splits” so that none are “aligned” to insure that the packing holds properly. Normally, this packing is not lubricated and requires less tension on the stuffing box nut during operation.



**CAUTION:** An “airtight” seal is not desirable with this plunger packing. Some slight dripage is desirable during operation. Attempts to tighten packing until it completely “seals off” will result in premature failure from too much friction. The Kevlar & Teflon packing must be allowed to drip a small amount to assure normal life.

- F. **PONY ROD and PONY ROD PACKING:** Kerr Pumps use two pony rod sealing arrangements, models KD-1250, KJ-2250, KM-3250 and KCP-6300 use a screw in seal gland, all other models use a bolt in seal gland, these glands use press in oil seals with snap ring retainers. Some Bolt in gland use adjustable packing arrangements with bolt in or screw in followers to adjust packing. By unscrewing plunger from pony rod a gap may be facilitated to allow the removal of the various sealing arrangements. A special wrench will be needed to remove and replace pony rod to crosshead. (This wrench is available from **Kerr Dealers**) All pony rods have a jam nut to align tighten pony rod to crosshead, care must be exercised in installing new seal on pony rod not to damage it.

## G. DISASSEMBLY OF POWER END



**CAUTION:** Prior to disassembly of any power end, the plunger, pony rod, and pony rod seal housing must be removed.

Expose the crankshaft and connecting rods by removing the pan cover. Connecting rod caps may now be removed and the connecting rod and crosshead should be shoved all the way to the rear (toward the fluid end) to facilitate crankshaft removal out either side as convenient. The connecting rods and crossheads may now be taken out the front cavity exposed by removing the crankshaft. Connecting rods may be removed from the crosshead by loosening the setscrew and driving out the wrist pin from the crosshead. A bronze bushing is used in the rod it may be driven out of the rod and replaced with a new bushing. Reassembly is the reverse of the above outlined sequence with the following considerations for “fits” or tolerance:

- i. General: All Kerr components are machined on modern production machine tools and are of the same specifications and close tolerances you would expect in a modern automobile engine. It must be pointed out that at top speed (350 to 400 RPM) your pump will not even be approaching idle speed for a gasoline engine so “field fits” are possible and practical when making repairs and replacements away from the factory. All procedures outlined below are possible with only hand tools and absolutely no instruments, special tools, or gauges are needed.
- ii. Connecting rod and wrist pin: Proper fit will find the wrist pin turning freely in its bore in the connecting rod, but it should have no “wobble” that is discernable up and down the main axis of the connecting rod. This looseness in the wrist pin fit is the most probable cause of “knocking” which is traceable to the power end of most all pumps. The only solution for loose fitting wrist pins is to discard the connecting rod wrist pin bushing and replace with a new one. If any wear is visible on the wrist pin it should always be replaced.
- iii. Crankshaft End Play and Lateral adjustments: Adjustment of the Taper Roller bearings used in all Kerr Pumps is accomplished by removing or adding shims under the bearing housing. Shims are taken out or added until the crankshaft (without connecting rods) will turn freely, but with no endplay felt when attempting to pull or push the jackshaft end of the crankshaft along its long axis. Some lateral adjustment is possible by removing shims from one side of the crankshaft and adding them to the opposite side. (Note: Lateral adjustment is the “centering” of the crankshaft in the power frame housing.)
- iv. Connecting Rod to Crankshaft fitting: Factory bored connecting rods will normally fit the standard crankshaft journal just by bolting the cap on the rod with the standard rod shims being used. If the caps do require adjustment this is accomplished by removing or adding various thicknesses of rod shims. The standard connecting rod shim used on all Kerr Pumps is 1/32” thick and is comprised of .002” laminates, which can be “pealed “ off separately. Proper fit of the connecting rod will allow the pump crankshaft to be rotated while not allowing in-and-out slack in the connecting rod along its long or main axis. A well-fitted rod will have none of the in-and-out slack, but should be free enough to be moved from side to side on the rod journal. This insures the rod not being too tight. A point of

caution when installing the connecting rod assembly in the pump is to make certain the oil holes in the rod are “UP” and not toward the bottom of the pump. This will result in lubrication failure in these parts and the pump will fail in a short period of time. An additionally important step is to make sure that the rod cap is bolted back on the rod as it came off. The rod and cap carry a “mark” or “number” which allows you to match them back properly. Failure to do this will cause the rod not to fit the journal for which it was made.

- H. Power End/Fluid End Connection: A common misconception is that there is some form of fluid seal between the power end and the fluid end. This is false. The fluid end is merely bolted to the power frame. It can be removed by breaking the plunger connection, backing off the packing nut or gland, removing the various fluid end bolts, and sliding the entire fluid end off the power frame. Corrosion may tend to seize the two components together making their separation difficult in some isolated cases. On models KP-3300, KT-3350/KT-3400 and R335/R340 the bolted in stuffing box assemblies must be removed prior to removal of the entire fluid end. They are held in place by four studs each. On all other units the stuffing boxes can be left intact. On the remaining pumps (with the exception KD-1250B, KJ-2250B, KM-3250B, and KCP-6300) the stuffing boxes are held in place in the fluid end by a friction or “press” fit. They should be removed with a hydraulic press if possible. These press-in type stuffing boxes carry a gasket and/or an o-ring to insure a good seal. The boxes on the KD-1250B, KJ-2250B, KM-3250B, and KCP-6300 are screw-in type and carry only a copper gasket.



BUCKHORN  
PUMPS, INC.



## TECHNICAL DATA SHEET

T.D.S. NO.

4.2

PCN: \_\_\_\_\_

Supercedes PCN: \_\_\_\_\_

Date

03-10-06

### SHORT TERM STORAGE PREPARATION PROCEDURE

#### 1.0 SCOPE

This procedure applies to Kerr Pumps ONLY. Storage procedures for any other unit components or accessories (gear reducers, engines, etc.) are to be prepared to the specific manufacture's recommendations.

- 1.1 Short-term storage is defined as storage and/or transient time less than six (6) months in an environment defined in Paragraph 2. If storage exceeding six months is expected, the Long Term Pump Storage Preparation Procedure should be followed.
- 1.2 Kerr Pumps will only prepared for short term storage if so specified in the purchaser or customer order control document.

#### 2.0 STORAGE ENVIRONMENT

A minimal environmental condition, to be met by the customer or purchaser, is a closed shelter to eliminate effects of sun, wind, sand or other debris. Large temperature and humidity changes should be avoided to prevent coating deterioration or contamination by moisture.

#### 3.0 PRESERVATIVE PRODUCT

- 3.1 The specified rust preservative will protect the internal power end parts from corrosion due to atmospheric moisture, and may be left in the pump when filled with appropriate lubricant and placed into service. The elevated temperature of service will cause rapid depletion of the preventative protection.
- 3.2 The following rust preventative products or their equivalents are recommended for use in Kerr Pumps and usually available in 5 gallon, 55 gallon containers:
  - CITGO: RUST-O-LINE OIL 10
  - SHELL: ENSIS OIL N

#### 4.0 PROCEDURE

- 4.1 Preparation from; factory testing, inventory, or a distributor rebuild facility.
  - Drain any oil that may be in the power end, and then fill the complete power end cavity with the specified rust preventative. After 15 to 20 minutes, drain the rust preventative back into its storage drum for future use.
  - Remove and clean oil level gages, pressure gages and breather caps. Replace with pipe plugs in threaded openings. All breathers shall be replaced with airtight seals, plugs or gasketed plates. No venting is recommended as it may allow moist air in.

BUCKHORN  
PUMPS, INC.

## TECHNICAL DATA SHEET

T.D.S. NO.

4.2

PCN: \_\_\_\_\_

Supercedes PCN: \_\_\_\_\_

Date 03-10-06

- 4.1.1 Remove the wiper box seals and cap/plug the seal opening.
  - 4.1.2 Clean the pump outer surfaces prior to painting.
  - 4.1.3 If painting is required mask crank and lubricator shaft surfaces and keyways. If painting does not apply, go to Para. 4.1.8.
  - 4.1.4 Paint as specified by the customer order or as required.
  - 4.1.5 Apply a thin layer of grease to the exposed oil seal lips.
  - 4.1.6 Apply a thin layer of heavy rust preventative to the exposed crank and lubricator shaft surfaces and keyways.
  - 4.1.7 Wrap the exposed crank and lubricator shafts with waxed tape.
  - 4.1.8 Carefully wrap the following parts prior to placing them into polyurethane bags. Oil level gages, lube pressure gages, and breather caps.
  - 4.1.9 Finish box, crate and mark the parts from Para. 4.1.2 after final inspection (see Para. 4.2.2).
- 4.2 Shipping/Receiving (New Pumps Only)
- 4.2.1 All pumps and accessories (as applicable) will be final inspected by Kerr Pump personnel prior to shipping. Any witnessed or third party inspection will be signed-off by the purchaser or customer representative prior to final crating and shipment.
  - 4.2.2 Export crating will be performed by either an approved Kerr Pump source or as specified by the purchaser or customer. Any third party inspection will be coordinated with the source.
  - 4.2.3 Upon receipt of the shipment, the purchaser or customer is responsible for inspection and repair of damaged coatings at the expense of the shipper.

## 5.0 WARRANTY/START-UP

- 5.1 Pumps prepared per the above procedure qualify for the "Standard Terms & Conditions" in force on the date of shipment.
- 5.2 If the pump storage period is less than 6 months, follow the Short Term Pump Preparation Procedure.
- 5.3 Prior to start-up:
  - 5.3.1 Remove all storage caps, plugs, and covers.
  - 5.3.2 Replace any damaged or cracked O-rings or gaskets.
  - 5.3.3 Inspect power end shaft oil seals and replace if cracked, split or damaged.
  - 5.3.4 Install crankcase drain plug, lubrication level site glass and breather cap.
  - 5.3.5 Install, if applicable, any oil pressure and/or temperature gage.
  - 5.3.6 Check the connection of the plunger and pony rod to the crosshead prior to, and after, initial run-in of the pump.
  - 5.3.7 Fill the crankcase to the proper level with the specified lubricant.

BUCKHORN  
PUMPS, INC.



**TITLE: LONG TERM STORAGE PREPARATION PROCEDURE****1.0 SCOPE**

This procedure applies to Kerr Pumps ONLY. Storage procedures for any other unit components or accessories (gear reducers, engines, etc.) are to be prepared to the specific manufacture's recommendations.

**1.1** Long-term storage is defined as storage and/or transient time exceeding six (6) months in an environment defined in Paragraph 2. If storage for less than six months is expected, the Short Term Pump Storage Preparation Procedure should be followed.

**1.2** Kerr Pumps will only prepare for short term storage if so specified in the purchaser or customer order control document.

**2.0 STORAGE ENVIRONMENT**

A minimal environmental condition, to be met by the customer or purchaser, is a closed shelter to eliminate effects of sun, wind, sand or other debris. Large temperature and humidity changes should be avoided to prevent preventative deterioration or contamination by moisture.

**3.0 RUST PREVENTATIVE PRODUCT**

**3.1** The recommended rust preservative should protect the internal power end parts from corrosion due to atmospheric moisture, and may be left in the pump when filled with appropriate lubricant and placed into service. The elevated temperature of service will cause rapid depletion of the preventative protection.

**3.2** The following rust preventative products or their equivalents are recommended for use in Kerr Pumps and usually available in 5 gallon, 55 gallon containers:

CITGO: RUST-O-LINE OIL 10

SHELL: ENSIS OIL N

**4.0 PROCEDURE**

**4.1** Preparation from; factory testing, inventory, or a distributor rebuild facility.

**4.1.1** Drain any oil that may be in the power end and then fill the complete power end cavity with the specified rust preventative. After 15 to 20 minutes, drain the rust preventative back into its storage drum for future use.

**4.1.2** Remove all plungers, pony rods (if applicable), baffle discs, packing and junk rings.

**4.1.3** Remove and clean oil level gages, pressure gages and breather caps. Replace with pipe plugs in threaded openings.

## TECHNICAL DATA SHEET

T.D.S. NO. 4.3

PCN: \_\_\_\_\_

Supercedes PCN: \_\_\_\_\_

Date 03-10-06

- 4.1.4 All breathers shall be replaced with airtight seals, plugs or gasketed plates. No venting is recommended as it may allow moist air in.
  - 4.1.5 Remove the wiper box seals and cap/plug the seal opening.
  - 4.1.6 Clean the pump outer surfaces prior to painting.
  - 4.1.7 If painting is required mask crank and lubricator shaft surfaces and keyways. If painting does not apply, go to Para. 4.1.9.
  - 4.1.8 Paint as specified by the customer order or as required.
  - 4.1.9 Apply a thin layer of grease to the exposed oil seal lips.
  - 4.1.10 Apply a thin layer of heavy rust preventative to the exposed crank and lubricator shaft surfaces and keyways.
  - 4.1.11 Wrap the exposed crank and lubricator shafts with waxed tape.
  - 4.1.12 Carefully wrap the following parts prior to placing them into polyurethane bags. Oil level gages, lube pressure gages, and breather caps.
  - 4.1.13 Finish box, crate and mark the parts from Para. 4.1.10 after final inspection (see Para. 4.2.2).
- 4.2 Shipping/Receiving (New Pumps Only)
- 4.2.1 All pumps and accessories (as applicable) will be final inspected by Kerr Pump personnel prior to shipping. Any witnessed or third party inspection will be signed-off by the purchaser or customer representative prior to final crating and shipment.
  - 4.2.2 Export crating will be performed by either an approved Kerr Pump source or as specified by the purchaser or customer. Any third party inspection will be coordinated with the source.
  - 4.2.3 Upon receipt of the shipment, the purchaser or customer is responsible for inspection and repair of damaged coatings at the expense of the shipper.

## 5.0 WARRANTY / START-UP

- 5.1 Pumps prepared per the above procedure qualify for the "Standard Terms & Conditions" in force on the date of shipment.
- 5.2 If the pump storage period will exceed 6 months, follow the Long-Term Pump Preparation Procedure.
- 5.3 Prior to start-up:
  - 5.3.1 Remove all storage caps, plugs, and covers.
  - 5.3.2 Install the packing, junk rings, plungers, pony rods (if applicable), baffle discs, and wiper box seals. Replace any damaged or cracked O-rings or gaskets.
  - 5.3.3 Inspect power end shaft oil seals and replace if cracked, split or damaged.
  - 5.3.4 Install crankcase drain plug, lubrication level site glass and breather cap.
  - 5.3.5 Install, if applicable, any oil pressure and/or temperature gage.
  - 5.3.6 Check the connection of the plunger and pony rod to the crosshead prior to, and after, initial run-in of the pump.
  - 5.3.7 Fill the crankcase to the proper level with the specified lubricant.

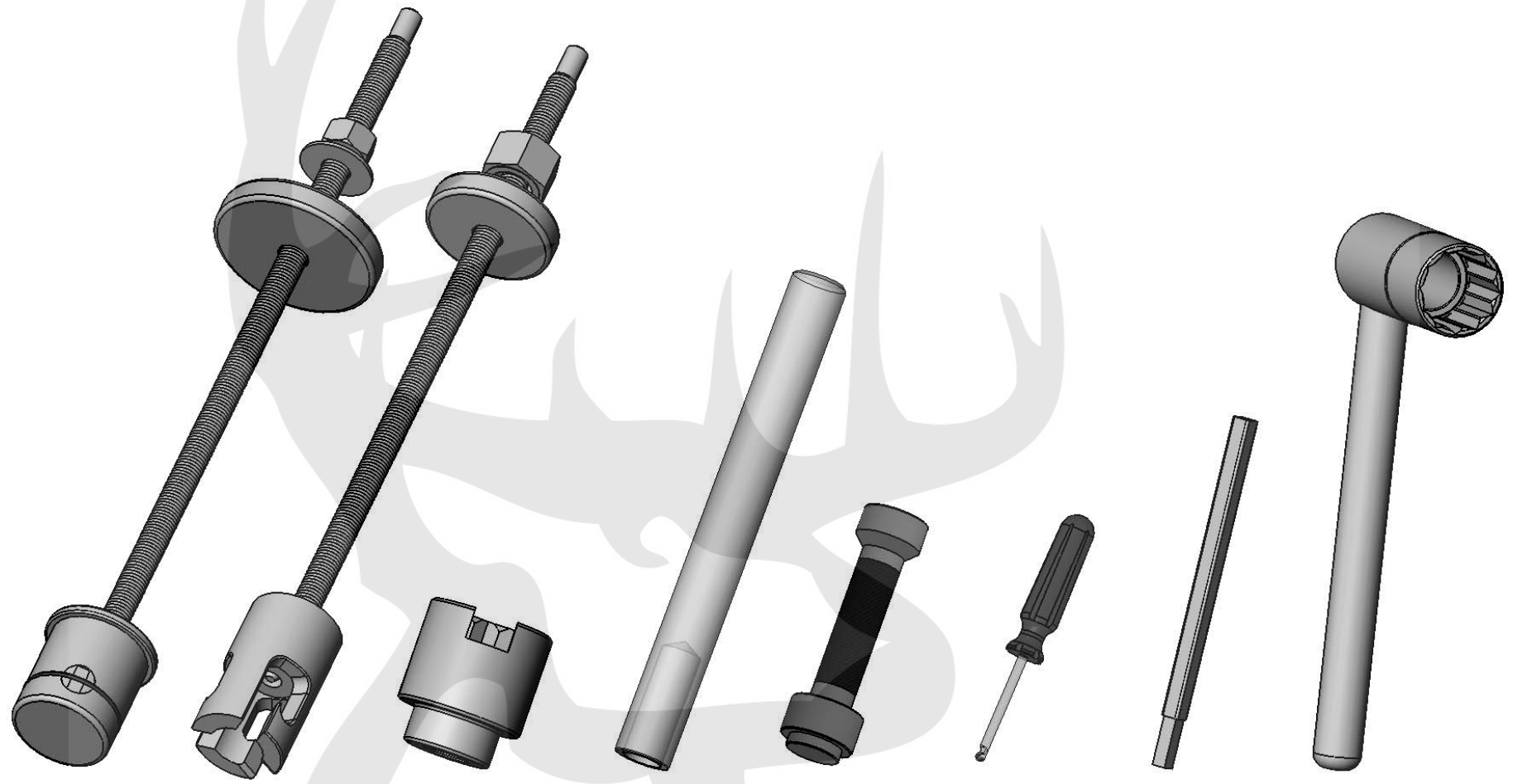

KA-68M  
WING-  
GUIDED  
SEAT  
TRI-PIN  
TYPE  
PULLER  
ASS'Y

KA-555  
DISC SEAT  
"J" TYPE  
PULLER  
ASS'Y

KA-550  
CAGE  
WRENCH

KA-306  
VALVE  
SEAT  
SEATING  
TOOL

KA-276  
PONY ROD  
SEAL TOOL

AP-77T  
VALVE  
INSERT  
TOOL

AP-425  
STUFFING  
BOX NUT  
WRENCH

KA-277  
PONY  
ROD  
WRENCH

**SPECIAL TOOLS  
FOR KA-3500, KT-3350, & KT-3400**

BUCKHORN  
PUMPS, INC.

## How To Put Inserts In Valves Using Kerr Valve Insert Tool



1) Push Valve Insert over valve legs. Hint: (Insert will be more pliable if heated first-- warm to the touch not hot).



2) Put Tool between valve and valve insert with groove against valve.



3) Holding Valve insert down with thumb.



4) While holding valve down with thumb, rotate around valve with tool. (Similar to mounting a tire on a rim).



5) Continue rotating around valve with tool until insert is completely in groove.



# Wing Guided Valve Changing Instructions



**1.) Remove the nuts/cap screws from the top cover.**



**2.A) Remove the top cover and discharge spring.  
2.B) Inspect the o-ring for damage.**

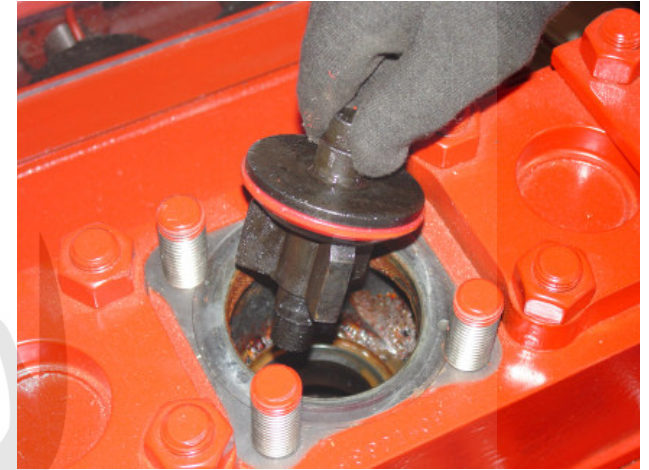

**3.) Remove the discharge valve.**



**4.A) Remove the end cover cap and suction spring.  
4.B) Inspect the valve spring for damage.**



**5.) Remove the suction valve.**



**6.) Insert the tri-pin puller head, all pins retracted, into the discharge seat.**



## Wing Guided Valve Changing Instructions (...continued)

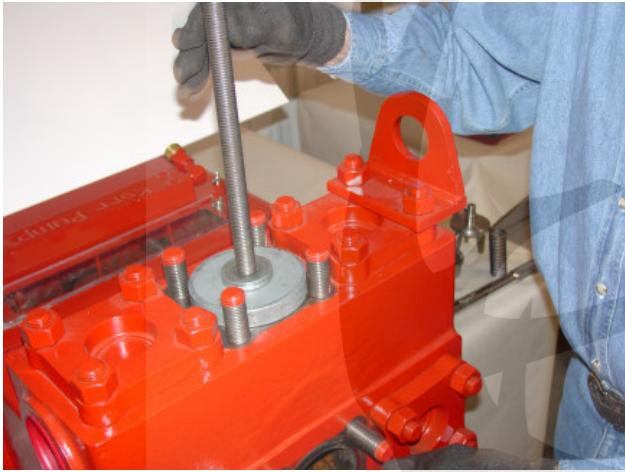

7.) Slide puller plate, spacer and washers down the puller rod.



8.) Turn the puller rod until the pins are fully extended.

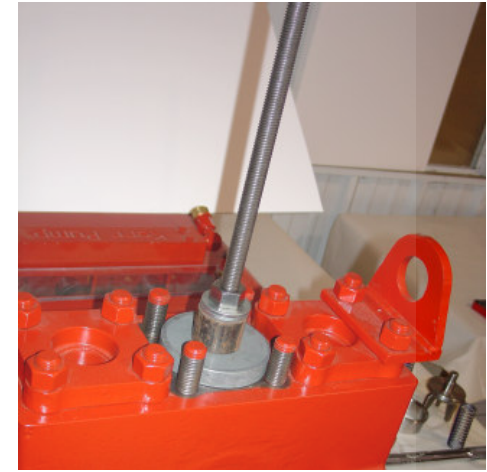

9.) Lifting the puller rod, turn the nut until firmly in contact with the washers.



10.) Holding the top of the puller rod in place, tighten the nut until the seat releases.



11.) Remove the puller assembly with seat attached.



12.) Loosen the puller rod to retract the pins and remove the seat.

» Repeat steps 6 thru 12 for suction valve.

## Wing Guided Valve Changing Instructions (...continued)



**13.) Install the suction seat and valve. Drive in firmly using bar and hammer.**



**14.) Install the discharge seat and valve. Drive in firmly using bar and hammer.**



**15.) Install the suction spring.**

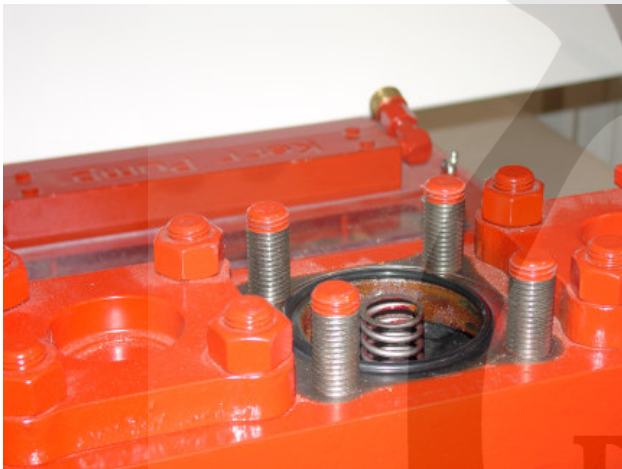

**16.) Install the discharge spring.**



**17.) Tighten all bolts/nuts to specified torque from chart.**

**BUCKHORN  
PUMPS, INC.**



## Disc Valve Changing Instructions



1.) Remove the nuts/cap screws from the top and end covers.



2.) Remove the top and end covers.



3.) Unthread the discharge valve cap screw and remove with retainer, spring, disc and sleeve.



4.) Insert the "J" puller head into and through the discharge seat.



5.) Slide puller plate spacer and washers down the puller rod.

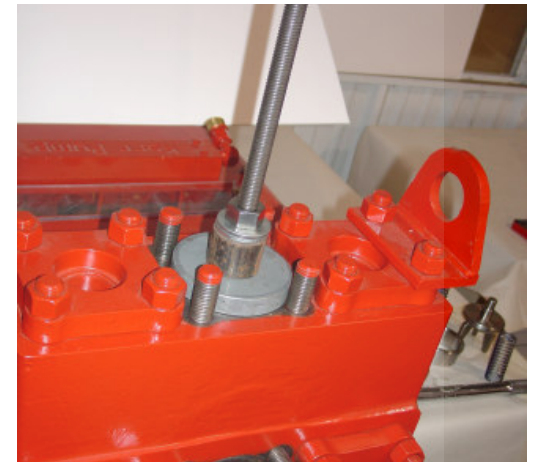

6.) Rotate the puller rod 1/4 turn clockwise and lift it. Thread the nut by hand down to the washers

BUCKHORN  
PUMPS, INC.

## Disc Valve Changing Instructions (...continued)

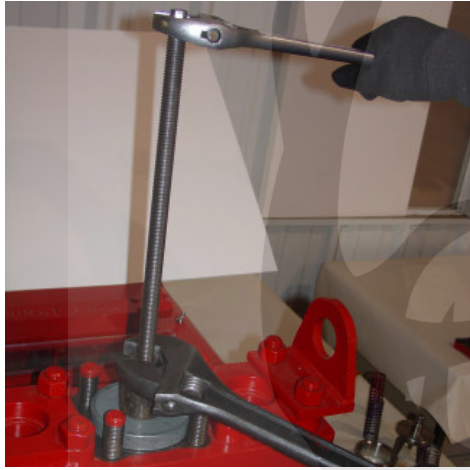

7.) Holding the top of the puller rod in place, tighten the nut until the seat releases.

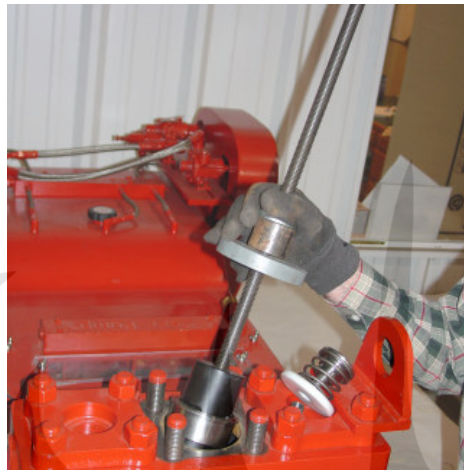

8.) Remove the puller assembly with seat attached.



9.) Remove the seat from the puller head and remove the remaining discharge seats

» Repeat steps 4 thru 9 for suction valve.



10.) Install seat only in the lower suction location and with an old/used disc on top of the new seat, drive in firmly with a hollow bar.



11.) Install the disc sleeve spring, retainer and cap screw. Tighten to the specified torque.



12.) Install covers with seals, nut/cap screws and tighten to specified torque from chart.

### WARNING

Do NOT use a solid bar it will overload and deflect the center pod

» Repeat steps 10 thru 12 for upper discharge location.



Kerr KA-3500 Plunger Pump

BUCKHORN  
PUMPS, INC.



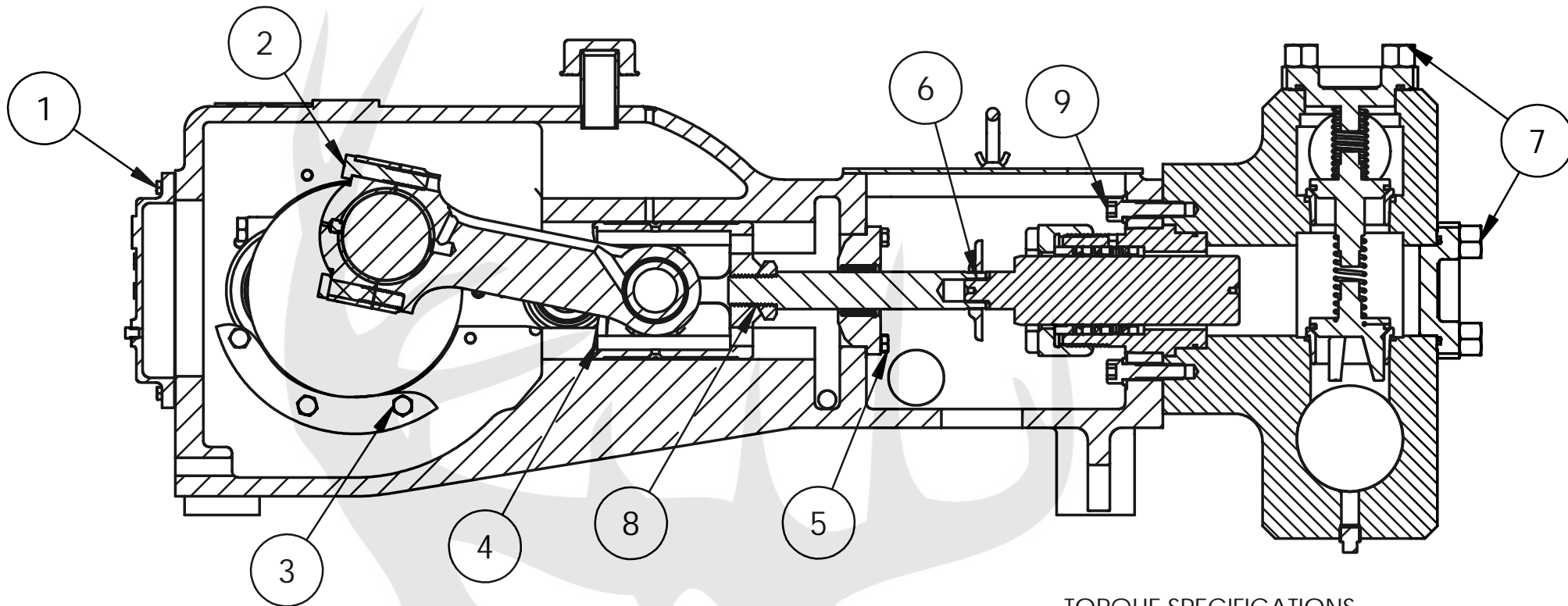

### TORQUE SPECIFICATIONS

REFERENCE	DESCRIPTION	TORQUE
1	PAN COVER CAPSCREW	21 ft-lb (28 Nm)
2	CONNECTING ROD CAPSCREW	160 ft-lb (217 Nm)
3	BEARING HOUSING CAPSCREW	75 ft-lb (102 Nm)
4	WRIST PIN SET SCREW AND JAM NUT	30 ft-lb (41 Nm)
5	PONY ROD PACKING GLAND CAPSCREW	50 ft-lb (68 Nm)
6	PLUNGER TO PONY ROD	500 ft-lb (678 Nm)
7	COVER CAP STUD NUT	200 ft-lb (271 Nm)
8	PONY ROD TO CROSSHEAD	1000 ft-lb (1356 Nm)
9	CAPSCREW FLUID END/CASE	200 ft-lb (271 Nm)

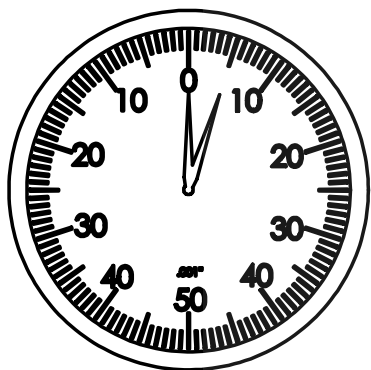

.000" - .005"  
SHAFT END PLAY

WHEN ADJUSTING THE ENDPLAY OF THE TAPERED ROLLER BEARINGS USED ON THE CRANKSHAFT, DIAL INDICATORS AND SHIMS MUST BE PROPERLY USED. INCORRECT BEARING ADJUSTMENT MAY RESULT IN EXCESSIVE NOISE, TEMPERATURE, AND REDUCED BEARING LIFE. Kerr Pumps RECOMMENDS BETWEEN .000" - .005" OF INTERNAL AXIAL CLEARANCE (END PLAY) WHEN ASSEMBLED. FINAL ADJUSTMENT MUST BE MADE USING A DIAL INDICATOR.

INSURE THE CONNECTING RODS ARE DISCONNECTED TO ALLOW FREE CRANKSHAFT MOTION.

### KA-3500 SPECIFICATIONS

NOTE: WHEN USING LUBRICANTS  
REDUCE TORQUE AS FOLLOWS:

LUBRICANT	PERCENTAGE OF TORQUE REDUCTION REQUIRED
WHITE LEAD	REDUCE TORQUE 25%
GRAPHITE	REDUCE TORQUE 30%
OIL	REDUCE TORQUE 40%
GREASE	REDUCE TORQUE 40%
ANTI - SEIZE COMPOUND	REDUCE TORQUE 45%

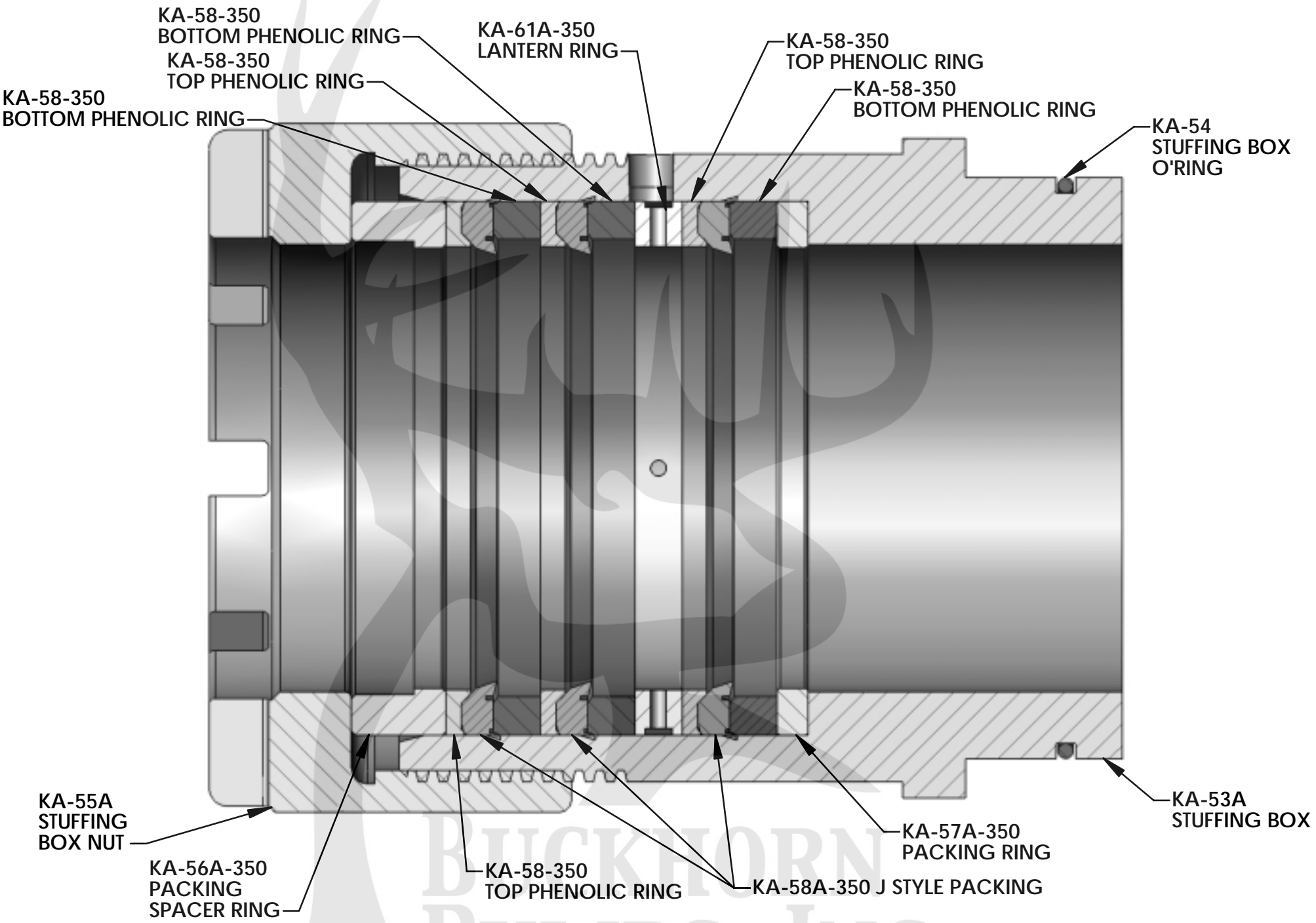

**KA-3500 "A" BOX  
PACKING ARRANGEMENT (FOR 3.500" PLUNGERS)**

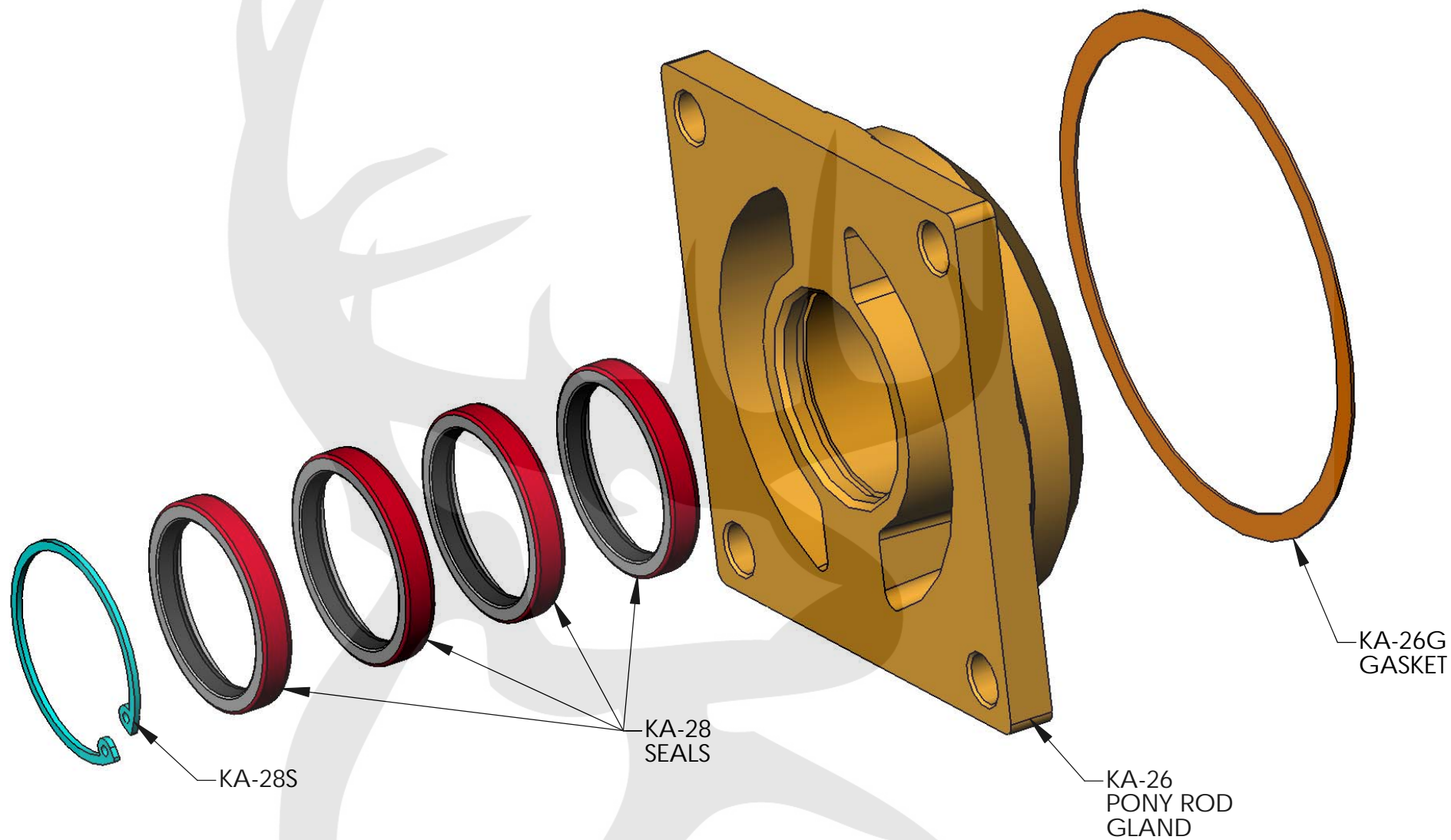

KA-26-A  
PONY ROD  
PACKING GLAND  
ASSEMBLY

BUCKLE UP  
PUMPS, INC.

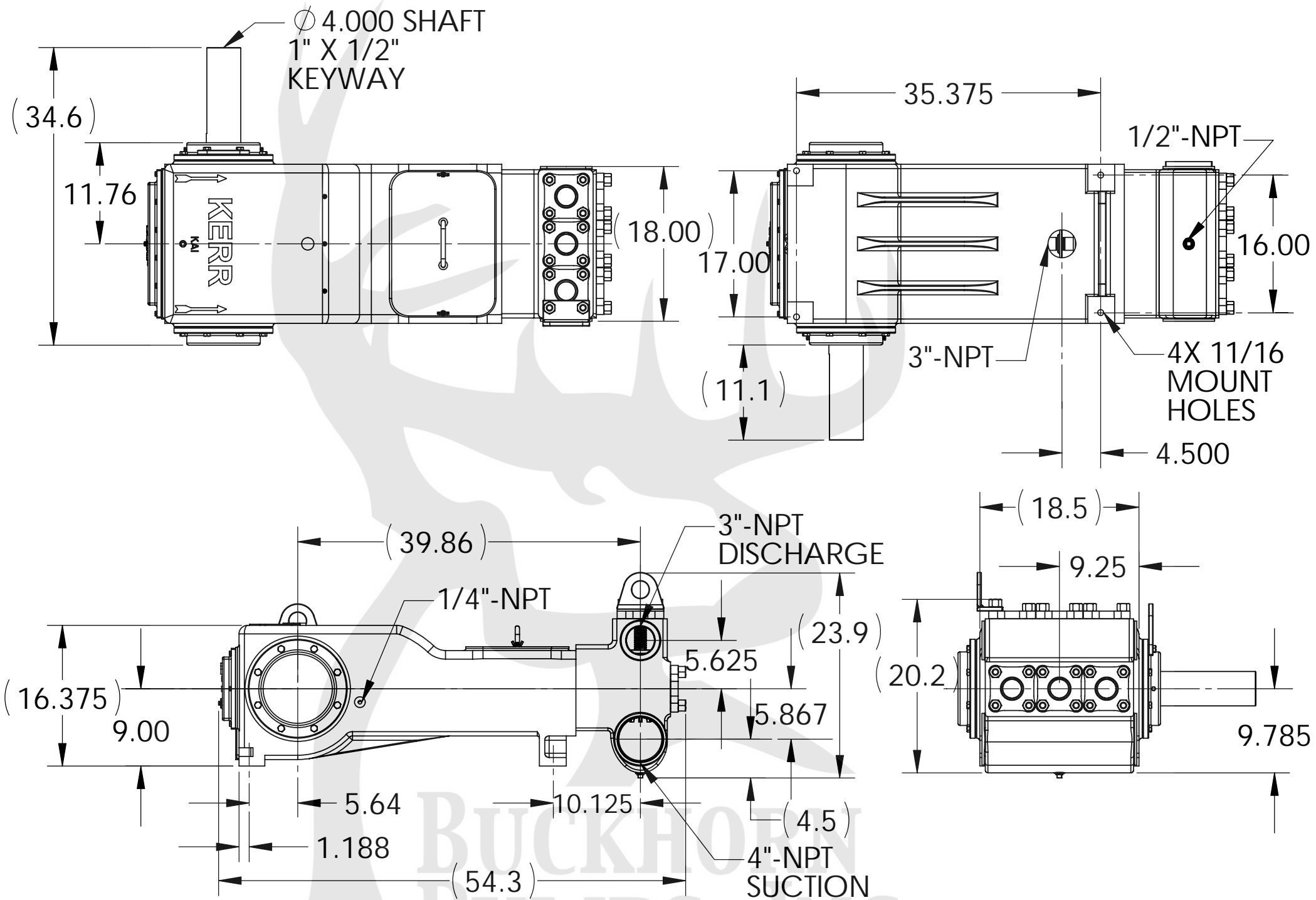

**GENERAL DIMENSIONS FOR KA-3500**

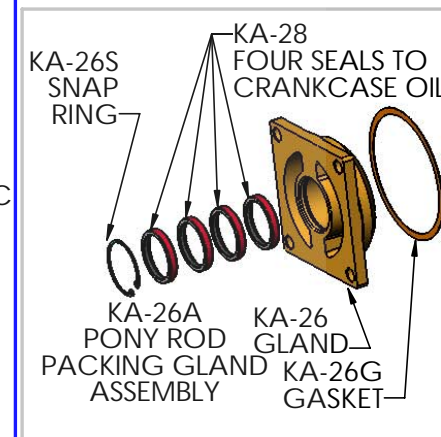
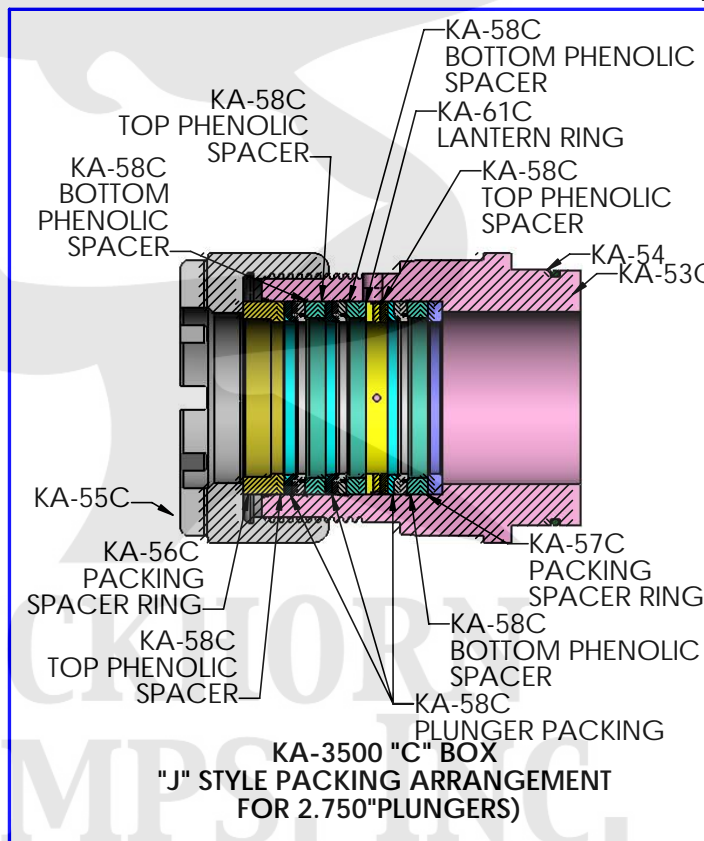
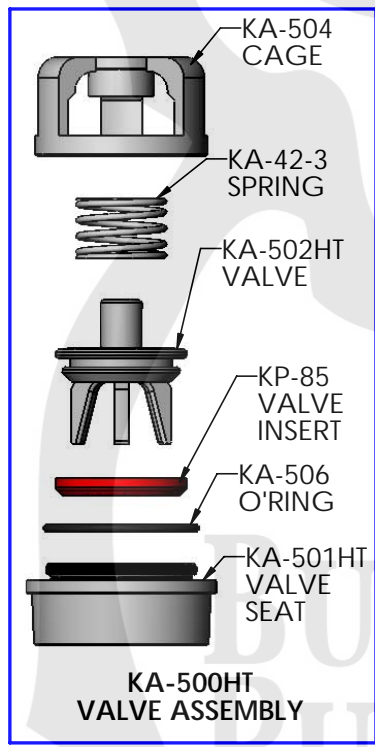
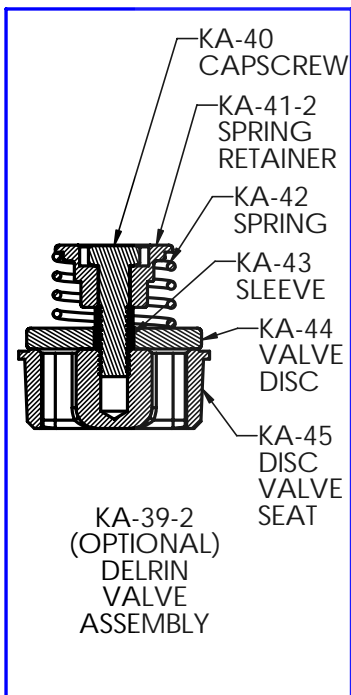
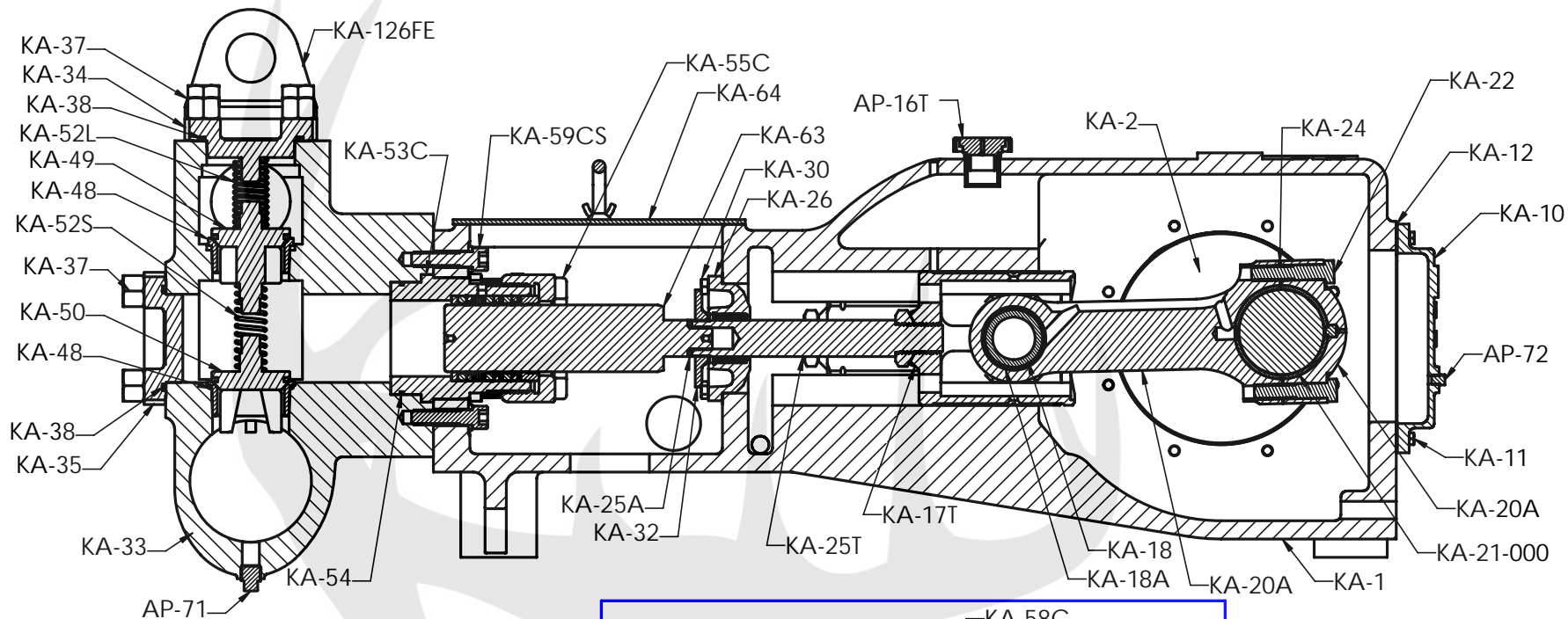

PUMP & GEAR REDUCER LUBRICATION	GEAR OIL
BELOW 30 °F	40W
30-50 °F	50W
ABOVE 50 °F	90W

**KA-3500**

## Kerr KA-3500 Plunger Type Pump

Part Number	Description	# Req
KA-1	Pump Case	1
KA-2	Crankshaft-Heat Treated	1
KA-2S	Crankshaft-Heat Treated (Steel)	1
KA-2TP	Crankshaft, For Lube System TP	1
KA-3	Crankshaft Oil Seal	1
KA-4	Bearing Housing (Blind Side)	1
KA-5	Bearing Housing (Shaft Side)	1
KA-6	Bearing Housing Capscrews	14
KA-6B	Bearing Housing Capscrews 2	3
KA-7	Bearing Housing Gaskets	2
KA-8-005	Main Bearing Adjusting Shims .005	
KA-8-010	Main Bearing Adjusting Shims .010	
KA-8-015	Main Bearing Adjusting Shims .015	
KA-9	Main Bearings	2
KA-10	Pan Cover	1
KA-11	Pan Cover Capscrews	14
KA-12	Pan Cover Gasket	1
AP-16	Breather Cap (Oil Filler)	1
AP-16T	Breather Cap (Oil Filler) Threaded Style	1
KA-17	Crosshead	3
KA-17T	Crosshead Tapered	3
KA-18	Wrist Pin	3
KA-18A	Wrist Pin Bushing	3
KA-19	Wrist Pin Set Screws & Nut	3
KA-20	Connecting Rod Only (No Inserts - Requires inserts both ends)	3
KA-20A	Connecting Rod (Inserted Both Ends)	3
KA-21-000	Connecting Rod Insert Bushing (Std)	3
KA-21-015	Connecting Rod Insert Bushing (.015)	3
KA-21-030	Connecting Rod Insert Bushing (.030)	3
KA-21-000HRL	Connecting Rod Insert Bushing (HRL)	3
KA-22	Connecting Rod Capscrew	6
KA-24	Connecting Rod Shims (Laminated)	12Laminate
KA-25	Pony Rod with Jam Nut Installed	3
KA-25A	Pony Rod Washer	3
KA-25T	Pony Rod with Jam Nut (Tapered)	3
KA-26	Pony Rod Seal Gland Snap Ring Type	3
KA-26A	Pony Rod Gland Assembly (Pony Rod Gland, Snap Ring, Seals)	3
KA-26F	Pony Rod Packing Gland Follower Type	3
KA-26G	Pony Rod Gland Gasket	3
KA-26S	Pony Rod Gland Snap Ring	3

BUCKHORN  
PUMPS, INC.



## Kerr KA-3500 Plunger Type Pump

Part Number	Description	# Req
KA-27	Pony Rod Packing Gland Follower Screw Type	3
KA-28	Pony Rod Seal (4 Seals per Set)	3 sets
KA-28F	Pony Rod Packing Set	3
KA-30	Pony Rod Gland Capscrews SS	12
KA-32	Pony Rod Splash Guard	3
KA-33S	Fluid End Vessel Only (Cast Steel)	1
KA-33AB	Fluid End Vessel Only (ALBZ)	1
KA-33DM	Fluid End Vessel Only (Ductile)	1
KA-33DX	Fluid End Vessel Only (Duplex Stainless Steel)	1
KA-33SS	Fluid End Vessel Only (Cast Stainless Steel)	1
KA-33FS	Fluid End Vessel Only (Forged Steel)	1
KA-33FSS	Fluid End Vessel Only (Forged Stainless Steel)	1
KA-33-375AB	Fluid End Vessel Only (ALBZ)	1
KA-33-375DX	Fluid End Vessel Only (Duplex Stainless Steel)	1
KA-33-375S	Fluid End Vessel Only (Cast Steel)	1
KA-33-375SS	Fluid End Vessel Only (Cast Stainless Steel)	1
KA-34AB	Top Cover Cap (ALBZ)	3
KA-34D	Top Cover Cap (Ductile)	3
KA-34DX	Top Cover Cap (Duplex Stainless Steel)	3
KA-34S	Top Cover Cap (Steel)	3
KA-34SS	Top Cover Cap (Stainless Steel)	3
KA-35AB	End Cover Cap (ALBZ)	3
KA-35D	End Cover Cap (Ductile)	3
KA-35DX	End Cover Cap (Duplex Stainless Steel)	3
KA-35S	End Cover Cap (Steel)	3
KA-35SS	End Cover Cap (Stainless Steel)	3
KA-35-375AB	End Cover Cap (ALBZ)	3
KA-35-375DX	End Cover Cap (Duplex Stainless Steel)	3
KA-35-375S	End Cover Cap (Steel)	3
KA-35-375SS	End Cover Cap (Stainless Steel)	3
KA-36	Cover Cap Stud	24
KA-36B	Cover Cap Bracket Stud	2
KA-37	Cover Cap Stud Nut	24
KA-38A	Cover Cap O' Ring (Aflas)	6
KA-38N	Cover Cap O' Ring (Nitrile)	6
KA-38-155	Cover Cap O' Ring	6
KA-39AB	Delrin Disc Type Valve Complete with ALBZ Seat	6
KA-39M	Delrin Disc Type Valve Complete with Monel Seat	6
KA-39DX	Delrin Disc Type Valve Complete with Duplex Stainless Seat	6
KA-39SSM	SS Disc Valve Complete with Monel Seat	6

HORN  
PUMPS, INC.

## Kerr KA-3500 Plunger Type Pump

Part Number	Description	# Req
KA-39SSSS	SS Disc Valve Complete with Stainless Steel Seat	6
KA-39TM	Titanium Disc Valve Complete with Monel Seat	6
KA-40	Capscrew Disc Valve	1
KA-41-2	Retainer Dual Spring Disc Valve	1 Per Valv
KA-42	Spring, Valve	6
KA-42-2	Spring, Disc Valve, Outer	6
KA-42-3	Spring, Disc Valve, Inner	6
KA-43	Sleeve Disc Valve	1
KA-44	Delrin Valve Disc	1
KA-44SS	Stainless Steel Valve Disc	1
KA-44T	Titanium Valve Disc	1
KA-45AB	Valve Seat ALBZ Disc Type	1
KA-45M	Valve Seat Monel Disc Type	1
KA-45SS	Valve Seat Stainless Steel Disc Type	1
KA-46	Discharge Valve (ALBZ, Wing-Guided)	3
KA-47	Suction Valve (ALBZ, Wing-Guided)	3
KA-48	Valve Seat (ALBZ, Wing-Guided)	6
KA-49	Discharge Valve (Monel,Wing-Guided)	3
KA-49SS	Discharge Valve (Stainless Steel, Wing-Guided)	3
KA-50	Suction Valve (Monel, Wing-Guided)	3
KA-50SS	Suction Valve (Stainless Steel, Wing-Guided)	3
KA-51	Valve Seat (Monel, Wing-Guided)	3
KA-51SS	Valve Seat (Stainless Steel, Wing-Guided)	3
KA-52L	Valve Spring (Discharge) (Long)	3
KA-52S	Valve Spring (Suction) (Short)	3
KA-53A	Stuffing Box (ALBZ)A Box	3
KA-53A-DX	Stuffing Box (Duplex Stainless) A Box	3
KA-53A-S	Stuffing Box (Steel) A Box	3
KA-53A-SS	Stuffing Box (Stainless Steel) A Box	3
KA-53A-375AB	Stuffing Box (ALBZ)A Box	3
KA-53A-375DX	Stuffing Box (Duplex Stainless) A Box	3
KA-53A-375S	Stuffing Box (Steel) A Box	3
KA-53A-375SS	Stuffing Box (Stainless Steel) A Box	3
KA-53CAB	Stuffing Box (ALBZ) C Box	3
KA-53CDX	Stuffing Box (Duplex Stainless) C Box	3
KA-53CS	Stuffing Box (Steel) C Box	3
KA-53CSS	Stuffing Box (Stainless Steel) C Box	3
KA-54RA	Stuffing Box O'Ring (Aflas)	3
KA-54RN	Stuffing Box O'Ring (Nitrile)	3
KA-55A-AB	Stuffing Box Nut (ALBZ)	3

BUCKHORN  
PUMPS, INC.

## Kerr KA-3500 Plunger Type Pump

Part Number	Description	# Req
KA-55A-S	Stuffing Box Nut (Steel)	3
KA-55A-DX	Stuffing Box Nut (Duplex Stainless)	3
KA-55A-SS	Stuffing Box Nut (Stainless Steel)	3
KA-55A-375AB	Stuffing Box Nut (ALBZ)	3
KA-55A-375DX	Stuffing Box Nut (Duplex Stainless)	3
KA-55A-375S	Stuffing Box Nut (Steel)	3
KA-55A-375SS	Stuffing Box Nut (Stainless Steel)	3
KA-55AL	Packing Nut Lock A Box	2
KA-55C-AB	Stuffing Box Nut (ALBZ)	3
KA-55C-DX	Stuffing Box Nut (Duplex Stainless)	3
KA-55C-S	Stuffing Box Nut (Steel)	3
KA-55C-SS	Stuffing Box Nut (Stainless Steel)	3
KA-55CL	Packing Nut Lock C Box	2
KA-56A-300AB	Stuffing Box Spacer Ring (ALBZ) A Box 3	3
KA-56A-325AB	Stuffing Box Spacer Ring (ALBZ) A Box 3.25	3
KA-56A-350AB	Stuffing Box Spacer Ring (ALBZ) A Box 3.50	3
KA-56A-375AB	Stuffing Box Spacer Ring (ALBZ) A Box 3.75	3
KA-56A-300DX	Stuffing Box Spacer Ring (Duplex Stainless) A Box 3	3
KA-56A-325DX	Stuffing Box Spacer Ring (Duplex Stainless) A Box 3.25	3
KA-56A-350DX	Stuffing Box Spacer Ring (Duplex Stainless) A Box 3.50	3
KA-56A-375DX	Stuffing Box Spacer Ring (Duplex Stainless) A Box 3.75	3
KA-56A-300S	Stuffing Box Spacer Ring (Steel)A Box 3	3
KA-56A-325S	Stuffing Box Spacer Ring (Steel)A Box 3.25	3
KA-56A-350S	Stuffing Box Spacer Ring (Steel)A Box 3.50	3
KA-56A-375S	Stuffing Box Spacer Ring (Steel)A Box 3.75	3
KA-56A-300SS	Stuffing Box Spacer Ring (Stainless Steel)A Box 3	3
KA-56A-325SS	Stuffing Box Spacer Ring (Stainless Steel)A Box 3.25	3
KA-56A-350SS	Stuffing Box Spacer Ring (Stainless Steel)A Box 3.50	3
KA-56A-375SS	Stuffing Box Spacer Ring (Stainless Steel)A Box 3.75	3
KA-56C-200AB	Stuffing Box Spacer Ring (ALBZ) C Box 2	3
KA-56C-225AB	Stuffing Box Spacer Ring (ALBZ) C Box 2.25	3
KA-56C-250AB	Stuffing Box Spacer Ring (ALBZ)C Box 2.50	3
KA-56C-275AB	Stuffing Box Spacer Ring (ALBZ)C Box 2.75	3
KA-56C-300AB	Stuffing Box Spacer Ring (ALBZ)C Box 3	3
KA-56C-200DX	Stuffing Box Spacer Ring (Duplex Stainless) C Box 2	3
KA-56C-225DX	Stuffing Box Spacer Ring (Duplex Stainless) C Box 2-1/4	3
KA-56C-250DX	Stuffing Box Spacer Ring (Duplex Stainless) C Box 2-1/2	3
KA-56C-275DX	Stuffing Box Spacer Ring (Duplex Stainless) C Box 2-3/4	3
KA-56C-300DX	Stuffing Box Spacer Ring (Duplex Stainless) C Box 3	3
KA-56C-200S	Stuffing Box Spacer Ring (Steel)C Box 2	3

KERR  
PUMPS, INC.

## Kerr KA-3500 Plunger Type Pump

Part Number	Description	# Req
KA-56C-225S	Stuffing Box Spacer Ring (Steel) C Box 2.25	3
KA-56C-250S	Stuffing Box Spacer Ring (Steel)C Box 2.50	3
KA-56C-275S	Stuffing Box Spacer Ring (Steel)C Box 2.75	3
KA-56C-300S	Stuffing Box Spacer Ring (Steel)C Box 3	3
KA-56C-200SS	Stuffing Box Spacer Ring (Stainless Steel)C Box 2	3
KA-56C-225SS	Stuffing Box Spacer Ring (Stainless Steel)C Box 2.25	3
KA-56C-250SS	Stuffing Box Spacer Ring (Stainless Steel)C Box 2.50	3
KA-56C-275SS	Stuffing Box Spacer Ring (Stainless Steel)C Box 2.75	3
KA-56C-300SS	Stuffing Box Spacer Ring (Stainless Steel)C Box 3	3
KA-57A-300AB	Stuffing Box Packing Ring (ALBZ)A Box 3	3
KA-57A-325AB	Stuffing Box Packing Ring (ALBZ)A Box 3.25	3
KA-57A-350AB	Stuffing Box Packing Ring (ALBZ)A Box 3.50	3
KA-57A-375AB	Stuffing Box Packing Ring (ALBZ)A Box 3.75	3
KA-57A-300DX	Stuffing Box Packing Ring (Duplex Stainless)A Box 3	3
KA-57A-325DX	Stuffing Box Packing Ring (Duplex Stainless)A Box 3.25	3
KA-57A-350DX	Stuffing Box Packing Ring (Duplex Stainless)A Box 3.50	3
KA-57A-375DX	Stuffing Box Packing Ring (Duplex Stainless)A Box 3.75	3
KA-57-300S	Stuffing Box Packing Ring (Steel)A Box 3	3
KA-57A-325S	Stuffing Box Packing Ring (Steel)A Box 3.25	3
KA-57A-350S	Stuffing Box Packing Ring (Steel)A Box 3.50	3
KA-57A-375S	Stuffing Box Packing Ring (Steel)A Box 3.75	3
KA-57A-300SS	Stuffing Box Packing Ring (Stainless Steel)A Box 3	3
KA-57A-325SS	Stuffing Box Packing Ring (Stainless Steel)A Box 3.25	3
KA-57A-350SS	Stuffing Box Packing Ring (StainlessSteel)A Box 3.50	3
KA-57A-375SS	Stuffing Box Packing Ring (StainlessSteel)A Box 3.75	3
KA-57C-200AB	Stuffing Box Packing Ring (ALBZ)C Box 2	3
KA-57C-225AB	Stuffing Box Packing Ring (ALBZ)C Box 2.25	3
KA-57C-250AB	Stuffing Box Packing Ring (ALBZ)C Box 2.50	3
KA-57C-275AB	Stuffing Box Packing Ring (ALBZ)C Box 2.75	3
KA-57C-300AB	Stuffing Box Packing Ring (ALBZ)C Box 3	3
KA-57C-200DX	Stuffing Box Packing Ring (Duplex Stainless)C Box 2	3
KA-57C-225DX	Stuffing Box Packing Ring (Duplex Stainless)C Box 2-1/4	3
KA-57C-250DX	Stuffing Box Packing Ring (Duplex Stainless)C Box 2-1/2	3
KA-57C-275DX	Stuffing Box Packing Ring (Duplex Stainless)C Box 2-3/4	3
KA-57C-300DX	Stuffing Box Packing Ring (Duplex Stainless)C Box 3	3
KA-57C-200S	Stuffing Box Packing Ring (Steel)C Box 2	3
KA-57C-225S	Stuffing Box Packing Ring (Steel)C Box 2.25	3
KA-57C-250S	Stuffing Box Packing Ring (Steel)C Box 2.50	3
KA-57C-275S	Stuffing Box Packing Ring (Steel)C Box 2.75	3
KA-57C-300S	Stuffing Box Packing Ring (Steel)C Box 3	3

KHORN  
PUMPS, INC.

## Kerr KA-3500 Plunger Type Pump

Part Number	Description	# Req
KA-57C-200SS	Stuffing Box Packing Ring (Stainless Steel)C Box 2	3
KA-57C-225SS	Stuffing Box Packing Ring (Stainless Steel)C Box 2.25	3
KA-57C-250SS	Stuffing Box Packing Ring (Stainless Steel)C Box 2.50	3
KA-57C-275SS	Stuffing Box Packing Ring (Stainless Steel)C Box 2.75	3
KA-57C-300SS	Stuffing Box Packing Ring (Stainless Steel)C Box 3	3
KA-58A-300	838 Plunger Packing (Non-Adjustable) 3 A Box	3 sets
KA-58A-325	838 Plunger Packing (Non-Adjustable) 3.25 A Box	3 sets
KA-58A-350	838 Plunger Packing (Non-Adjustable) 3.50 A Box	3 sets
KA-58A-375	838 Plunger Packing (Non-Adjustable) 3.75 A Box	3 sets
KA-58AG-300	858 Plunger Packing (Non-Adjustable) 3 A Box	3 sets
KA-58AG-325	858 Plunger Packing (Non-Adjustable) 3.25 A Box	3 sets
KA-58AG-350	858 Plunger Packing (Non-Adjustable) 3.50 A Box	3 sets
KA-58AG-375	858 Plunger Packing (Non-Adjustable) 3.75 A Box	3 sets
KA-58AK-300	Kevlar Packing 3 A Box	3 sets
KA-58AK-325	Kevlar Packing 3.25 A Box	3 sets
KA-58AK-350	Kevlar Packing 3.50 A Box	3 sets
KA-58AK-375	Kevlar Packing 3.75 A Box	3 sets
KA-58AT-300	Teflon Packing A-Box 3	3 sets
KA-58AT-325	Teflon Packing A-Box 3.25	3 sets
KA-58AT-350	Teflon Packing A-Box 3.50	3 sets
KA-58AT-375	Teflon Packing A-Box 3.75	3 sets
KA-58C-200	838 Plunger Packing (Non-Adjustable) 2 C Box	3 sets
KA-58C-225	838 Plunger Packing (Non-Adjustable) 2.25 C Box	3 sets
KA-58C-250	838 Plunger Packing (Non-Adjustable) 2.50 C Box	3 sets
KA-58C-275	838 Plunger Packing (Non-Adjustable) 2.75 C Box	3 sets
KA-58C-300	838 Plunger Packing (Non-Adjustable) 3 C Box	3 sets
KA-58CG-200	858 Plunger Packing (Non-Adjustable) 2 C Box	3 sets
KA-58CG-225	858 Plunger Packing (Non-Adjustable) 2.25 C Box	3 sets
KA-58CG-250	858 Plunger Packing (Non-Adjustable) 2.50 C Box	3 sets
KA-58CG-275	858 Plunger Packing (Non-Adjustable) 2.75 C Box	3 sets
KA-58CG-300	858 Plunger Packing (Non-Adjustable) 3 C Box	3 sets
KA-58CK-200	Kevlar Packing 2 C Box	3 sets
KA-58CK-225	Kevlar Packing 2.25 C Box	3 sets
KA-58CK-250	Kevlar Packing 2.50 C Box	3 sets
KA-58CK-275	Kevlar Packing 2.75 C Box	3 sets
KA-58CK-300	Kevlar Packing 3 C Box	3 sets
KA-58CT-200	Teflon Packing C-Box	3 sets
KA-58CT-225	Teflon Packing C-Box 2.25	3 sets
KA-58CT-250	Teflon Packing C-Box 2.50	3 sets
KA-58CT-275	Teflon Packing C-Box 2.75	3 sets

BUCKHORN  
PUMPS, INC.



## Kerr KA-3500 Plunger Type Pump

Part Number	Description	# Req
KA-58CT-300	Teflon Packing C-Box 3	3 sets
KA-59CS	Fluid End Capscrews	18
KA-61A-300AB	Lantern Ring ALBZ A Box 3	3
KA-61A-325AB	Lantern Ring ALBZ A Box 3.25	3
KA-61A-350AB	Lantern Ring ALBZ A Box 3.50	3
KA-61A-375AB	Lantern Ring ALBZ A Box 3.75	3
KA-61A-300S	Lantern Ring Steel A Box 3	3
KA-61A-325S	Lantern Ring Steel A Box 3.25	3
KA-61A-350S	Lantern Ring Steel A Box 3.50	3
KA-61A-375S	Lantern Ring Steel A Box 3.75	3
KA-61A-300SS	Lantern Ring Stainless Steel A Box 3	3
KA-61A-325SS	Lantern Ring Stainless Steel A Box 3.25	3
KA-61A-350SS	Lantern Ring Stainless Steel A Box 3.50	3
KA-61A-375SS	Lantern Ring Stainless Steel A Box 3.75	3
KA-61C-200AB	Lantern Ring ALBZ C Box 2	3
KA-61C-225AB	Lantern Ring ALBZ C Box 2.25	3
KA-61C-250AB	Lantern Ring ALBZ C Box 2.50	3
KA-61C-275AB	Lantern Ring ALBZ C Box 2.75	3
KA-61C-300AB	Lantern Ring ALBZ C Box 3	3
KA-61C-200S	Lantern Ring Steel C Box 2	3
KA-61C-225S	Lantern Ring Steel C Box 2.25	3
KA-61C-250S	Lantern Ring Steel C Box 2.50	3
KA-61C-275S	Lantern Ring Steel C Box 2.75	3
KA-61C-300S	Lantern Ring Steel C Box 3	3
KA-61C-200SS	Lantern Ring Stainless Steel C Box 2	3
KA-61C-225SS	Lantern Ring Stainless Steel C Box 2.25	3
KA-61C-250SS	Lantern Ring Stainless Steel C Box 2.50	3
KA-61C-275SS	Lantern Ring Stainless Steel C Box 2.75	3
KA-61C-300SS	Lantern Ring Stainless Steel C Box 3	3
KA-62-200	316 Stainless Steel Plungers 2	3
KA-62-225	316 Stainless Steel Plungers 2.25	3
KA-62-250	316 Stainless Steel Plungers 2.50	3
KA-62-275	316 Stainless Steel Plungers 2.75	3
KA-62-300	316 Stainless Steel Plungers 3	3
KA-62-325	316 Stainless Steel Plungers 3.25	3
KA-62-350	316 Stainless Steel Plungers 3.50	3
KA-63-200	Colmonoy Plungers 2	3
KA-63-225	Colmonoy 730 Plungers 2.25	3
KA-63-250	Colmonoy 730 Plungers 2.50	3
KA-63-275	Colmonoy 730 Plungers 2.75	3

BUCKHORN  
PUMPS, INC.



## Kerr KA-3500 Plunger Type Pump

Part Number	Description	# Req
KA-63-300	Colmonoy 730 Plungers 3	3
KA-63-325	Colmonoy 730 Plungers 3.25	3
KA-63-350	Colmonoy 730 Plungers 3.50	3
KA-63-375	Colmonoy 730 Plungers 3.75	3
KA-64LH	Plunger Chamber Cover (For LH Drive Pumps)	1
KA-64RH	Plunger Chamber Cover (For RH Drive Pumps)	1
KA-67	Wing-Guided Seat Eccentric Type Puller Ass'y	1
KA-68	Disc Seat Threaded Stem Type Puller Ass'y	1
KA-68M	Wing-Guided Seat Tri-Pin Type Puller Ass'y	1
KA-68M-1	Rod, Puller	1
KA-68M-2	Pin Set, Puller	3
KA-68M-3	Head, Puller	1
KA-68M-4	Spacer Washer, Puller	1
KA-68M-5	Nut, Puller	1
KA-68M-6	O-Ring, Puller	1
AP-71	Drain Plug	1
AP-72S	1/8 NPT Oil Level/Stuffing Box Hex Plug (Steel)	3
AP-72SS	1/8 NPT Oil Level/Stuffing Box Hex Plug (Stainless Steel)	3
AP-72	1/8 NPT Oil Level/Stuffing Box Hex Plug (AB)	3
KA-72HT	Discharge Valve, Heat Treated A/R with Insert	3
KA-73HT	Suction Valve, Heat Treated A/R with Insert	3
KA-74HT	Valve Seat, Heat Treated A/R	6
KA-77A	Abrasive Resistant Valve Insert Aflas	6
KA-77B	Suction Valve Insert Blue	6
KA-77HT	Abrasive Resistant Valve Insert (High Temperature)	6
KA-77R	Abrasive Resistant Valve Insert Discharge Red	6
KA-77V	Abrasive Resistant Valve Insert Viton	6
KP-85B	Abrasive Resistant Valve Insert Blue	3
KP-85R	Abrasive Resistant Valve Insert Red	3
KA-88VG-275	758 Pressure Rings 2 3/4	4 Rings Pe
KA-90GSL-275AB	758 SF Spring Loaded Lube Packing Set 2 3/4 (ALBZ)	3
KA-90GSL-275S	758 SF Spring Loaded Lube Packing Set 2 3/4 (Steel)	3
KA-90GSL-275SS	758 SF Spring Loaded Lube Packing Set 2 3/4 (Stainless Steel)	3
KA-93SLL-275AB	Packing Adapters Spring Loaded W/ Lube Ring 2-3/4 ID (ALBZ)	3
KA-93SLL-275S	Packing Adapters Spring Loaded W/ Lube Ring 2-3/4 ID (Steel)	3
KA-93SLL-275SS	Packing Adapters Spring Loaded W/ Lube Ring 2-3/4 ID (Stainless Steel)	3
KA-95W-425	Wave Spring 4-1/4 OD	3
KA-113	KA-3500 Rebuild Gasket Kit Complete Includes the Following Parts:(1) KA-3, (2) KA-7, (1) KA-12, (3) KA-26G, (3) KA-28, (3) KA-32, (6) KA-38, (3) KA-54	1
KA-114	Lubrication System Complete	1
KA-114DL	1 Gallon Drip Oiler w/Plunger Cover	1

## Kerr KA-3500 Plunger Type Pump

Part Number	Description	# Req
AP-114	Force Feed Lubricator 3 Feed	1
AP-115	Check Valve Stainless Steel 1/8 Pipe	3
KA-115	Lubrication System Less Lubricator	1
KA-115H	Lubricator Hose Kit Complete	1
AP-116	55 Single Pump for Forced Feed Lubricator	3
KA-117	Crankshaft Lubrication Sheave	1
AP-117L	Lubricator Sheave	1
KA-118	Lubrication Belt	1
KA-119	Lubricator Bracket	1
KA-120-8	Crankshaft, Splined Hydraulic Drive 21 Tooth Spline	1
KA-125-8	Bearing Housing, Hydraulic Drive # 8	1
KA-126BH	Bearing Cap Lifting Eye	1
KA-126FE	Fluid End Lifting Eye	1
KA-127	#8 Auburn Housing Gasket	1
KA-130	Bearing Housing, Extension Shaft Side	1
AP-132	Auxiliary Shaft	1
AP-135	Oil Seal, Bearing Housing Extension Shaft	1
KAC-200	Ceramic Plungers 2	3
KAC-225	Ceramic Plungers 2.25	3
KAC-250	Ceramic Plungers 2.50	3
KAC-275	Ceramic Plungers 2.75	3
KA-276	Installation Tool for Pony Rod Seal	1
KA-277	Pony Rod Installation Wrench	1
KA-300AR	A. R. Discharge Valve Complete (72HT,74HT & 52L)	3
KA-300AB	ALBZ Discharge Valve Complete (KA-46, KA-48 & KA-52L)	3
KA-300M	Monel Discharge Valve Complete (KA-49,KA-48 & KA-52L)	3
KA-300SS	Stainless Steel Discharge Valve Complete (72HT, 74HT & 52L)	3
KAC-300	Ceramic Plungers 3	3
KA-305AR	A. R. Suction Valve Complete (73HT, 74HT & 52S)	3
KA-305AB	ALBZ Suction Valve Complete (KA-47, KA-48 & 52S)	3
KA-305M	Monel Suction Valve Complete (KA-50, KA-48 & KA-52S)	3
KA-305SS	Stainless Steel Suction Valve Complete (73HT, 74HT & 52S)	3
KA-306	Valve Seat Seating Tool	1
AP-324-7.07:1	# 8 Planetary Gear Kit 7.07:1	1
AP-324-6.0:1	#8 Planetary Gear Kit 6.0:1	1
AP-324-5.5:1	#9 Planetary Gear Kit 5.5:1	1
AP-324-4.8:1	#8 Planetary Gear Kit 4.8:1	1
KAC-325	Ceramic Plungers 3.25	3
AP-330	SAE C 4 Bolt Drive Assembly 1-1/2 Male Input Shaft	1
AP-330H	Housing, SAE C 4 Bolt Drive Assembly 1-1/2 Male Input Shaft	1

SUCKTHORN  
PUMPS, INC.

## Kerr KA-3500 Plunger Type Pump

Part Number	Description	# Req
AP-330S	Input Shaft, SAE C 4 Bolt Drive Assembly 1-1/2 Male Input Shaft	1
AP-330B	Bearings, SAE C 4 Bolt Drive Assembly 1-1/2 Male Input Shaft	2
AP-330-1	Oil Seal, SAE C 4 Bolt Drive Assembly 1-1/2 Male Input Shaft	1
AP-330-2	Snap Ring, SAE C 4 Bolt Drive Assembly 1-1/2 Male Input Shaft	1
KAC-350	Ceramic Plungers 3.50	3
AP-351	Oil Level Sight Glass	1
AP-352	Oil Level Sight Plug	1
KAC-375	Ceramic Plungers 3.75	3
AP-425	Stuffing Box Nut Wrench	1
AP-450	Sunstrand Hyd Mtr 90 Series	1
KA-500HT	Valve Ass'y, Complete A/R Caged (KA-501HT, KA-502HT, KA-504, KA-506, KP-85 & KA-KT-42-3)	3
KA-501HT	Seat, Valve, Heat Treated	5
KA-502HT	Valve w/Insert, Heat Treated	5
KA-504HT	Cage, Valve	5
KA-506	Valve Seat O'Ring	6
KA-550	Cage Wrench	1
KA-555	Disc Seat J Type Puller Ass'y	1
KA-555-1	Disc Seat J Type Puller (Head Only)	1
KA-800-200	Plunger, Kerramic 2	3
KA-800-225	Plunger, Kerramic 2-1/4	3
KA-800-250	Plunger, Kerramic 2-1/2	3
KA-800-275	Plunger, Kerramic 2-3/4	3
KA-800-300	Plunger, Kerramic 3	3
KA-800-325	Plunger, Kerramic 3-1/4	3
KA-800-350	Plunger, Kerramic 3-1/2	3
KA-800-375	Plunger, Kerramic 3-3/4	3

All prices and part numbers are subject to change without prior notice.

BUCKHORN  
PUMPS, INC.