

Service Manual

Kerr Q5450PT Piston Pump

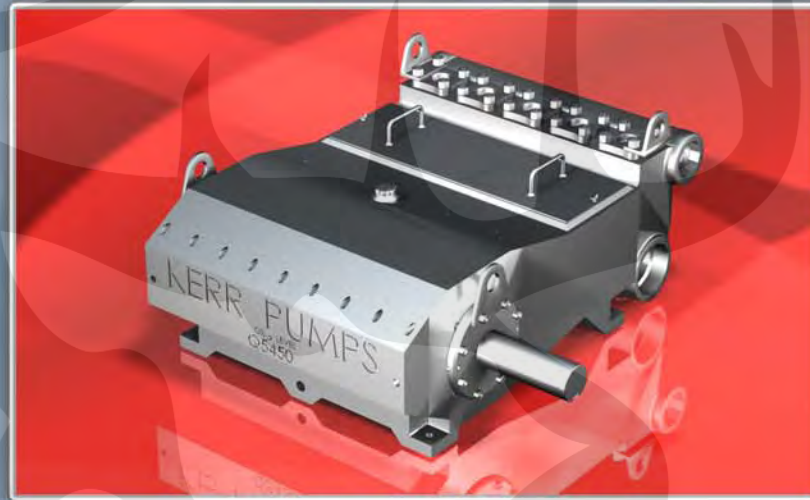

Post Office Box 735 2214 West 14th St.
Sulphur, Oklahoma 73086
Phone: 580-622-4207 Fax: 580-622-4206
Web Site: www.kerrpumps.com
Email: information@kerrpumps.com

United States and Canada
800-441-8149



Since 1946

BUCKHORN
PUMPS, INC.

KERR PUMP CORPORATION SERVICE MANUAL

HDD 2ND EDITION



NEW PUMP WARRANTY

- A. Kerr Machine Company (**Kerr Pump Corporation**) warrants its new HDD pumps to be free from defective materials and/or workmanship for 1000 HOURS OR ONE (1) YEAR, whichever comes first, from date of sale by distributor, provided that the new pump is registered in accordance with Paragraph No. 2 hereof, properly installed and operated in accordance with the Company's Service Manual, and all other terms of this warranty agreement are complied with by the purchaser. As hereinafter provided, this warranty includes the replacement of parts and labor to correct any deficiency. All defective parts must be returned to the Company's Home Office for examination before this warranty is effective. This warranty applies to parts, which have been replaced under this warranty only so long as the original pump warranty is effective. This warranty is for the exclusive benefit of the purchaser and is not transferable.
- B. Each Distributor of a new pump will provide the customer with a registration blank furnished to him by the Company which must state the date of sale, be signed by the purchaser and the Distributor, and delivered to the Home Office of the Company within fifteen (15) days of the date of sale.
- C. In the event of a claim under this warranty, made within the 1000 HOUR warranty period, the purchaser must notify the Distributor, and the Distributor shall contact **Kerr Pump Corporation** before any repairs or service calls are made.
- D. All warranty claims must be sent to Kerr Pump Corporation Home Office on the authorized warranty claim form provided by **Kerr Pump Corporation** and available from the Distributor before any warranty claim will be considered. It is understood that a pump will deteriorate due to ordinary wear therefore; the following credits shall apply to all replacement parts, labor, surface freight, travel-time and mileage allowance furnished under this warranty.

BUCKHORN
PUMPS, INC.

FOR 1000 HOUR CLAIMS

- i. For the first 250 hours, 100% credit will be allowed on a current list price basis.
- ii. From 251 hours to 500 hours, 75% credit will be allowed on a current list price basis.
- iii. From 501 hours to 750 hours, 50% credit will be allowed on a current list price basis.
- iv. From 751 hours to 1000 hours, 25% credit will be allowed on a current list price basis.

The credit given to the Distributor for replacement parts or pumps under this warranty is based upon the Distributor's net cost paid Kerr Pumps for such replacement parts or pumps.

- E. In the event of a warranty claim under this warranty is made within the first 250 hours, **Kerr Pump Corporation**, before any repairs begin, shall be contacted by the Distributor and given the option of having the Distributor either repair or replace the pump.
- F. Upon any claim under this warranty, other than a claim wherein **Kerr Pump Corporation** at its option replaced the pump as provided in Item 'E' hereof, the Distributor will make the necessary repairs and/or replacement, and **Kerr Pump Corporation** shall allow the cost of labor on warranty claims. The labor cost may include travel time not to exceed (8) hours of actual travel time. **Kerr Pump Corporation** will pay surface freight on warranty shipments. After making the necessary repairs and/or replacements, the Distributor will bill the customer for the full amount due for the repair. Thereafter, the Distributor will submit the warranty claim form provided by **Kerr Pump Corporation** to the **Kerr Pump Corporation** Home Office for consideration. In the event the warranty claim is honored by **Kerr Pump Corporation**, a Credit Memorandum will be issued to the Distributor in the amount determined by the table in Item 'D' hereof. Thereafter, the customer's invoice will be credited by the Distributor in the same percentage allowed the Distributor by **Kerr Pump Corporation**.

If requested by **Kerr Pump Corporation** the purchaser or the Distributor shall return the alleged defective product to **Kerr Pump Corporation** factory, freight prepaid, for examination and testing. If **Kerr Pump Corporation** determines the product is defective, **Kerr Pump Corporation** will either repair or replace such product with a 'like' **Kerr Pump Corporation** manufacture, f.o.b. to the Distributor or allow the Distributor credit to an amount equal to the invoiced value of the defective product. The responsibility of **Kerr Pump Corporation** is limited to the repairing or replacing defective material manufactured by it, provided **Kerr Pump Corporation** examination discloses to its satisfaction that such material has not been altered or repaired, other than by **Kerr Pump Corporation** approved procedures, subject to misuse, improper maintenance, negligence or accident. **Kerr Pump Corporation** will not be responsible for loss of

liquid or for damage of any kind, or from any cause, to any person or property of any person, or for loss of revenue of profit, or for any other special incidental or consequential damages.

- G. The warranty applies only to new pumps. The Company specifically excludes from this warranty the following.
 - i. All pistons, piston rubbers, liners, valves, valve springs, seals gaskets, and corrosion and/or erosion damage caused by the fluid handled by the Company's pump.
 - ii. In addition, after the expiration of the pump warranty, all replacement parts are no longer in warranty.
- H. In extreme cases where in the opinion of **Kerr Pump Corporation**, if a pump has been misused or is being misused, **Kerr Pump Corporation** reserves the option to offer to redeem the pump from the purchaser. Should the purchaser refuse to allow the pump to be redeemed and chooses to continue improper operation, the warranty will be void.
- I. Any parts or equipment which **Kerr Pump Corporation** supplies and does not manufacture shall be subject only to the warranties of **Kerr Pump Corporation** vendors to the extent **Kerr Pump Corporation** can enforce such warranties.
- J. Any repairs to, alterations of, or work done on alleged defective products without **Kerr Pump Corporation** specific written authorization shall void **Kerr Pump Corporation** warranty applicable thereto.
- K. Any action for breach of warranty or other action under this agreement must be commenced within (1) year after such cause of action arises.

This limited warranty is in lieu of all other warranties, expressed or implied, including any implied warranty or merchantability or fitness.

BUCKHORN
PUMPS, INC.

TOUBLESHOOTING

Problem	Reason/Solution
Unusual pounding, knocking broken valve spring	<ul style="list-style-type: none">• Insufficient fluid at high speed.• Suction line is improper size or is constricted. (Trash in line, valve partly opened, etc.)• Possibility of gas in the fluid causing the roughness.
Loss of pressure or volume	<ul style="list-style-type: none">• Foreign matter may be holding valves open.• Worn valves.• Broken springs.
Consistent, rhythmic knock	<ul style="list-style-type: none">• Improper bearing adjustment.• Worn bearings or connecting rods.• NOTE: Valve noise is common and normal in high-speed pumps. It should not cause concern unless it becomes erratic.
Packing failure (Excessive)	<ul style="list-style-type: none">• Improper installation.• Improper type of lubrication.• Incorrect type of packing for particular installation.• (Contact Kerr Pump Corporation if you are unsure.)
Abnormal wear of fluid end parts	<ul style="list-style-type: none">• Abrasive or corrosive fluid.
Abnormal wear of power end parts	<ul style="list-style-type: none">• Lack of oil, overload on pump, foreign matter in oil.
Heat in power end	<ul style="list-style-type: none">• A new pump will run hot for a short period (2 or 3 days). See above for persistent heating. Pump will operate near 140° F. under average conditions.• Check for air in pump by bleeding at cover caps.• Too much spring tension Reciprocating pumps have very limited pick up.

BUCKHORN
PUMPS, INC.

INSTALLATION INSTRUCTIONS



WARNING

Read everything in this section before attempting to run or connect your pump.

The importance of proper installation cannot be overstressed. As the reciprocating pump is almost unable to lift fluid, proper suction flooding is a must. This is the First step toward satisfactory operation.

For best results, follow these installation guidelines.

- (A) PRESSURE RELIEF VALVE (REQUIRED)
- (B) BY-PASSED FLUID SHOULD BE PIPED BACK IN SUCTION SUPPLY TANK WHEN POSSIBLE
- (C) USE FLEXIBLE HOSE IN DISCHARGE LINE WHEN POSSIBLE
- (D) DISCHARGE SHUT-OFF VALVE (OPTIONAL-USED FOR TOTAL SHUT-DOWN OR SERVICE ONLY)
- (E) DISCHARGE AND SUCTION ON EITHER SIDE OF FLUID END ON ALL MODELS.
- (F) PULSATION “DAMPENERS” MAY BE USED IN EITHER THE SUCTION OR DISCHARGE PIPING OR BOTH. DISCHARGE DAMPENERS SHOULD BE CAPABLE OF HANDLING PUMP DISCHARGE MAXIMUM PRESSURE

The Kerr Pumps Engineering Service will be happy to advise you in your installation problems. As almost every installation varies, you cannot exercise too much care in making certain your installation is proper.

To start the pump, open the suction line valve and permit the intake chamber to fill on the pump. Air may be bled off by opening the valve covers slightly until there is a constant fluid flow. After bleeding, open the discharge line valve and start the pump. Roughness may occur from cavitations (air in line) or from starvation (lack of fluid). Eliminate these troubles before permitting continuous operation.

**BUCKHORN
PUMPS, INC.**

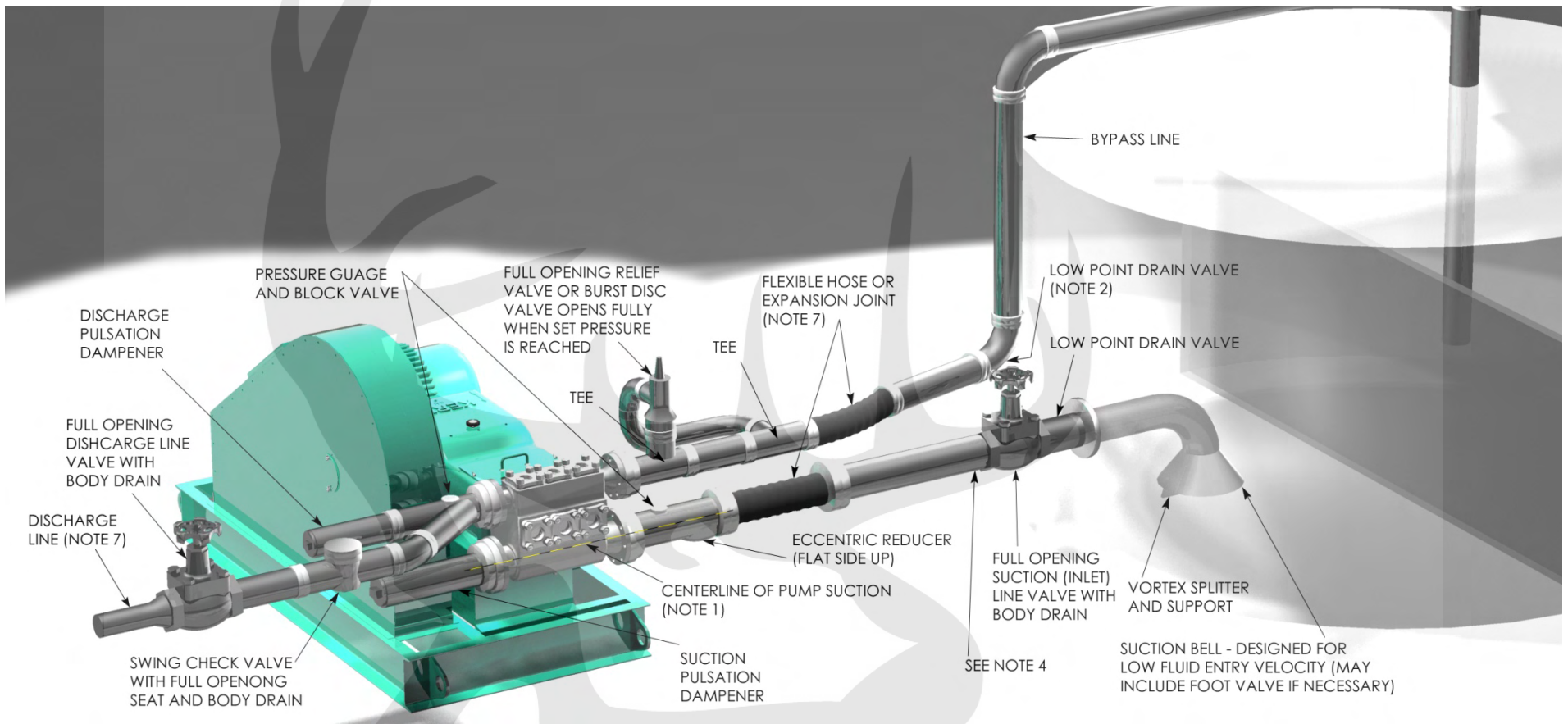

- 1) CENTERLINE OF PUMP SUCTION (INLET) TO BE SLIGHTLY HIGHER THAN CENTERLINE OF SUCTION (INLET) VALVE SO ANY AIR IN SUCTION SYSTEM PROMPTLY REACHES PUMP AND IS EXPELLED – A SLOPE OF ¼" PER FOOT IS BEST
- 2) SLOPE BYPASS LINE SO LOW POINT DRAIN WILL FULLY EMPTY RELIEF AND CHOKE VALVES AND ALL LIQUID IN BYPASS CIRCUIT
- 3) DO NOT LOCATE PIPING OR OTHER EQUIPMENT IN FRONT OF OR ABOVE PUMP FLUID END PREVENTING SERVICING – REFER TO MANUFACTURER FOR MINIMUM CLEARANCES
- 4) LOCATE CHARGING PUMP AT POINT SHOWN. – IF CHARGING PUMP IS NECESSARY (FOR VOLATILE FLUIDS, FOR EXAMPLE)
- 5) IF DESIRED, A TWO-WAY MOTOR OPERATED BYPASS VALVE MAY BE USED RATHER THAN MANUAL TYPE – IT SHOULD BE DESIGNED TO OPEN AUTOMATICALLY WHILE STARTING OR STOPPING
- 6) BYPASS LINE SHOULD FEED LIQUID INTO TANK BELOW MINIMUM LIQUID LEVEL
- 7) TO REMOVE PIPING STRAIN AND VIBRATION A FLEXIBLE HOSE, EXPANSION JOINT OR SWIVEL JOINT PAIR SHOULD BE POSITIONED TO MINIMIZE EFFECTS OF PIPING THERMAL EXPANSION, CONTRACTION AND PIPING WEIGHT
- 8) SUCTION SIZED FOR 1 ½ TO 2 FT/SEC MAX FLOW RATE. DISCHARGE SIZED FOR 8 TO 10 FT/SEC MAX FLOW RATE – SUCTION AND DISCHARGE MUST BE SUPPORTED AND ANCHORED
- 9) TO PROTECT SUCTION SYSTEM AGAINST HAZARD OF DISCHARGE PRESSURE ENTRY (AS WHEN PUMP IS IDLE), A SMALL RELIEF VALVE IS OFTEN CONNECTED HERE
- 10) ALL SYSTEM COMPONENTS MUST HAVE ADEQUATE PRESSURE RATINGS FOR OPERATING, STARTING AND UPSET CONDITIONS. IN ORDER TO REDUCE POTENTIAL HAZARDS, PARTICULAR ATTENTION IS RECOMMENDED FOR THE SURGE CONDITION THAT WILL RESULT DOWNSTREAM OF THE RELIEF VALVE WHEN NORMAL DISCHARGE IS BLOCKED



-AS A GENERAL RULE, FLUID LEVEL MUST BE HIGHER THAN THE PUMP FLUID END AS PLUNGERS CANNOT LIFT FLUID. 10 FEET OF HEAD IS A GOOD RULE OF THUMB.
 -CAUTION SHOULD BE TAKEN TO KEEP FITTINGS OUT OF THE SUCTION AND DISCHARGE PIPING AS THESE WILL RESULT IN POOR PERFORMANCE.
 -IF BENDS ARE NECESSARY USE 45° LONG RADIUS ELLS INSTEAD OF 90° ELLS.

BUCKLEUP
 PUMPS, INC.

PREVENTIVE MAINTENANCE

DAILY

A. Check and Maintain Lubricant Levels.

Standard Lubricant:		Synthetic Lubricant:	
AGMA Grade (ASTM D 2422)	4 EP	SAE Viscosity Grade (J306-8)	75W-90
ISO Viscosity Grade	150		
Viscosity in SSU @ 100 degree F	625-765		

PUMP CAPACITIES (APPROXIMATE)

KD-1250	2 qts.	KT-3350	16 qts.
KJ-2250	3 qts.	KT-3400	16 qts.
KZ-3150	2 qts. <i>Use SAE 30 weight non-detergent motor oil ONLY</i>		
KM-3250	4 qts.	KB-3500	20 qts.
KM-3300	4 qts.	KA-3500	36 qts.
KP-3300	12 qts.	KSB-6400	36 qts.
R335/R340	16 qts.	KSB-6500	36 qts.
Q5450	22.5 gal.	KCP-6300	24 qts.

PLANETARY GEAR REDUCERS

#6	17 ozs.
#8	42 ozs.
#9	42 ozs.

BUCKHORN
PUMPS, INC.

- B. If pump has lubricating facilities for stuffing boxes, check level of lubricant.
- C. Maintain packing gland tension on packing (Do not over-tighten)
- D. Visually inspect pump for apparent trouble.
- E. Keep the pump clean.

MONTHLY

- A. Drain and refill crankcase. It is recommended that oil be changed after the first week of operation.
- B. Wash oil filler cap in kerosene.
- C. Check valves for excessive wear, broken or bent springs, etc.
- D. Check crankshaft bearings for endplay. (See section on crankshaft)
- E. Keep all nuts, studs, etc. tight.
- F. Check valve covers for leaks.
- G. Check all seals and gaskets for leaks

GENERAL

Replace any work part before its eventual failure. Use the following instructions for removal and replacement of parts. Don't hesitate to call on Kerr Pump Corporation for help if necessary at 1-800-441-8149.

SERVICE PROCEDURES (ALL MODELS)

A. VALVES (Wing-guided type):

- i. **DISCHARGE VALVE:** The discharge valve and seat can be exposed by first removing the discharge valve cover cap. Once the discharge cover cap has been removed you may lift out the discharge valve spring and the discharge valve. The valve seat will be held in place by a taper fit and must be "pulled" with an appropriate valve-pulling tool (available from the **KERR PUMPS** Dealers). Once the valve and seat have been removed they should be resurfaced or replaced if badly worn. To replace the discharge valve,

first clean and inspect the seat bore for washout defects and then drop the seat into the bore. Replace the valve into the seat and strike the top of the valve a couple of good blows utilizing a brass bar and hammer to seat the valve seat in the fluid end valve bore. Replace the valve spring and cover cap after inspecting the spring and the seal of the cover cap.

- ii. SUCTION VALVE: The suction valves are located in the chamber directly behind the suction or end valve cover caps. The suction valves are serviced in the identical manner as the discharge valves. Note: Discharge valves must be removed prior to any removal of the suction valves.

Service Procedure for KZ-3150PT Valves

- iii. DISCHARGE VALVE: The discharge valve and seat can be exposed by first removing the discharge valve cover plate. Once the discharge cover cap has been removed you may lift out the discharge valve spring, discharge valve and valve seat. Once the valve and seat have been removed they should be replaced if badly worn. To replace discharge valve, first clean and inspect the seat bore for wash out defects and then drop the seat into the bore. Replace valve in seat then valve spring and cover cap, always-inspecting O-ring seals between seats and cover caps.
- iv. SUCTION VALVE: The suction valves are located in the chamber directly below the discharge valve seat. The suction valves are serviced in the identical manner as the discharge valves.

B. PONY ROD and PONY ROD PACKING: Pumps use two pony rod sealing arrangements, models KM-3250PT and KM-3300PT use a screw in seal gland, all other models use a bolt in seal gland, these glands use press in oil seals with snap ring retainers. Some bolt in gland use adjustable packing arrangements with bolt in or screw in followers to adjust packing. By unscrewing plunger from pony rod a gap may be facilitated to allow the removal of the various sealing arrangements. A special wrench will be needed to remove and replace pony rod to crosshead. (This wrench is available from **Kerr Dealers**) All pony rods have a jam nut to align tighten pony rod to crosshead, care must be exercised in installing new seal on pony rod not to damage it.

C. DISASSEMBLY OF POWER END.



CAUTION: Prior to disassembly of any power end, the plunger, pony rod, and pony rod seal housing must be removed.

Expose the crankshaft and connecting rods by removing the pan cover. Connecting rod caps may now be removed and the connecting rod and crosshead should be shoved all the way to the rear (toward the fluid end) to facilitate crankshaft removal out either side as convenient. The connecting rods and crossheads may now be taken out the front cavity exposed by removing the crankshaft.

Connecting rods may be removed from the crosshead by loosening the setscrew and driving out the wrist pin from the crosshead. A bronze bushing is used in the rod it may be driven out of the rod and replaced with a new bushing. Reassembly is the reverse of the above outlined sequence with the following considerations for “fits” or tolerance:

- i. General: All Kerr components are machined on modern production machine tools and are of the same specifications and close tolerances you would expect in a modern automobile engine. It must be pointed out that at top speed (350 to 400 RPM) your pump will not even be approaching idle speed for a gasoline engine so “field fits” are possible and practical when making repairs and replacements away from the factory. All procedures outlined below are possible with only hand tools and absolutely no instruments, special tools, or gauges are needed.
- ii. Connecting rod and wrist pin: Proper fit will find the wrist pin turning freely in its bore in the connecting rod, but it should have no “wobble” that is discernable up and down the main axis of the connecting rod. This looseness in the wrist pin fit is the most probable cause of “knocking” which is traceable to the power end of most all pumps. The only solution for loose fitting wrist pins is to discard the connecting rod wrist pin bushing and replace with a new one. If any wear is visible on the wrist pin it should always be replaced.
- iii. Crankshaft End Play and Lateral adjustments: Adjustment of the Taper Roller bearings used in all Kerr Pumps is accomplished by removing or adding shims under the bearing housing. Shims are taken out or added until the crankshaft (without connecting rods) will turn freely, but with no endplay felt when attempting to pull or push the jackshaft end of the crankshaft along its long axis. Some lateral adjustment is possible by removing shims from one side of the crankshaft and adding them to the opposite side. (Note: Lateral adjustment is the “centering” of the crankshaft in the power frame housing.)
- iv. Connecting Rod to Crankshaft fitting: Factory bored connecting rods will normally fit the standard crankshaft journal just by bolting the cap on the rod with the standard rod shims being used. If the caps do require adjustment this is accomplished by removing or adding various thicknesses of rod shims. The standard connecting rod shim used on all Kerr Pumps is 1/32” thick and is comprised of .002” laminates, which can be “pealed “ off separately. Proper fit of the connecting rod will allow the pump crankshaft to be rotated while not allowing in-and-out slack in the connecting rod along its long or main axis. A well-fitted rod will have none of the in-and-out slack, but should be free enough to be moved from side to side on the rod journal. This insures the rod not being too tight. A point of caution when installing the connecting rod assembly in the pump is to make certain the oil holes in the rod are “UP” and not toward the bottom of the pump. This will result in lubrication failure in these parts and the pump will fail in a short period of time. An additionally important step is to make sure that the rod cap is bolted back on the rod

as it came off. The rod and cap carry a “mark” or “number” which allows you to match them back properly. Failure to do this will cause the rod not to fit the journal for which it was made.

- D. Power End/Fluid End Connection: A common misconception is that there is some form of fluid seal between the power end and the fluid end. This is false. The fluid end is merely bolted to the power frame. To take off the Fluid End all the Liners must be removed by unthreading all retainer Nuts from each retainer Stud, sliding off each liner Retainer, followed by any unscrewing all other power frame to fluid end cap screws, removing the Piston Rod Clamp, then safely sliding the Fluid End away from the Power Frame.





TECHNICAL DATA SHEET

T.D.S. NO. 4.2

PCN: _____

Supersedes PCN: _____

Date 03-10-06

SHORT TERM STORAGE PREPARATION PROCEDURE

1.0 SCOPE

This procedure applies to Kerr Pumps ONLY. Storage procedures for any other unit components or accessories (gear reducers, engines, etc.) are to be prepared to the specific manufacture's recommendations.

- 1.1 Short-term storage is defined as storage and/or transient time less than six (6) months in an environment defined in Paragraph 2. If storage exceeding six months is expected, the Long Term Pump Storage Preparation Procedure should be followed.
- 1.2 Kerr Pumps will only prepared for short term storage if so specified in the purchaser or customer order control document.

2.0 STORAGE ENVIRONMENT

A minimal environmental condition, to be met by the customer or purchaser, is a closed shelter to eliminate effects of sun, wind, sand or other debris. Large temperature and humidity changes should be avoided to prevent coating deterioration or contamination by moisture.

3.0 PRESERVATIVE PRODUCT

- 3.1 The specified rust preservative will protect the internal power end parts from corrosion due to atmospheric moisture, and may be left in the pump when filled with appropriate lubricant and placed into service. The elevated temperature of service will cause rapid depletion of the preventative protection.
- 3.2 The following rust preventative products or their equivalents are recommended for use in Kerr Pumps and usually available in 5 gallon, 55 gallon containers:
 - CITGO: RUST-O-LINE OIL 10
 - SHELL: ENSIS OIL N

4.0 PROCEDURE

- 4.1 Preparation from; factory testing, inventory, or a distributor rebuild facility.
 - Drain any oil that may be in the power end, and then fill the complete power end cavity with the specified rust preventative. After 15 to 20 minutes, drain the rust preventative back into its storage drum for future use.
 - Remove and clean oil level gages, pressure gages and breather caps. Replace with pipe plugs in threaded openings. All breathers shall be replaced with airtight seals, plugs or gasketed plates. No venting is recommended as it may allow moist air in.

TECHNICAL DATA SHEET

T.D.S. NO.

4.2

PCN: _____

Supersedes PCN: _____

Date 03-10-06

- 4.1.1 Remove the wiper box seals and cap/plug the seal opening.
- 4.1.2 Clean the pump outer surfaces prior to painting.
- 4.1.3 If painting is required mask crank and lubricator shaft surfaces and keyways. If painting does not apply, go to Para. 4.1.8.
- 4.1.4 Paint as specified by the customer order or as required.
- 4.1.5 Apply a thin layer of grease to the exposed oil seal lips.
- 4.1.6 Apply a thin layer of heavy rust preventative to the exposed crank and lubricator shaft surfaces and keyways.
- 4.1.7 Wrap the exposed crank and lubricator shafts with waxed tape.
- 4.1.8 Carefully wrap the following parts prior to placing them into polyurethane bags. Oil level gages, lube pressure gages, and breather caps.
- 4.1.9 Finish box, crate and mark the parts from Para. 4.1.2 after final inspection (see Para. 4.2.2).
- 4.2 Shipping/Receiving (New Pumps Only)
 - 4.2.1 All pumps and accessories (as applicable) will be final inspected by Kerr Pump personnel prior to shipping. Any witnessed or third party inspection will be signed-off by the purchaser or customer representative prior to final crating and shipment.
 - 4.2.2 Export crating will be performed by either an approved Kerr Pump source or as specified by the purchaser or customer. Any third party inspection will be coordinated with the source.
 - 4.2.3 Upon receipt of the shipment, the purchaser or customer is responsible for inspection and repair of damaged coatings at the expense of the shipper.

5.0 WARRANTY/START-UP

- 5.1 Pumps prepared per the above procedure qualify for the "Standard Terms & Conditions" in force on the date of shipment.
- 5.2 If the pump storage period is less than 6 months, follow the Short Term Pump Preparation Procedure.
- 5.3 Prior to start-up:
 - 5.3.1 Remove all storage caps, plugs, and covers.
 - 5.3.2 Replace any damaged or cracked O-rings or gaskets.
 - 5.3.3 Inspect power end shaft oil seals and replace if cracked, split or damaged.
 - 5.3.4 Install crankcase drain plug, lubrication level site glass and breather cap.
 - 5.3.5 Install, if applicable, any oil pressure and/or temperature gage.
 - 5.3.6 Check the connection of the plunger and pony rod to the crosshead prior to, and after, initial run-in of the pump.
 - 5.3.7 Fill the crankcase to the proper level with the specified lubricant.

BUCKHORN
PUMPS, INC.

TECHNICAL DATA SHEET

T.D.S. NO.

4.3

PCN: _____

Supersedes PCN: _____

Date

03-10-06

TITLE: LONG TERM STORAGE PREPARATION PROCEDURE

1.0 SCOPE

This procedure applies to Kerr Pumps ONLY. Storage procedures for any other unit components or accessories (gear reducers, engines, etc.) are to be prepared to the specific manufacture's recommendations.

1.1 Long-term storage is defined as storage and/or transient time exceeding six (6) months in an environment defined in Paragraph 2. If storage for less than six months is expected, the Short Term Pump Storage Preparation Procedure should be followed.

1.2 Kerr Pumps will only prepare for short term storage if so specified in the purchaser or customer order control document.

2.0 STORAGE ENVIRONMENT

A minimal environmental condition, to be met by the customer or purchaser, is a closed shelter to eliminate effects of sun, wind, sand or other debris. Large temperature and humidity changes should be avoided to prevent preventative deterioration or contamination by moisture.

3.0 RUST PREVENTATIVE PRODUCT

3.1 The recommended rust preservative should protect the internal power end parts from corrosion due to atmospheric moisture, and may be left in the pump when filled with appropriate lubricant and placed into service. The elevated temperature of service will cause rapid depletion of the preventative protection.

3.2 The following rust preventative products or their equivalents are recommended for use in Kerr Pumps and usually available in 5 gallon, 55 gallon containers:

CITGO: RUST-O-LINE OIL 10

SHELL: ENSIS OIL N

4.0 PROCEDURE

4.1 Preparation from; factory testing, inventory, or a distributor rebuild facility.

4.1.1 Drain any oil that may be in the power end and then fill the complete power end cavity with the specified rust preventative. After 15 to 20 minutes, drain the rust preventative back into its storage drum for future use.

4.1.2 Remove all plungers, pony rods (if applicable), baffle discs, packing and junk rings.

4.1.3 Remove and clean oil level gages, pressure gages and breather caps. Replace with pipe plugs in threaded openings.

KERR
PUMPS, INC.

TECHNICAL DATA SHEET

T.D.S. NO. 4.3

PCN: _____

Supercedes PCN: _____

Date 03-10-06

- 4.1.4 All breathers shall be replaced with airtight seals, plugs or gasketed plates. No venting is recommended as it may allow moist air in.
- 4.1.5 Remove the wiper box seals and cap/plug the seal opening.
- 4.1.6 Clean the pump outer surfaces prior to painting.
- 4.1.7 If painting is required mask crank and lubricator shaft surfaces and keyways. If painting does not apply, go to Para. 4.1.9.
- 4.1.8 Paint as specified by the customer order or as required.
- 4.1.9 Apply a thin layer of grease to the exposed oil seal lips.
- 4.1.10 Apply a thin layer of heavy rust preventative to the exposed crank and lubricator shaft surfaces and keyways.
- 4.1.11 Wrap the exposed crank and lubricator shafts with waxed tape.
- 4.1.12 Carefully wrap the following parts prior to placing them into polyurethane bags. Oil level gages, lube pressure gages, and breather caps.
- 4.1.13 Finish box, crate and mark the parts from Para. 4.1.10 after final inspection (see Para. 4.2.2).

4.2 Shipping/Receiving (New Pumps Only)

- 4.2.1 All pumps and accessories (as applicable) will be final inspected by Kerr Pump personnel prior to shipping. Any witnessed or third party inspection will be signed-off by the purchaser or customer representative prior to final crating and shipment.
- 4.2.2 Export crating will be performed by either an approved Kerr Pump source or as specified by the purchaser or customer. Any third party inspection will be coordinated with the source.
- 4.2.3 Upon receipt of the shipment, the purchaser or customer is responsible for inspection and repair of damaged coatings at the expense of the shipper.

5.0 WARRANTY / START-UP

- 5.1 Pumps prepared per the above procedure qualify for the "Standard Terms & Conditions" in force on the date of shipment.
- 5.2 If the pump storage period will exceed 6 months, follow the Long-Term Pump Preparation Procedure.
- 5.3 Prior to start-up:
 - 5.3.1 Remove all storage caps, plugs, and covers.
 - 5.3.2 Install packing, junk rings, plungers, pony rods (if applicable), baffle discs, and wiper box seals. Replace any damaged or cracked O-rings or gaskets.
 - 5.3.3 Inspect power end shaft oil seals and replace if cracked, split or damaged.
 - 5.3.4 Install crankcase drain plug, lubrication level site glass and breather cap.
 - 5.3.5 Install, if applicable, any oil pressure and/or temperature gage.
 - 5.3.6 Check the connection of the plunger and pony rod to the crosshead prior to, and after, initial run-in of the pump.
 - 5.3.7 Fill the crankcase to the proper level with the specified lubricant.

BUCKHORN
PUMPS, INC.

Kerr Pump Maintenance Schedule for Piston Type Pumps	Daily	Weekly	Monthly	Quarterly	Semi-Annual	Yearly
	or 8 Hrs	or 40 Hrs	or 200 Hrs	or 500 Hrs	or 1000 Hrs	or 2000 Hrs
Check Oil Level in Pump	Visual Inspection	Visual Inspection	Service			
Check Oil Level in Planetary Gear	Visual Inspection	Visual Inspection	Service			
Check for Water or Bentonite in Gear Box	Visual Inspection	Visual Inspection	Visual Inspection	Visual Inspection	Visual Inspection	Visual Inspection
Check Piston Chamber for Leaking Pistons	Visual Inspection	Visual Inspection	Visual Inspection	Visual Inspection	Visual Inspection	Visual Inspection
Check Recovery Tank for Bentonite	Visual Inspection	Visual Inspection	Service			
Check Piston Cooling Pump for Proper Operation	Visual Inspection	Visual Inspection	Visual Inspection	Visual Inspection	Visual Inspection	Visual Inspection
Flush Fluid End	Service	Service	Service	Service	Service	Service
Check Pony Rod Seals	Visual Inspection	Visual Inspection	Visual Inspection	Visual Inspection	Service	
Check and Replace if Necessary Piston Cups		Visual Inspection	Visual Inspection	Visual Inspection	Service	
Check and Replace if Necessary Valve Inserts		Visual Inspection	Visual Inspection	Visual Inspection	Service	
Check and Replace if Necessary Valves and Seats		Visual Inspection	Visual Inspection	Visual Inspection	Service	
Check and Replace if Necessary Liners		Visual Inspection	Visual Inspection	Visual Inspection	Service	
Check Rod Bearings			Visual Inspection	Visual Inspection	Visual Inspection	Service
Check Pony Rods	Visual Inspection	Visual Inspection	Visual Inspection	Visual Inspection	Visual Inspection	Visual Inspection
Check Belts	Visual Inspection	Visual Inspection	Visual Inspection	Visual Inspection	Visual Inspection	Service

BUCKHORN
PUMPS, INC.

WING GUIDED VALVE REPLACEMENT INSTRUCTIONS



1.) Remove the nuts/cap screws from the top cover.



2.A) Remove the top cover and discharge spring.
2.B) Inspect the o-ring for damage.



3.) Remove the discharge valve.

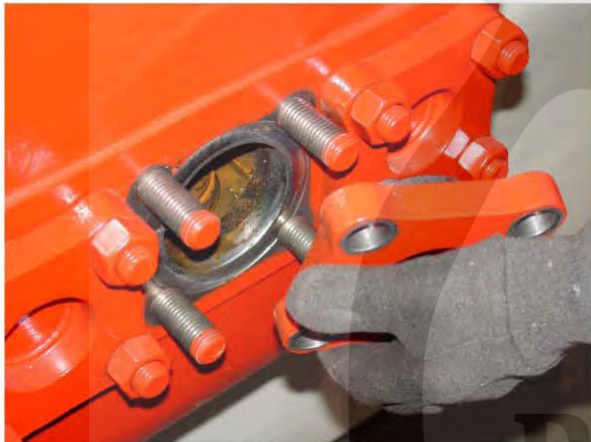

4.A) Remove the end cover cap and suction spring.
4.B) Inspect the valve spring for damage.



5.) Remove the suction valve.



6.) Insert the tri-pin puller head, all pins retracted, into the discharge seat.

BUCKHORN
PUMPS, INC.



7.) Slide puller plate, spacer and washers down the puller rod.



8.) Turn the puller rod until the pins are fully extended.



9.) Lifting the puller rod, turn the nut until firmly in contact with the washers.



10.) Holding the top of the puller rod in place, tighten the nut until the seat releases.



11.) Remove the puller assembly with seat attached.



12.) Loosen the puller rod to retract the pins and remove the seat.

»

Repeat steps 6 thru 12 for suction valve.

**BUCKHORN
PUMPS, INC.**



13.) Install the suction seat and valve. Drive in firmly using bar and hammer.



14.) Install the discharge seat and valve. Drive in firmly using bar and hammer.



15.) Install the suction spring.

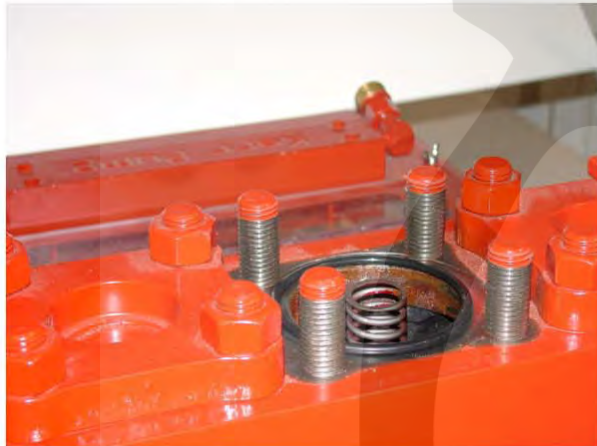

16.) Install the discharge spring.



17.) Tighten all bolts/nuts to specified torque from chart.

BUCKHORN
PUMPS, INC.

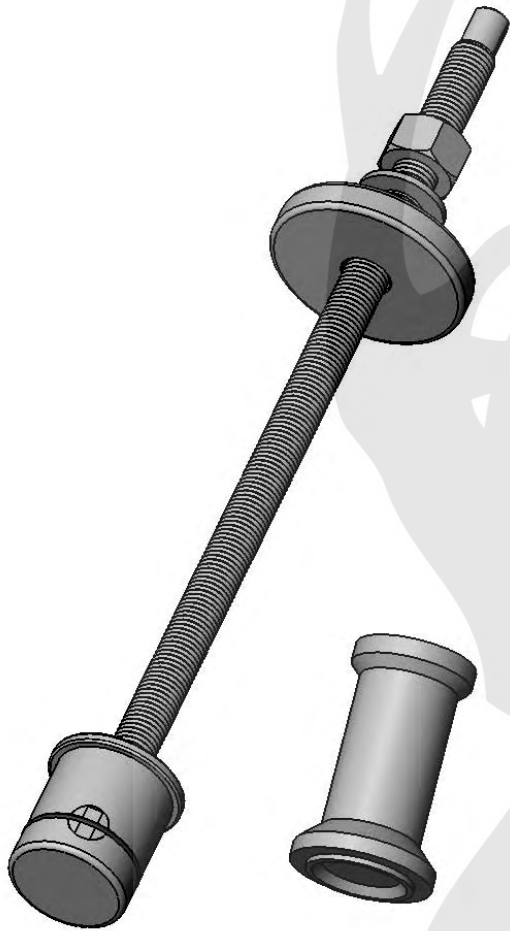

*KA-68M
WING-
GUIDED
SEAT
TRI-PIN
TYPE
PULLER
ASS'Y

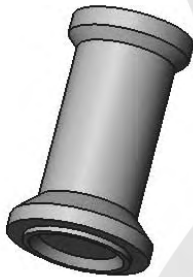

KA-29SG-3
SEAL
GUARD
WIPER
DRIVER

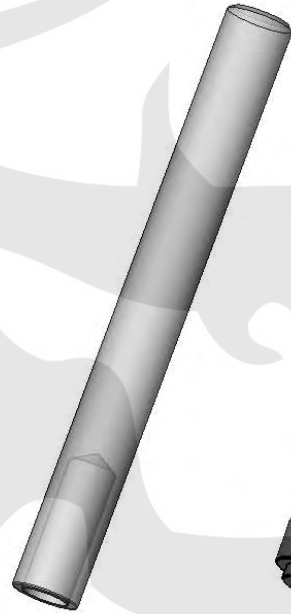

*KA-306
VALVE
SEAT
SEATING
TOOL



*KA-276
PONY ROD
SEAL TOOL



*AP-77T
VALVE
INSERT
TOOL

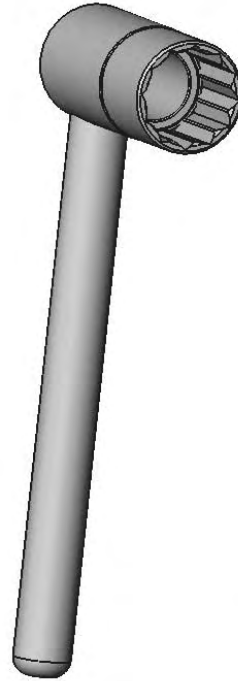

*KA-277
PONY
ROD
WRENCH

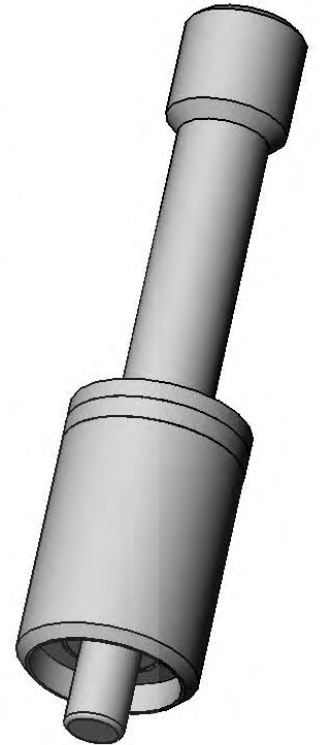

*KA-248
PISTON
SNAP
RING

*INCLUDED IN TOOL KIT P/N KA-900

SPECIAL TOOLS
FOR Q5450PT, KA-3500PT, KT-3350PT, & KT-3400PT

BUCKHORN
PUMPS, INC.

**CRITICAL NOTE:
MATCH GROOVE
& KEEP PIECES TOGETHER
DO NOT MIX WITH
ANOTHER KA-280-A**

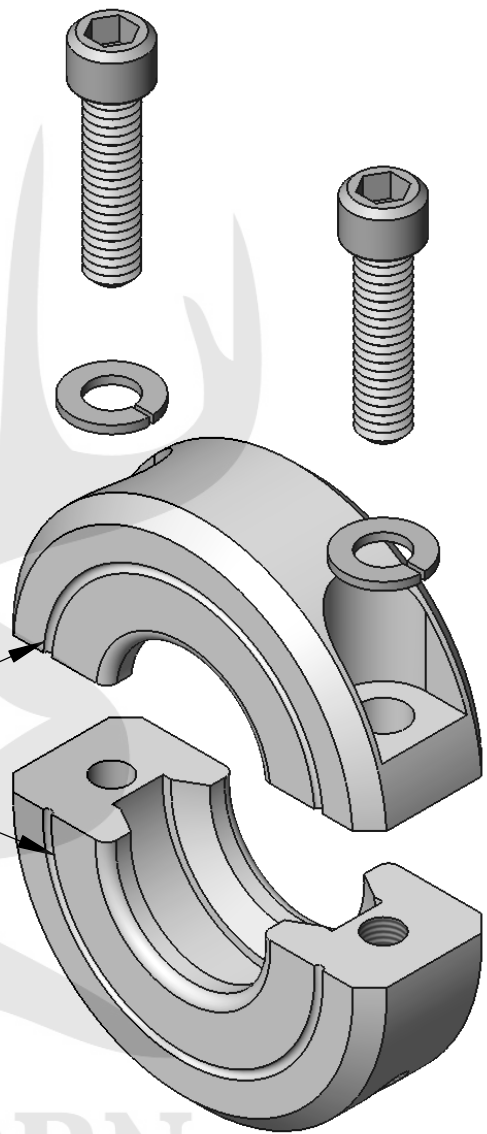

**BUCKHORN
KA-280-A
PUMPS, INC.**

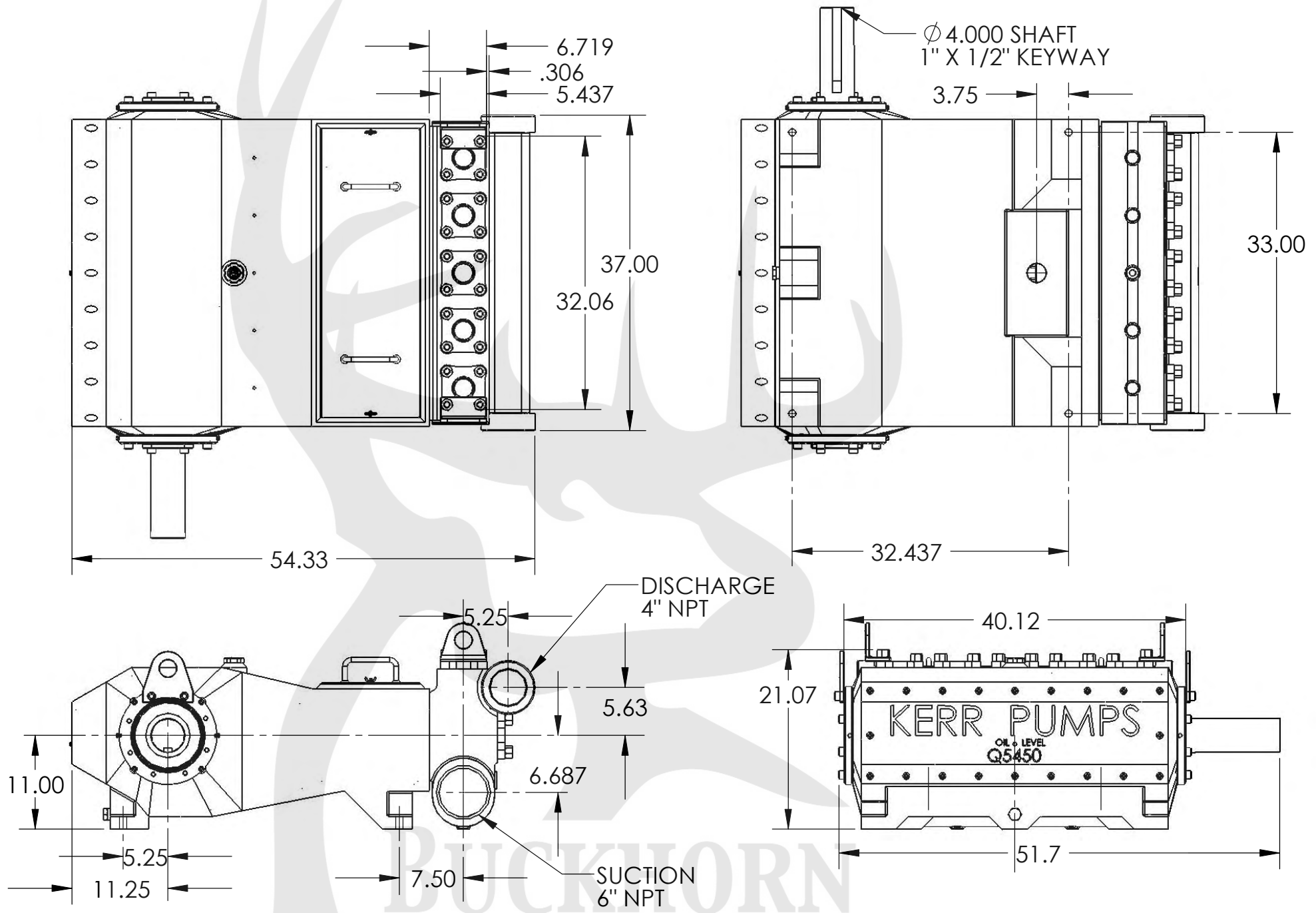

Q5450PT GENERAL DIMENSIONS

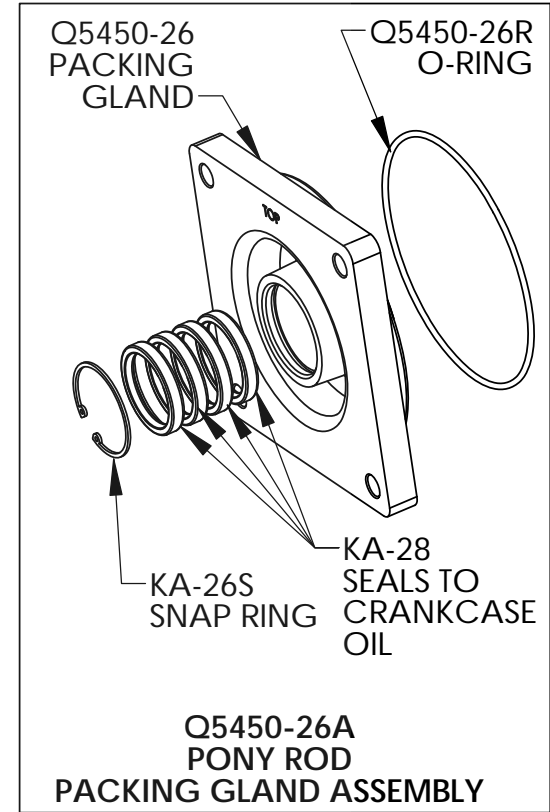
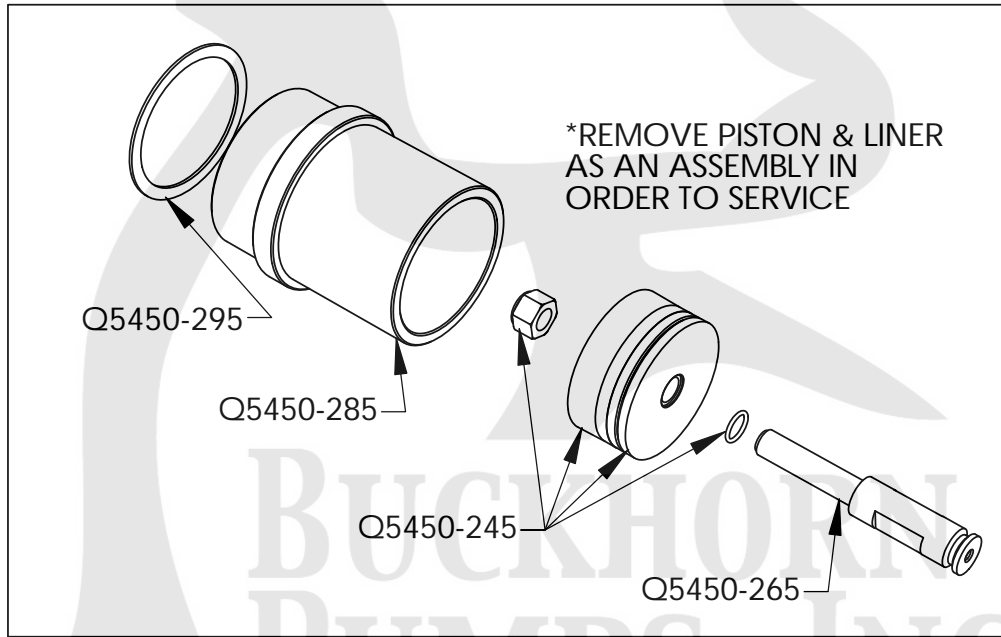
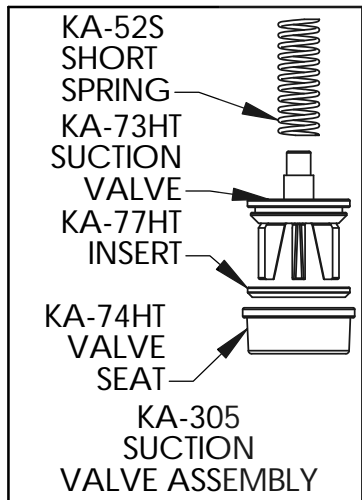
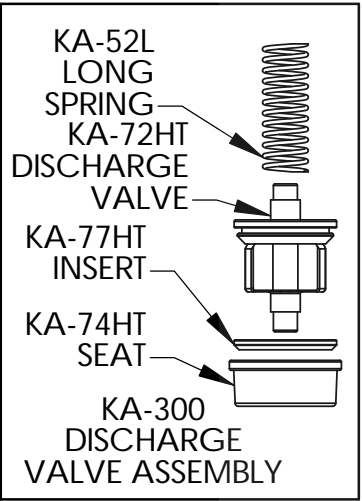
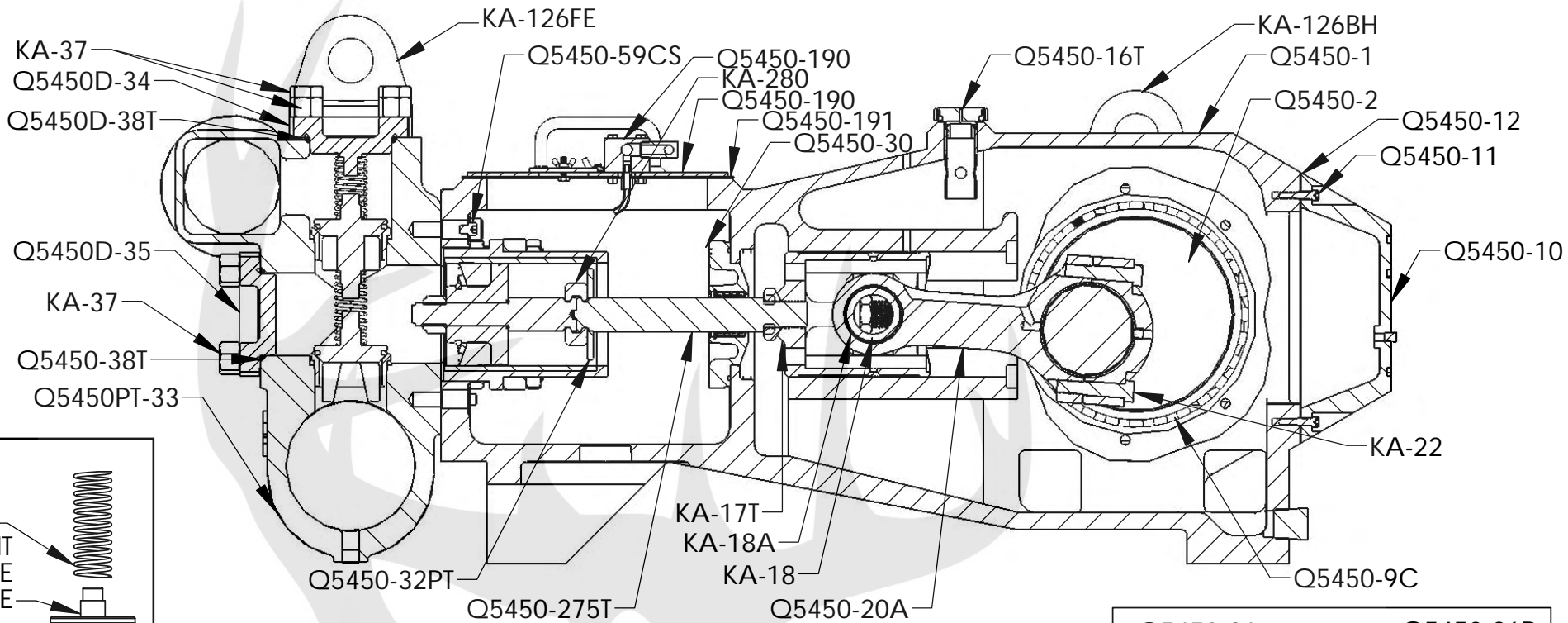

Q5450PT PARTS ILLUSTRATION

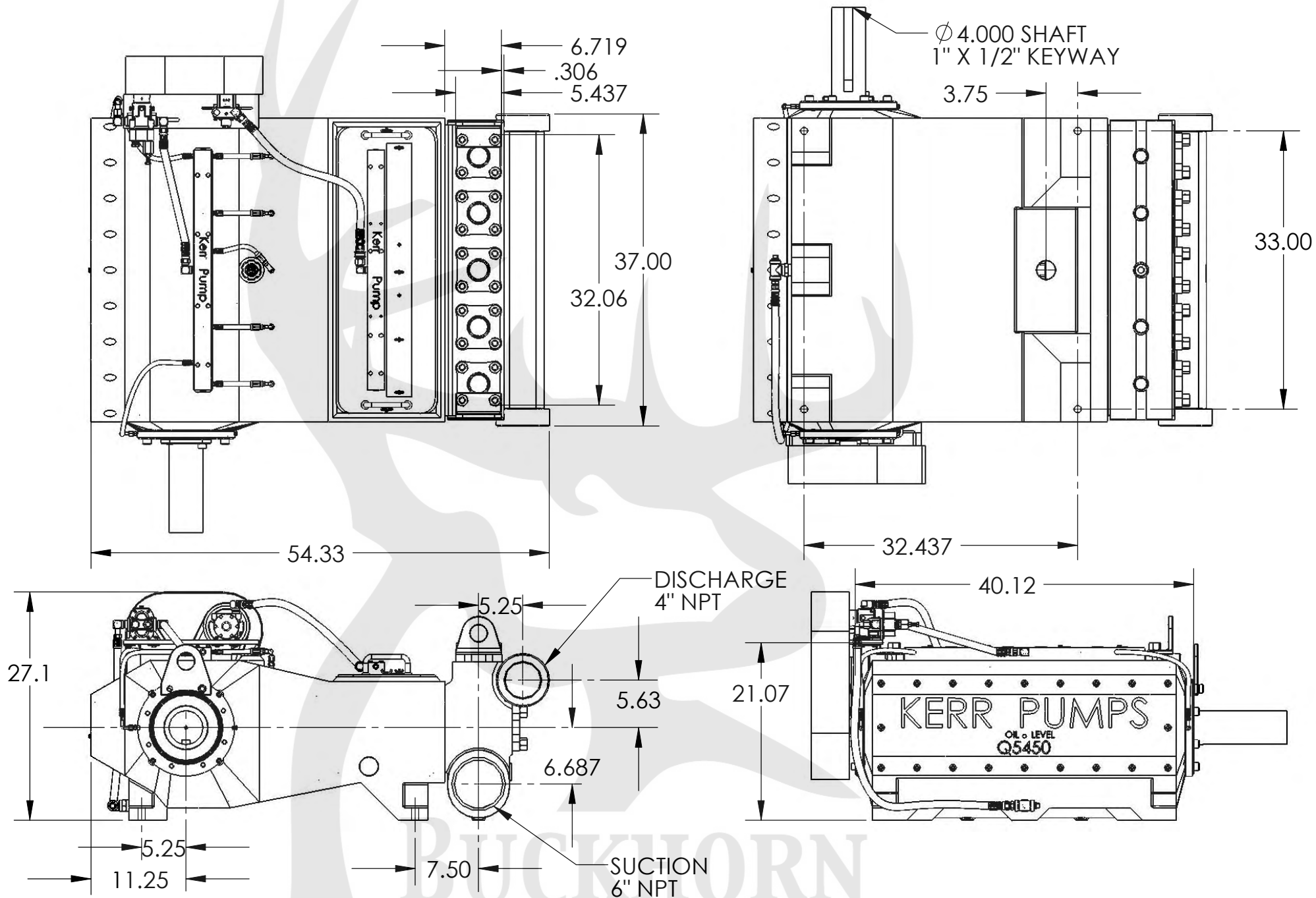

Q5450PT - RH GENERAL DIMENSIONS

TORQUE SPECIFICATIONS FOR Q5450DPT

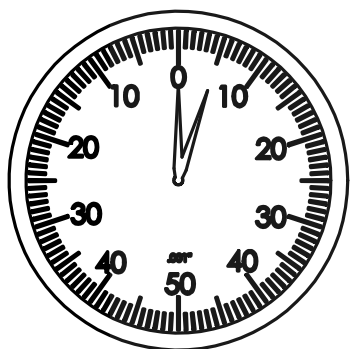
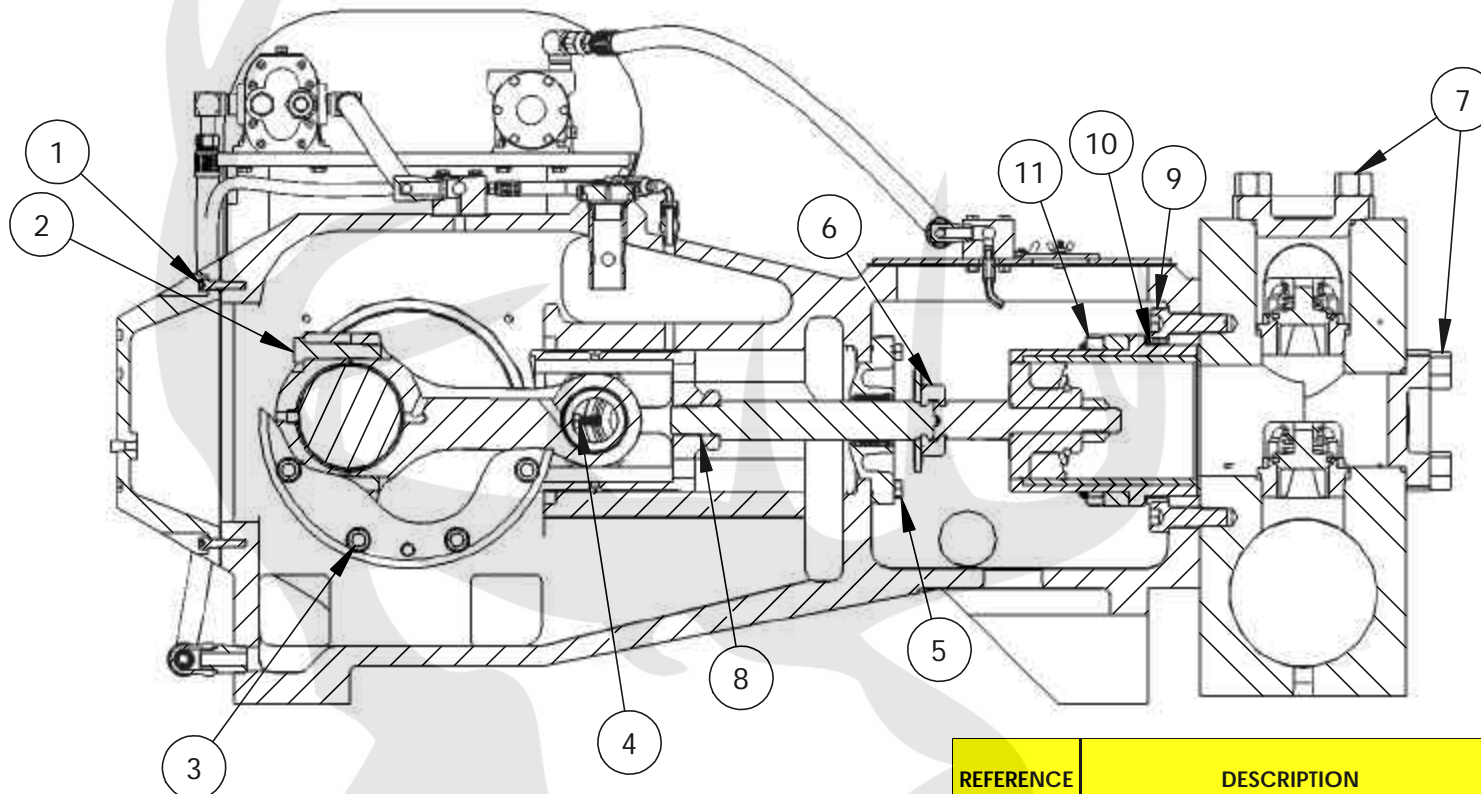

.000" - .005"
SHAFT END PLAY

WHEN ADJUSTING THE ENDPLAY OF THE TAPERED ROLLER BEARINGS USED ON THE CRANKSHAFT, DIAL INDICATORS AND SHIMS MUST BE PROPERLY USED. INCORRECT BEARING ADJUSTMENT MAY RESULT IN EXCESSIVE NOISE, TEMPERATURE, AND REDUCED BEARING LIFE. Kerr Pumps RECOMMENDS BETWEEN .000" - .005" OF INTERNAL AXIAL CLEARANCE (END PLAY) WHEN ASSEMBLED. FINAL ADJUSTMENT MUST BE MADE USING A DIAL INDICATOR.

INSURE THE CONNECTING RODS ARE DISCONNECTED TO ALLOW FREE CRANKSHAFT MOTION.

REFERENCE	DESCRIPTION	TORQUE
1	PAN COVER CAPSCREW	21 ft-lb (28 Nm)
2	CONNECTING ROD CAPSCREW	160 ft-lb (217 Nm)
3	BEARING HOUSING CAPSCREW	75 ft-lb (102 Nm)
4	WRIST PIN SET SCREW AND JAM NUT	30 ft-lb (41 Nm)
5	PONY ROD PACKING GLAND CAPSCREW	50 ft-lb (68 Nm)
6	CLAMP SOCKET HEAD CAPSCREW	20 ft-lb (27 Nm)
7	COVER CAP STUD NUT	900 ft-lb (1220 Nm)
8	PONY ROD	1000 ft-lb (1356 Nm)
9	CAPSCREW FLUID END/CASE	380 ft-lb (515 Nm)
10	FLUID END STUD NUT	350 ft-lb (475 Nm)
11	LINER RETAINER STUD NUT	300 ft-lb (407 Nm)

NOTE: WHEN USING LUBRICANTS, REDUCE TORQUE AS FOLLOWS;

LUBRICANT	PERCENTAGE OF TORQUE REDUCTION REQUIRED
WHITE LEAD	REDUCE TORQUE 25%
GRAPHITE	REDUCE TORQUE 30%
OIL	REDUCE TORQUE 40%
GREASE	REDUCE TORQUE 40%
ANTI - SEIZE COMPOUND	REDUCE TORQUE 45%

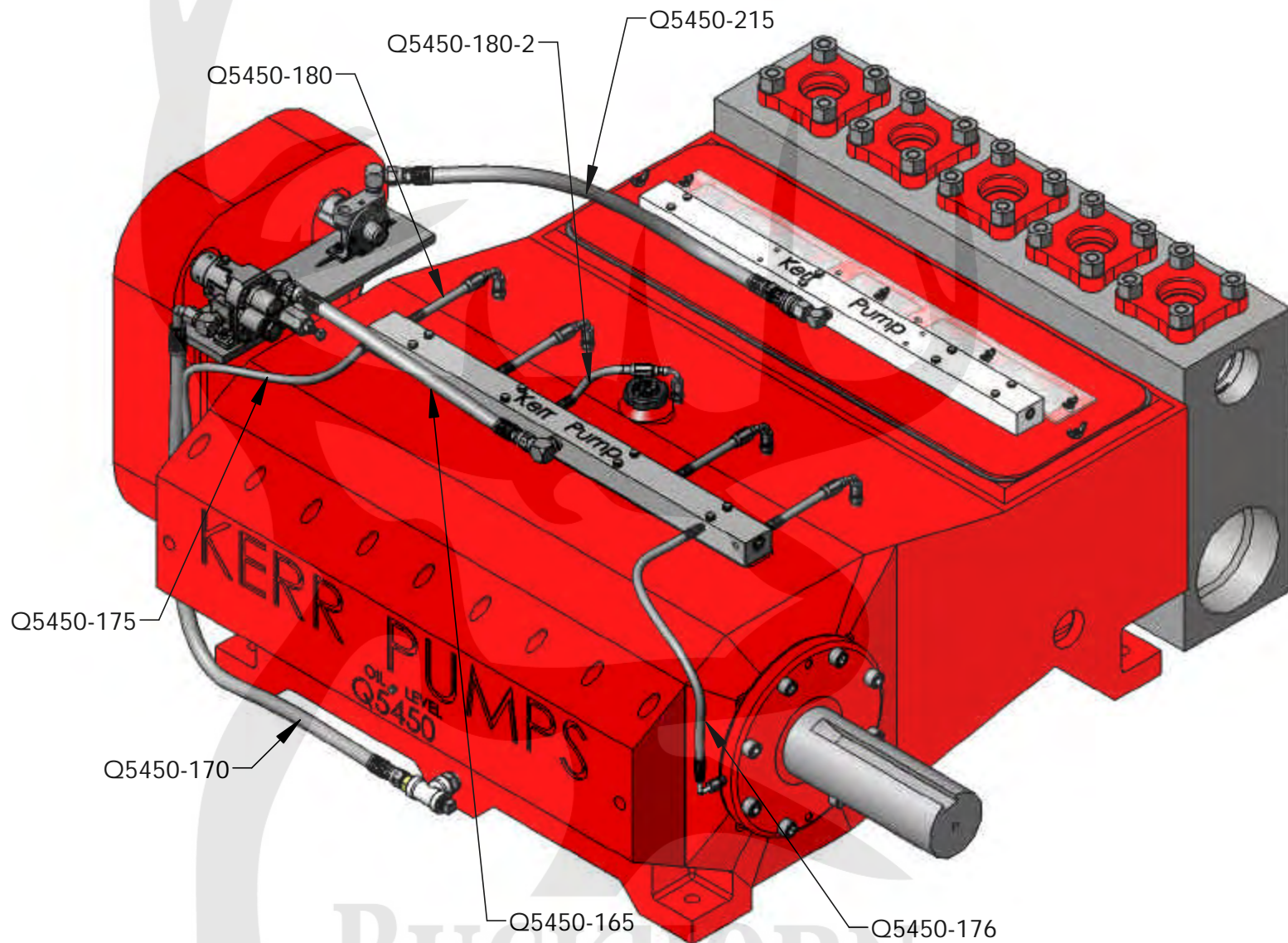

HOSE PART NUMBERS

Q5450PT - RH

BUCKHORN
PUMPS, INC.

Kerr Q5450PT Piston Type Pump

Part Number	Description	# Req
Q5450-1PT	Case, Pump	1
Q5450-2TP	Crankshaft, Heat Treated	1
Q5450-2	Crankshaft, Heat Treated	1
KA-3	Crankshaft Oil Seal	2
Q5450-4	Bearing Housing, Blind Side	1
Q5450-5GS5A	Bearing Housing, SAI Hyd Mtr Shaft Side	1
Q5450-5	Bearing Housing, Shaft Side	1
KA-7	Bearing Housing Gaskets	2
KA-8-015	Main Bearing Adjusting Shims .015	2
KA-8-010	Main Bearing Adjusting Shims .010	2
KA-8-005	Main Bearing Adjusting Shims .005	2
Q5450-9C	Bearing, Center Main	2
KA-9	Main Bearings	2
Q5450-10	Pan Cover	1
Q5450-11	Capscrew, Pan Cover	20
Q5450-12	Gasket, Pan Cover	1
Q5450-16T	Breather Cap (Oil Filler)	1
KA-17T	Crosshead Tapered	5
KA-18A	Wrist Pin Bushing	5
KA-18	Wrist Pin	5
KA-19	Wrist Pin Set Screws & Nut	5
Q5450-20A	Connecting Rod ~ Inserted Both Ends	5
Q5450-20	Connecting Rod ~ without Inserts	5
Q5450-21-030	Connecting Rod Insert Bearing (.030)	5
Q5450-21-015	Connecting Rod Insert Bearing (.015)	5
Q5450-21-000	Connecting Rod Insert Bearing (Std)	5
KA-22	Connecting Rod Capscrew	10
KA-26S	Pony Rod Gland Snap Ring	5
Q5450-26R	O-Ring, Pony Rod Gland	5
Q5450-26A	Gland Ass'y, Pony Rod (Pony Rod Gland, Snap Ring, Seals)	5
Q5450-26	Gland, Pony Rod, Snap Ring Type	5
KA-28	Pony Rod Seal (4 Seals per Set)	5 sets
KA-29SG-3	Installation Tool, Seal Guard Wiper Driver	1
KA-30	Pony Rod Gland Capscrews SS	20
Q5450PT-32	Pony Rod Splash Guard	5

BLACKHORN
PUMPS, INC.

Kerr Q5450PT Piston Type Pump

Part Number	Description	# Req
Q5450PT-33C	PT Fluid End Casted	1
Q5450D-34	Cover Cap, Top, Ductile Iron	5
Q5450D-35	Cover Cap, End, Ductile Iron	5
KA-36	Cover Cap Stud	36
KA-36B	Cover Cap Bracket Stud	4
KA-37	Cover Cap Stud Nut	40
Q5450D-38	O-Ring, Top Cover Cap	10
KA-42-3	Spring, Disc Valve, Inner	5
KA-52L	Valve Spring (Discharge) (Long)	5
Q5450-59CS	Capscrew, Fluid End	10
Q5450-59PT	Stud, Liner Retainer	20
Q5450-60	Nut, Liner Retainer	20
KA-68MH	Valve Puller, Hydraulic, A/R Type Valve	1
KA-68M	Wing-Guided Seat Tri-Pin Type Puller Ass'y	1
AP-71	Drain Plug 1/2" Hex Pipe Plug	1
AP-72S	1/8 NPT Oil Level/Stuffing Box Hex Plug (Steel)	3
KA-72HT	Discharge Valve, Heat Treated A/R with Insert	5
AP-72SS	1/8 NPT Oil Level/Stuffing Box Hex Plug (Stainless Steel)	3
AP-72	1/8 NPT Oil Level/Stuffing Box Hex Plug (AB)	1
KA-73HT	Suction Valve, Heat Treated A/R with Insert	5
KA-74HT	Valve Seat, Heat Treated A/R	5
KA-77R	Discharge Valve Insert Red	5
KA-77HT	Abrasive Resistant Valve Insert (High Temperature)	5
AP-77T	Valve Insert Tool	1
KA-77B	Suction Valve Insert Blue	5
KP-85R	Abrasive Resistant Valve Insert Red	10
Q5450-113PT	Q5450PT Rebuild Gasket Kit Complete Includes the Following Parts: (1) KA-3, (2) KA-7, (1) Q5450-12, (5) Q5450-26R, (5) KA-28, (5) KA-32PT, (10) Q5450D-38, (2)KA-133-1, (3) KA-134-2, (1) Q5450-191, (5) Q5450-246, (5) Q5450-295	1
KA-126FE	Lifting Eye, Fluid End	2
KA-126BH	Lifting Eye, Bearing Cap	2
Q5450-132	Auxiliary Shaft	1
AP-160-5	Fitting, Crosshead Oil Injector	5
AP-160-4	Plug, Oil Manifold	1
Q5450-160	Oil Manifold	1
AP-160-1	Oil Manifold 90 Degree Elbow	1

Kerr Q5450PT Piston Type Pump

Part Number	Description	# Req
Q5450-161	Gasket, Oil Manifold	1
Q5450-165	Oil Line, Pump Manifold	1
Q5450-170	Oil Line, Pump to Oil Sump	1
Q5450-175	Oil Line, Manifold to Bearing Housing	2
Q5450-180	Oil Line, Manifold to Crosshead	5
AP-190-13	Lock Washer, 1/4	4
AP-190-14	Nut, 1/4-20 UNC	4
AP-190-12	Fitting, Water Jet	5
AP-190-11	Piston Chamber Cover Setscrew	2
AP-190-10	Piston Chamber Cover Wing Nut	2
AP-190-9	Piston Chamber Cover Inspection Glass Capscrew	4
AP-190-8	Piston Chamber Cover Inspection Glass Wing Nut	4
Q5450-190A	Piston Chamber Cover Spray Unit Complete	1
Q5450-190	Piston Chamber Cover	1
Q5450-191	Gasket, Piston Chamber Cover	1
Q5450-192	Piston Cover Inspection Glass	2
Q5450-210	Manifold, Water	1
KA-216	Quick Connect, 3/8	1
Q5450-245-450	Piston Complete 4-1/2	5
Q5450-245-425	Piston Complete 4-1/4	5
Q5450-245-400	Piston Complete 4	5
Q5450-245-375	Piston Complete 3-3/4	5
Q5450-245-350MU	Piston Complete 3-1/2 (Molded Urethane)	5
Q5450-245-350	Piston Complete 3-1/2	5
KA-246	Piston O' Ring	5
KA-248	Installation Tool, Piston Snap Ring	1
Q5450-250-450	Piston, Body Only, 4-1/2	5
Q5450-250-425	Piston, Body Only, 4-1/4	5
Q5450-250-400	Piston, Body Only, 4	5
Q5450-250-375	Piston, Body Only, 3-3/4	5
Q5450-250-350	Piston, Body Only, 3-1/2	5
Q5450-260-450	Piston Cup Kit, 4-1/2(Cup, Retainer Plate, Snap Ring)	5
Q5450-260-425	Piston Cup Kit, 4-1/4(Cup, Retainer Plate, Snap Ring)	5
Q5450-260-400	Piston Cup Kit, 4(Cup, Retainer Plate, Snap Ring)	5
Q5450-260-375	Piston Cup Kit, 3-3/4(Cup, Retainer Plate, Snap Ring)	5

BUCKHORN
PUMPS, INC.

Kerr Q5450PT Piston Type Pump

Part Number	Description	# Req
Q5450-260-350	Piston Cup Kit, 3-1/2(Cup, Retainer Plate, Snap Ring)	5
Q5450-265	Extension Rod, Piston Type	5
KA-270	Piston Extension Rod Lock Nut	5
Q5450-275	Pony Rod, Clamp Type	5
KA-276	Installation Tool for Pony Rod Seal	1
KA-277	Installation Wrench, Pony Rod	1
KA-280	Clamp, Pony Rod to Piston Rod	5
KA-281	Capscrew, Pony Rod Clamp ~ Also Used in Q5450-132 Extension Shaft	10
KA-282	Washer, Pony Rod Capscrew ~ Also Used in Q5450-132 Extension Shaft	10
Q5450-285-450CER-A	Ceramic Liner Ass'y, 4-1/2 (Piston Complete, Piston Rod, Lock-Nut, Liner, Liner Gasket)	5
Q5450-285-450CH-A	Chrome Liner Ass'y, 4-1/2 (Piston Complete, Piston Rod, Lock-Nut, Liner, Liner Gasket)	5
Q5450-285-425CH-A	Chrome Liner Ass'y, 4-1/4 (Piston Complete, Piston Rod, Lock-Nut, Liner, Liner Gasket)	5
Q5450-285-425CER-A	Ceramic Liner Ass'y, 4-1/4 (Piston Complete, Piston Rod, Lock-Nut, Liner, Liner Gasket)	5
Q5450-285-400CH-A	Chrome Liner Ass'y, 4 (Piston Complete, Piston Rod, Lock-Nut, Liner, Liner Gasket)	5
Q5450-285-425CH	Liner, 4-1/4 Chrome	5
Q5450-285-425CER	Liner, 4-1/4 Ceramic	5
Q5450-285-400CH	Liner, 4 Chrome	5
Q5450-285-400CER	Liner, 4 Ceramic	5
Q5450-285-375CH	Liner, 3 3/4 Chrome	5
Q5450-285-375CER	Liner, 3-3/4 Ceramic	5
Q5450-285-350CH	Liner, 3-1/2 Chrome	5
Q5450-285-350CER	Liner, 3-1/2 Ceramic	5
Q5450-285-450CH	Liner, 4 1/2 Chrome	5
Q5450-285-450CER	Liner, 4 1/2 Ceramic	5
Q5450-285-400CER-A	Ceramic Liner Ass'y, 4 (Piston Complete, Piston Rod, Lock-Nut, Liner, Liner Gasket)	5
Q5450-285-375CH-A	Chrome Liner Ass'y, 3-3/4 (Piston Complete, Piston Rod, Lock-Nut, Liner, Liner Gasket)	5
Q5450-285-375CER-A	Ceramic Liner Ass'y, 3-3/4 (Piston Complete, Piston Rod, Lock-Nut, Liner, Liner Gasket)	5
Q5450-285-350CH-A	Chrome Liner Ass'y, 3-1/2 (Piston Complete, Piston Rod, Lock-Nut, Liner, Liner Gasket)	5
Q5450-285-350CER-A	Ceramic Liner Ass'y, 3-1/2 (Piston Complete, Piston Rod, Lock-Nut, Liner, Liner Gasket)	5
Q5450-290	Retainer, Liner	5
Q5450-295	Gasket, Liner	5
KA-300HT	Discharge Valve Complete, A/R Heat Treated (KA-72HT, KA-74HT & KA-52L)	5
KA-305HT	Suction Valve Complete, A/R Heat Treated (KA-73HT, KA-74HT & KA-52S)	5
AP-306	Valve Seat Seating Tool	1
AP-351	Sight Glass, Oil Level	1

Kerr Q5450PT Piston Type Pump

Part Number	Description	# Req
AP-352	Oil Level Sight Plug	1
AP-425	Wrench, Stuffing Box Nut	1
KA-900	Tool Kit consists of (KA-68M, AP-77T, KA-248, KA-276, KA-277, KA-306)	1

All prices and part numbers are subject to change without prior notice.

