

**OPERATION AND MAINTENANCE MANUAL, Q16 AND Q18  
QUINTUPLEX PUMPS**

Rev	ECN No.	Date	Reviewed By	Approved By	Status
C	5035702	24-JUL-2014	Ruvalcaba, Mario	Herold, John R.	RELEASED

**Summary:**

This is a manual for FMC Q16 and Q18 quintuplex plunger and piston pumps. These pumps have a stroke length of 4" and 4 1/2" respectively. The power rating for the Q16 is 198 HP (148 kilowatts) and the Q18 is 265 HP (198 kilowatts). Refer to part number P512198 for printing information.



**BUCKHORN  
PUMPS, INC.**

## Table of Contents

<b>1.0</b>	<b>Important Safety Instructions .....</b>	<b>6</b>
<b>2.0</b>	<b>Q16 &amp; Q18 Pump Features .....</b>	<b>7</b>
<b>3.0</b>	<b>Storage Instructions .....</b>	<b>8</b>
3.1	Short Term Storage .....	8
3.2	Short Term Storage for Severe Environments .....	8
3.3	Long Term Storage .....	9
3.4	Returning a Stored Pump to Operation .....	9
3.5	Precautions during Freezing Weather .....	9
<b>4.0</b>	<b>Installation Guidelines .....</b>	<b>10</b>
4.1	General Location .....	10
4.2	Mounting Pump to Foundation and Power Source .....	10
4.3	Suction Piping Recommendations .....	11
4.4	Discharge Piping Recommendations .....	12
4.5	Multiple Pump Systems .....	13
<b>5.0</b>	<b>How to Start a Pump .....</b>	<b>13</b>
<b>6.0</b>	<b>Lubrication of Power End .....</b>	<b>15</b>
6.1	Recommended Lubricants .....	15
6.2	Oil Changes .....	15
<b>7.0</b>	<b>Inspection and Preventative Maintenance Chart .....</b>	<b>17</b>
<b>8.0</b>	<b>Estimated Life of Wearing Components .....</b>	<b>18</b>
<b>9.0</b>	<b>Component Parts List .....</b>	<b>19</b>
<b>10.0</b>	<b>Service Procedures .....</b>	<b>23</b>
10.1	Replacing Plunger Packing .....	23
10.2	Removing the Fluid Cylinder .....	27
10.3	Replacing Valves .....	29
10.3.1	Replacing AR Valves .....	30
10.3.1.1	Introduction .....	30
10.3.1.2	Eccentric Discs .....	31
10.3.1.3	Mandrel Type .....	35
10.3.1.4	Threaded Type (AR Valves Only) .....	37
10.3.1.5	Installation of AR Valves .....	38
10.3.1.5.1	Installing Smaller, Factory Torqued AR Valves .....	38
10.3.1.5.2	Installing Larger, Non-Factory Torqued AR Valves .....	39
10.3.2	Replacing Disc Type Valves .....	40
10.3.2.1	Introduction .....	40
10.3.2.2	Valve Puller with Threaded Tools .....	42
10.3.2.3	J Hook Tool .....	45
10.3.2.4	Installation of Disc Valves .....	46
10.4	Servicing the Power End .....	47
10.4.1	Replacing Plunger Rod Oil Seals and Plunger Rods .....	47
10.4.2	Servicing the Connecting Rod Bearings .....	49
10.4.3	Servicing Bearing Housings, Crankshaft, and Crossheads .....	52

**11.0 Fastener Torque Requirements ..... 62**  
**12.0 Critical Clearances ..... 63**  
**13.0 Valve Removal and Installation Tools ..... 64**  
**14.0 Trouble-Shooting Pumps ..... 65**  
**15.0 Ordering Parts ..... 68**  
**16.0 Glossary of Commonly Used Terms ..... 69**  
**17.0 Reference Information ..... 72**  
**18.0 Maintenance Records ..... 73**  
18.1 Maintenance Log Table ..... 73  
18.2 Checklist for Starting a Pump ..... 74



## List of Figures and Pictures

Figure 1: Pump Assembly Features .....	7
Figure 2: Power End Components .....	19
Figure 3: Fluid End Components.....	20
Figure 4: Plunger and Packing Removal .....	26
Figure 5: Fluid Cylinder Removal .....	28
Figure 6: AR Valve Assembly.....	30
Figure 7: Valve Disassembly.....	31
Figure 8: Eccentric Disc in Use .....	32
Figure 9: Removing the seat .....	33
Figure 10: Hydraulic Power used to Remove Valve Seat .....	34
Picture 1: Mandrel Type Tool .....	35
Figure 11: Mandrel Tool in use.....	36
Figure 12: Threaded Tool in use .....	37
Picture 2: Typical Disc Valve Assembly.....	40
Pictures 3 and 4: Three vs. Five Web Valve Seat .....	41
Figure 13: Removing Seat with threaded tool.....	43
Figure 14: Hydraulic Power Used to Remove the Seat.....	44
Figure 15: J Hook being inserted into the valve seat .....	45
Figure 16: J Hook latched into the Valve Seat.....	45
Chart 1: Torque Values for the Fastener .....	46
Figure 17: Oil Seal and Plunger Rod Replacement .....	48
Figure 18: Back Cover Removal .....	49
Figure 19: Rod Bearing and Oil Seal Removal .....	50
Figure 20: Crank Bearing Removal .....	52
Figure 21: Crank Removal .....	54
Picture 5: Locking Screw for Center Bearing .....	55
Figure 22: Center Bearing Puller.....	55
Figure 23: Plunger (Pony) Rod and Crosshead Removal.....	57
Figure 24: Direct Crankshaft Driven Pump Seal.....	61

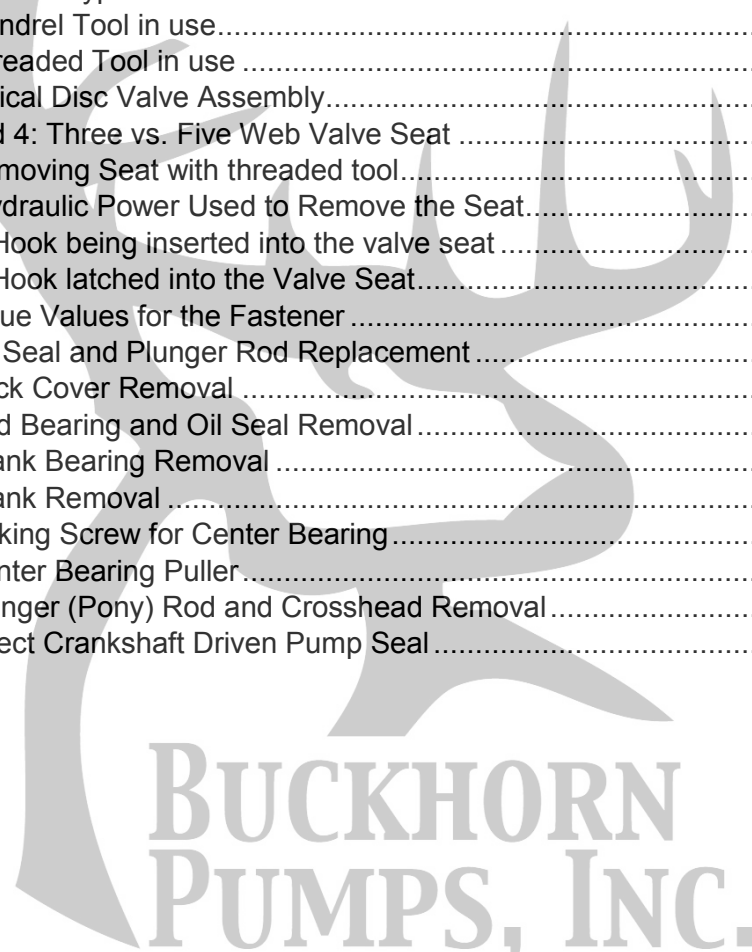

## List of Tables

Table 1: Pipe Pressure Chart.....	12
Table 2: Recommended Drip Lubrication Rates.....	14
Table 3: Lubricant Recommendations.....	16
Table 4: Maintenance Chart.....	17
Table 5: Torque Values for Critical Pump Fasteners.....	63
Table 6: Clearance Chart.....	63
Table 7: AR Valve Removal Tool Guide.....	64
Table 8: Disc Valve Removal Tool Guide.....	64



## 1.0 Important Safety Instructions



**WARNING:**

Many accidents occur every year through careless use of mechanical equipment. You can avoid hazards associated with high pressure equipment by always following the safety precautions listed below.

- **Shut down or disengage** the pump and all accessory equipment before attempting any type of service. Failure to do this could cause electrical shock or injury from moving pump parts or components under high pressure. Always adhere to "Lock Out" and "Tag Out" procedures. For mobile equipment, be sure engines and hydraulics cannot be accidentally started.
- **Bleed off all pressure** to the pump and piping before performing any maintenance on the pump. Failure to do so may spray water or chemicals at high pressure or high temperature onto service personnel.
- **Never operate the pump without a pressure relief valve**, rupture disc, or other type of properly sized over pressure safety device installed.
- **Always use a pressure gage** when operating the pump. The pressure must never exceed the maximum pressure rating of the pump or damage may occur. This damage can cause leakage or structural damage resulting in injury to personnel.
- **Insure that no valves are placed between the pump and pressure relief valve.** If the pump is started with a closed or restricted valve in line before the pressure relief valve, the pump may exceed the rated or design pressure limits and rupture causing injury to personnel.
- **Use shields or covers around pumps** when pumping hot water, chemicals, or other hazardous liquids. This precaution can prevent the exposure of service personnel to these fluids should leakage occur.
- **Always use guards** on all belt drives, couplings, and shafts. Guards can prevent personnel from becoming entangled and injured by rotating and reciprocating parts.
- **Use extreme caution with solvents** used to clean or degrease equipment. Most solvents are highly flammable and toxic. Observe all safety instructions on packaging.
- **follow normal environmental GUIDELINES** when fluids, lubricants, or solvents are disposed of or spilled.
- **NEVER MODIFY THE PUMP** to perform beyond its rated specifications without proper authorization in writing from FMC.

## 2.0 Q16 & Q18 Pump Features

Exceptional design, workmanship, materials, and over 100 years of pump building experience are features you'll find built into every FMC pump. The "Q" Series pumps are available with abrasion resistant (AR) valves or disc valves.

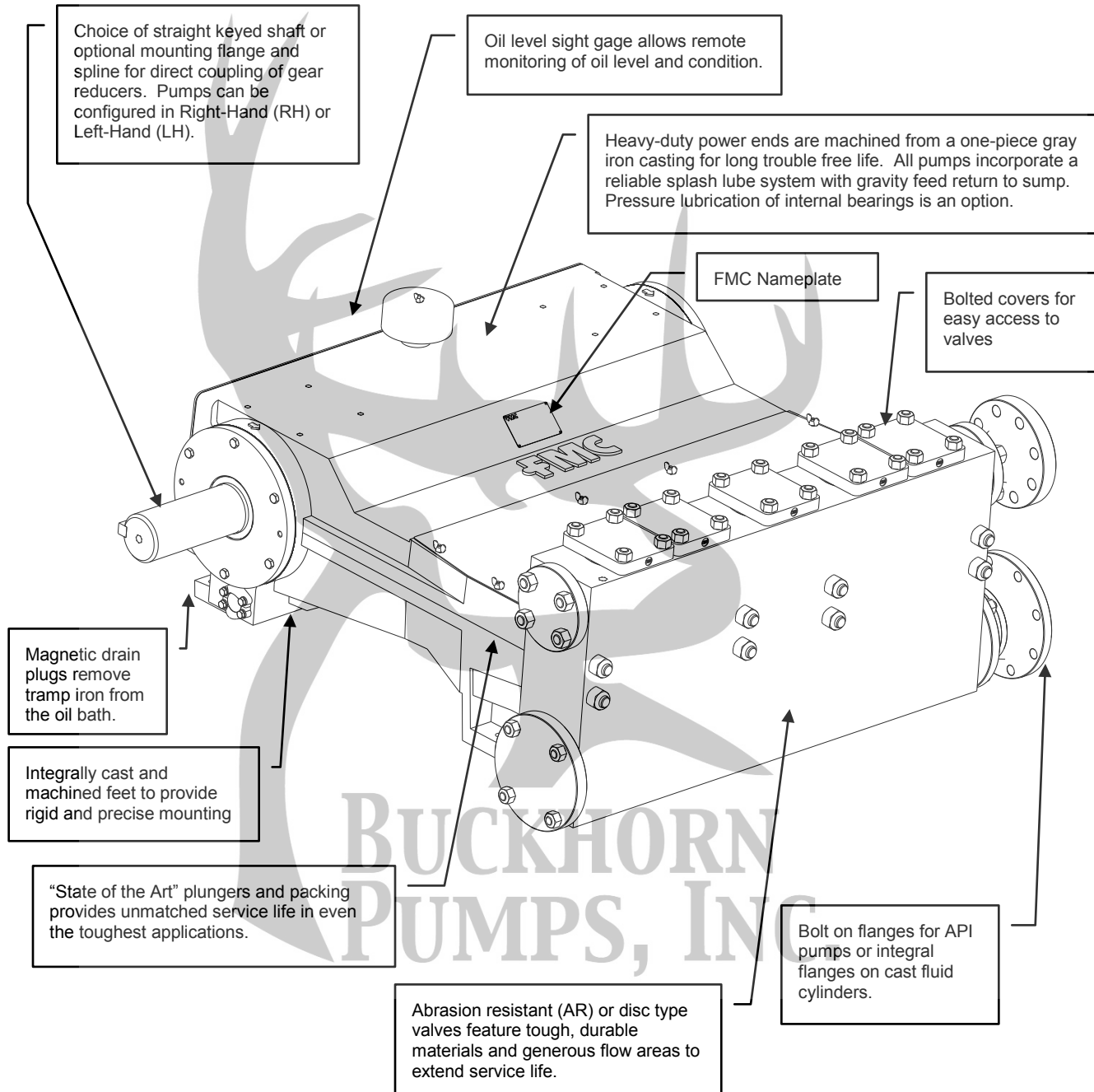

Figure 1: Pump Assembly Features

## 3.0 Storage Instructions

Proper storage of your FMC pump will insure that it is ready for service when started. Follow the guidelines below that fit the requirements of your application.

FMC pumps come from the factory **without crankcase oil** and are prepared for storage periods of up to six (6) months in proper environmental conditions. Indoor storage in a dry, temperature-controlled location is always recommended. If pumps are to be stored short term (less than six (6) months) in a severe environment, they should be prepared using the procedures outlined in the "Short Term Storage for Severe Environments" section 3.2 below. If the pump is to be stored, or is inactive, for periods in excess of six (6) months, it is necessary to prepare the pump as outlined in the "Long Term Storage" Section 3.3. Remember that any fluid that poses an environmental hazard or is toxic must be handled and disposed of properly.

### 3.1 Short Term Storage

If the pump is stored in an indoor, temperature controlled environment for less than six (6) months, no special steps are required to prepare it for storage. As a general rule for pumps in corrosive fluid applications, the fluid end should be drained, flushed with water or other non-corrosive cleanser and compressed air used to blow dry whenever idle.

### 3.2 Short Term Storage for Severe Environments

If the pump has been in service, drain any fluid from pump fluid end by removing the plugs on the bottom of the fluid cylinder, flush the fluid end with water to clean out any of the remaining pumpage and blow dry with compressed air. Drain the power end (crankcase) oil and remove the oil fill cap (or plug). Pour 4 quarts of internal rust inhibitor oil described in Table 3 (see Recommended Lubricant Chart, Section 6.0), into the suction and discharge ports of fluid end, and then install blind flanges or pipe plugs in openings.

Drain the power end (crankcase) oil and remove the oil fill cap (or plug). Pour 4 quarts of internal rust inhibitor oil described in Table 3, into the oil fill hole and then install the filler cap.

Coat all exposed, unpainted metal surfaces (for example, exposed part of driveshaft) with preservative oil. Replace the oil fill cap, and then cover the entire pump with a weather resistant covering such as a canvas or plastic tarp.



### 3.3 Long Term Storage

Long-term storage is defined as any period when the pump is in storage or idle in excess of six (6) months. If the pump has been in service, drain any fluid from the pump fluid end, flush the fluid end with water to clean out any of the remaining pumpage, and blow dry using compressed air. Pour internal rust inhibitor oil described in Table 3, into the suction and discharge ports of fluid end, and then install blind flanges or pipe plugs in openings. Use the same quantity as described in Section 3.2 above. If the pump has cup type pistons, remove them, seal them in a bag to protect against ozone, and store them in a separate location with a controlled environment where they are protected from UV exposure.

Drain the oil from the pump power end. Remove the rear cover to expose the drive components. Spray all internal parts with a rust preservative that is soluble in lubricating oil while rotating the driveshaft several turns by hand to insure complete coverage. Replace the rear cover and add 6 to 8 quarts of internal rust inhibitor described in Table 3.

Spray a rust preventative onto all exterior machined surfaces paying attention to any unpainted areas like the crankshaft extension. Remove the oil fill cap and store with the piston cup seals. Cap the breather opening with a plug or other suitable means in order to keep the preservative atmosphere sealed inside the power end.

Never store the pump on the floor or ground. Always place it on a shelf or pallet that is several inches above ground level. Cover the entire pump with a canvas or plastic tarp. Every two months inspect the unit. Rotate the crankshaft by hand at least 4 turns during each inspection. Drain and replace the rust inhibitor after every six (6) months of storage.

### 3.4 Returning a Stored Pump to Operation

Before operating a pump that has been prepared for storage, drain the preservative and lubricating oil mixture from the power end (crankcase). Reinstall the drain plug, breather/filler cap, and any other components that were removed for storage. Once these steps have been completed, follow the normal pump start up procedures outlined in this manual. NOTE: FMC can factory prepare units for long term storage for a nominal fee if specified at the time of order.

### 3.5 Precautions during Freezing Weather

Freezing weather can cause problems for equipment when pumping water-based fluids that expand in volume when changing from a liquid to a frozen solid state. When water is left in a pump fluid end and exposed to freezing temperatures, the expansion of the water as it freezes can rupture the fluid cylinder of the pump and cause equipment damage. Injury may result when starting equipment that has been damaged.

Whenever the pump is stored or idle in conditions that are near or below freezing, any water-based fluids should be removed from the pump. The best way to do this is to run the pump for a few seconds with the suction and discharge lines disconnected or open to atmosphere. This will clear the majority of the fluid from the pumping chamber as well as the suction and discharge manifolds. After the run, blow compressed air through the fluid end to remove all traces of fluid. If possible, remove plugs from the bottom of the fluid cylinder and lift up the suction valve seats to insure that all fluid is drained from the pumping chamber between the suction and discharge valves.

As an alternative to the previous procedure, a compatible antifreeze solution can be circulated through the fluid end. RV antifreeze, propylene glycol, is recommended for this purpose. Remember that any fluid that poses an environmental hazard or is toxic must be handled and disposed of properly.

## 4.0 Installation Guidelines

A proper installation is essential to optimal performance, long service life, and reduced maintenance requirements. Take time to thoroughly plan all aspects of your installation.

### 4.1 General Location

It is important to position the pump on as flat and level a surface as possible to assist the splash oil lubrication system. Whenever possible the pump should be mounted in a clean, dry location with sufficient lighting and adequate space for easy inspection and maintenance. Locate the pump as close to the suction source as possible to allow for the shortest and most direct routing of the inlet piping.

### 4.2 Mounting Pump to Foundation and Power Source

The Q16 and Q18 pumps described in this document must be mounted on a solid foundation in a horizontal position only. Secure the pump to the mounting surface using the four (4) holes provided in the pump base. Use shims to level the pump if necessary to prevent strain and distortion of the pump power frame. Check motor or engine rotation direction to insure that the top of the pump crank shaft rotates toward the pump fluid end when in operation. Rotation arrows are cast into the power frame to show proper rotation direction on the pump.

For units that are V-belt driven, check the alignment of the sheaves after the unit is installed on its permanent mounting. Tighten belts to the proper tension as recommended by the belt manufacturer. Verify that the sheaves are in line and parallel to each other with a straight edge. **CAUTION:** Never operate the pump without the belt guard securely installed.

For direct-coupled or spline-driven units, insure that the shafts are centered and parallel when the driver is mounted to the pump. Follow the coupling manufacturer instructions

for installation procedures and tolerances. **CAUTION:** Never operate the pump without a shaft guard securely installed.

### 4.3 Suction Piping Recommendations

Poor suction piping practices are a very common source of pump problems. To insure proper operation it is very important to follow good design practice in the installation of the suction system before the pump is operated. A small amount of additional planning and investment in the piping system usually provides for better pump performance and longer periods between service requirements. It is difficult to diagnose many pump problems without the aid of a suction pressure gage. For this reason, FMC recommends that a gage always be installed in the suction line directly before it enters the pump.

The suction line from the fluid source to the pump should be as short and direct as possible. Use rigid piping, non-collapsible hose or a combination of both as circumstances require in your installation. The suction pipe size should be at least equal to or one size larger than the pump inlet. For oversized piping use eccentric reducers to minimize the possibility of trapped air pockets in the suction line. Long piping runs, low suction heads, or indirect pipe routing may require even greater oversizing of the suction line for proper operation of the pump. A suction pulsation dampener is recommended to reduce the effects of acceleration head when suction conditions are not optimal. In some cases it may be necessary to install a booster pump in the suction line of the pump to obtain sufficient pressure for the pump to operate successfully.

The suction line must be configured so there are no high spots in the line where air pockets can collect. These pockets may make the pump difficult to prime and cause rough, erratic operation. A drain valve or plug should be installed at the low point of the suction line to allow for draining before freezing conditions or for maintenance.

FMC recommends that all piping be supported independently of the pump. By supporting the piping this way, vibrations are reduced and stress on the pump is kept to a minimum. The use of elbows, nipples, unions, or other fittings should be minimized. Make sure that all joints and connections are airtight. Air leaks reduce the capacity of the pump and can result in cavitation, rough operation, and/or loss of prime. To help isolate mechanical and hydraulic vibrations, FMC recommends the use of flexible pipe couplings or hose connections between the pump and any rigid piping.

Always insure that calculated system Net Positive Suction Head available, NPSHa, exceeds pump Net Positive Suction Head required, NPSHr, by at least 5 feet (1.5 meters) of water for proper operation of the pump. NPSH requirements for each pump model are provided on the product data sheets available through FMC or your authorized FMC reseller. FMC does not recommend using the pump in static lift conditions without prior factory approval.

## 4.4 Discharge Piping Recommendations

- Route the discharge piping in as short and direct a route as possible. Use the same pipe size as the outlet of the pump. In installations where the discharge piping is in excess of 50 feet (15 meters) it is suggested to use the next larger size pipe to minimize friction losses downstream of the pump.

Allowable Working Pressure For Steel Pipe (PSI @ 100F)					
Pipe Size (inches)	Pipe Schedule Number				
	40	80	120	160	XX
1/2	2,300	4,100		7,300	12,300
3/4	2,000	3,500		8,500	10,000
1	2,100	3,500		5,700	9,500
1 1/4	1,800	3,000		4,400	7,900
1 1/2	1,700	2,800		4,500	7,200
2	1,500	2,500		4,600	6,300
2 1/2	1,900	2,800		4,200	6,900
3	1,600	2,600		4,100	6,100
3 1/2	1,500	2,400			5,600
4	1,400	2,300	3,350	4,000	5,300
5	1,300	2,090	2,950	3,850	4,780
6	1,210	2,070	2,850	3,760	4,660
8	1,100	1,870	2,840	3,700	3,560

14.5 psi = 1 Bar

Table 1: Pipe Pressure Chart

**CAUTION:** Always use pipe or hose that is designed for your particular pressure requirements. Inadequate pressure ratings can allow hose or pipe to fail, resulting in equipment damage and possibly personal injury. Normal hose pressure ratings are clearly marked on the outer surface of the hose. Working pressure ratings for steel pipe can be obtained from the manufacturer or from the chart shown in Table 1 above.

- Always use a pressure gage in the pump discharge line. A properly functioning gage mounted at the pump (and before any valves) is required to accurately determine the operating pressure of a pump and to conduct troubleshooting.
- Insure that all piping is supported independently of the pump to reduce vibrations and strain on the pump. Pulsation dampeners on the discharge are recommended to reduce pressure pulsation and resulting vibration. The use of elbows, nipples, unions, or other fittings should be kept to an absolute minimum. Avoid short radius 90° elbows; use two long radius 45° elbows instead. To help isolate mechanical and hydraulic vibrations, FMC recommends the use of flexible pipe couplings or hose connections between the pump and any rigid piping or the use of pulsation dampeners.
- A properly adjusted pressure relief valve or rupture disc must be installed directly downstream of the pump to prevent damage or injuries resulting from over pressure or deadhead conditions. The relief valve discharge line must be as large as the pipe outlet of the relief valve. Never install valves in the relief valve discharge line or between the pump and relief valve. FMC recommends that the discharge be returned to the tank or drain, not back into the pump suction line.

5. It is recommended that a start-up bypass line and valve be installed to allow flow to bypass the relief valve. This allows the pump to start in an unloaded condition (no discharge pressure).

## 4.5 Multiple Pump Systems

Special consideration must be taken to avoid vibration, pulsation, or uneven flow distribution problems when operating multiple reciprocating pumps using common suction and discharge piping headers. It is recommended that the user contact FMC or experienced industry consultants for assistance with the design of the system and pump installation in these situations.

## 5.0 How to Start a Pump

**CAUTION:** Always take special precautions when starting a pump for the first time or after any extended shutdown. **Never assume that someone else has properly prepared the pump and system for operation.** Always check each component of the system prior to every start-up.

The checklist that follows is intended to be a general guide for starting a pump in a typical installation. A copy of the checklist is provided in Section 18.0, Maintenance Records, to allow it to be copied and used at start up or at service intervals. Every installation is different, and each will have different requirements to insure safe and successful operation. **It is the responsibility of the operator to determine the correct start-up procedure for each installation.**

1. Insure that the drain plug(s) on the bottom of the pump crankcase have been installed and are tight.
2. Check the oil level to insure that the pump is properly filled with non-detergent motor oil or synthetic oil as described in Table 3 and that the oil has not been contaminated with water or other contaminants.

**NOTE:** FMC pumps are shipped with no oil and must be filled to the proper level with the proper grade of non-detergent motor oil or synthetic oil prior to start-up. Use the Table 3 provided in Section 6.0 for selecting the correct oil for your service.

- Pump models Q16 and Q18 require a minimum of 16 gallons (60.5 liters) of oil. Approximately one gallon (3.8 liters) of additional oil is recommended on pumps with external power end lubrication.

Notice the oil level in the sight glass after filling. When full the Q16 should have the level 2-3/8 inches (60 mm) up from the bottom of the glass tube. The Q18 should have the level 3 inches (76 mm) up from the bottom of the glass tube when full. **CAUTION: Do not operate the pump if there is no oil in the sight glass.**

3. Check to insure that power is locked out and tagged out. Turn the pump over by hand if possible to insure free, unobstructed operation. Clean the plungers with a soft cloth while rotating the pump by hand.
4. If the FMC pump is supplied with a factory mounted packing lubricator, insure that it is filled to the recommended level. Refer to Table 3 for the recommended packing lubricant. Follow the vendor specifications for filling intervals and maintenance. See Table 2 for the recommended packing lubrication rates. Hand operate each lubricator pump to provide initial lubrication to packing. It may be necessary to "bleed" the lubrication lines from the lubricator to the stuffing boxes.
5. Check the plunger rods to insure that they are free from abrasive particles or debris.
6. Insure that the pressure relief valve and all accessory equipment have been installed and properly adjusted. Verify that all joints are pressure tight.
7. Open the suction line valve to allow fluid to enter pump. Prime the fluid cylinder if necessary on the initial start up or after the system piping has been drained. The valve covers may have to be cracked open to assist with priming. **CAUTION: Do not loosen the valve covers with volatile or hazardous fluids.**
8. Apply 10 to 20 drops of glycerin or mineral oil to each plunger and plunger rod to lubricate the packing and seals.
9. Make sure that all guards are in place and secure. Verify that all personnel are in safe positions and that system conditions are acceptable for operation.
10. The pump is now ready to start. NOTICE: Whenever possible, use a bypass line for the flow to allow the pump to start in an unloaded condition (no discharge pressure). Slowly close the bypass line to bring the pump into full load conditions. Shut down immediately if the flow becomes unsteady, pressure fluctuates, or if unusual sounds or vibrations are noted.
11. Take temperature readings of the power end and stuffing boxes. Do not exceed 170° F (77° C) on power end. Do not exceed 160° F (71° C) on packing unless packing is designed for hot fluid service.

PLUNGER SIZE	Up to 1 1/2	1 1/2 to 2 1/2	2 1/2 to 3 1/2	3 1/2 to 4 1/2	4 1/2 to 5 1/2	5 1/2 to 6 1/2
DROPS PER MINUTE	8 to 10	12 to 14	16 to 18	20 to 22	24 to 26	28 to 30

Table 2: Recommended Drip Lubrication Rates

## 6.0 Lubrication of Power End

### 6.1 Recommended Lubricants

Few factors can influence the life of a pump more than the power end lubricant (oil). Careful selection of the right type of oil for each particular application will help insure optimal performance from an FMC pump.

The intent of this section is to state the general lubrication requirements for FMC pumps. Several products are listed by manufacturer name in Table 3 below in order to aid the customer in locating suitable lubricants. The following listing is not exclusive, nor an endorsement of any particular product or manufacturer. Consult FMC for lubrication recommendations for applications that fall outside of the conditions listed in Table 3.

NOTE: Lubricant temperatures should not exceed 170° F (77° C) for continuous duty or 180° F (82° C) for intermittent duty (less than 8 hours per day) applications. Crankcase temperatures that exceed these limits will cause the lubricant to prematurely "break down". The result will be poor lubrication and failure of power end components.

The user should consider installation of a heating element such as those furnished by Watlow® for cold ambient temperature or a supplemental oil cooler (heat exchanger) for high ambient temperature operation.

### 6.2 Oil Changes

- Oil changes must be carried out after first 100 hours of operation, and subsequently after every 4000 hours or at least every 6 months. These intervals may be modified depending on actual operating conditions.
- Oil should be changed when hot to prevent build up of sludge deposits.
- CAUTION: To avoid the risk of scalding or burns, pay attention to oil and power end temperature during an oil change.
- It is advisable to check oil level daily. If more than 10% of the total capacity has to be added, check for oil leaks.
- Do not mix oils of different types, even if produced by the same manufacturer.
- Never mix mineral and synthetic oils.
- Follow environmental guidelines when changing and disposing of lubricants.

RECOMMENDED LUBRICANT CHART - Q16 AND Q18								
Type of Service	Ambient Temp	Motor Oil Lubricant				Synthetic Lubricant *		
		SAE Grade	ISO Viscosity (cSt@40 C)	SSU Viscosity	Manufacturer Brand Name	SAE Grade	ISO Viscosity (cSt@40 C)	Manufacturer Brand Name
General Service	0 F to 100 F (-18 C to 38 C)	30	100	550	Texaco® Meropa 100	5W-40	87.0@40 14.7@100	Shell® Rotella T6 Synthetic SAE 5W-40
					Shell® Omala 100 Shell® Rotella T SAE 30 Exxon® XD-3 30 wt Mobil® Trans HD-30			NA
High Ambient Temperature Service	100 F to 130 F (38 C to 54 C)	50	220	1165	Texaco® Meropa 220 Shell® Omala 220 Shell® Rotella T SAE 50 Exxon® HD-3 50 wt Mobil® Trans HD-50	NA	222@40 25.7@100	Mobil® SHC 630
Cold Ambient Temperature Service	0 F to -30 F (-18 C to -34 C)	20	68	350	Texaco® Meropa 68 Shell® Omala 68 Shell® Rotella T SAE 20 Exxon® HD-3 20 wt Mobil® Trans HD-20	5W-30  NA	12.0@100  66.0@40 10.3@100	BP® Vanellus E8 ULTRA 5W-30  Mobil® SHC 626
Frequent Start-Stop Operation		40	150	775	Texaco Meropa® 150			
SPECIALTY ITEMS								
Internal Rust Inhibitor					Cortec® VCI 329			
External Rust Preventative					Texaco® Metal Protective Oil L			
Packing Lubricant (Use Rock Drill Oils)					Manufacturer Brand Name			Pour Point (F)
					Exxon® Arox 150 Shell® Toreula 150 Mobil® Almo 529			

\*Synthetic lubricants are suggested for high or low temperature service.

Cortec® is a registered trademark of Cortec Corporation, St. Paul, NM

Table 3: Lubricant Recommendations



## 7.0 Inspection and Preventative Maintenance Chart

Routine maintenance is an essential part of any successful pump installation. Properly maintained FMC pumps are designed to offer years of trouble-free service.

Regular maintenance and inspection will keep your pump operating at peak performance. FMC pumps have been carefully engineered to minimize maintenance requirements and simplify these tasks when they are required. Regular inspections allow operators to become familiar with normal pump operation so they can recognize the signals of potential problems and schedule maintenance. The maintenance chart in Table 4 shown below should be used as a guideline only. Many applications will require adjustment of the intervals shown in this chart for severe or unusual operating conditions.

Interval	Component	Service	Remarks
Break In Period	Crankcase Oil	Change	Drain and refill with new oil after first 100 hours of operation. Insure that the magnetic drain plugs are cleaned to remove debris.
	Inlet Strainer	Inspect	Clean if Required. The amount of material in the strainer will determine the interval of cleaning.
Daily	Complete Pump	Inspect	General inspection of pump and system to check for proper operation of equipment.
	Packing or piston sets	Inspect	Check the plunger and stuffing box area of the pump for signs of leakage. Adjust or replace packing if leakage becomes excessive.
	Pump System	Flush	Required for shutdown when pumping fluids that may harden or corrode the pump if left inside once stopped.
	Crankcase Oil	Inspect	Insure that the oil is at proper level and has not been contaminated by pumpage or condensation.
6 Months/ 4,000 hours	Crankcase Oil	Change	Drain and refill with new oil. Clean magnetic drain plugs.
	Stuffing Box Nuts	Inspect	Check the stuffing box bolts with a torque wrench to insure they are within specification.
	Connecting Rod Bolts	Inspect	Check the connecting rod bolts with a torque wrench to insure they are within specification. This should be done in conjunction with oil change.

Table 4: Maintenance Chart

## 8.0 Estimated Life of Wearing Components

The information given here is an estimate of the average wear life of listed components in clean liquid service. It is not a guarantee of life for any given application, but is intended to facilitate maintenance schedules and stocking of spares. The maintenance of the power end lubrication system will influence the life of the power end components. The speed of operation and percent of maximum allowable load will influence the life of both power end and fluid end parts. The temperature, abrasiveness, and lubricity of the liquid affect the life of fluid end expendables.

POWER END COMPONENT	ESTIMATED LIFE (Hours)
End and Main Bearings (Roller or Ball)	40,000
Wrist Pin Bushings	20,000
Lubrication pump	20,000
Crossheads	20,000
Power End Cover Gasket	10,000
Connecting Rod Bearings	10,000
Crankshaft Oil Seals	10,000
Oil Seal on Plunger (Pony) Rod	5,000
FLUID END COMPONENT	ESTIMATED LIFE (Hours)
Stuffing boxes	16,000
O-Ring Seals	10,000
Valve Assembly	10,000
Plungers	8,000
Packing adapter rings	8,000
Packing	4,000
Ceramic Liners	3,000
Piston Cups	1,500

## 9.0 Component Parts List

A typical pump configuration is shown below for general reference purposes. This will aid in identifying components for service procedures outlined in the following sections. Actual pumps supplied by FMC may use different components or configurations.

To order service parts or see exact component configurations for your particular pump, refer to the cross-section parts drawing in the literature kit supplied with the pump. Contact your local FMC pump distributor or FMC if you do not have this information.

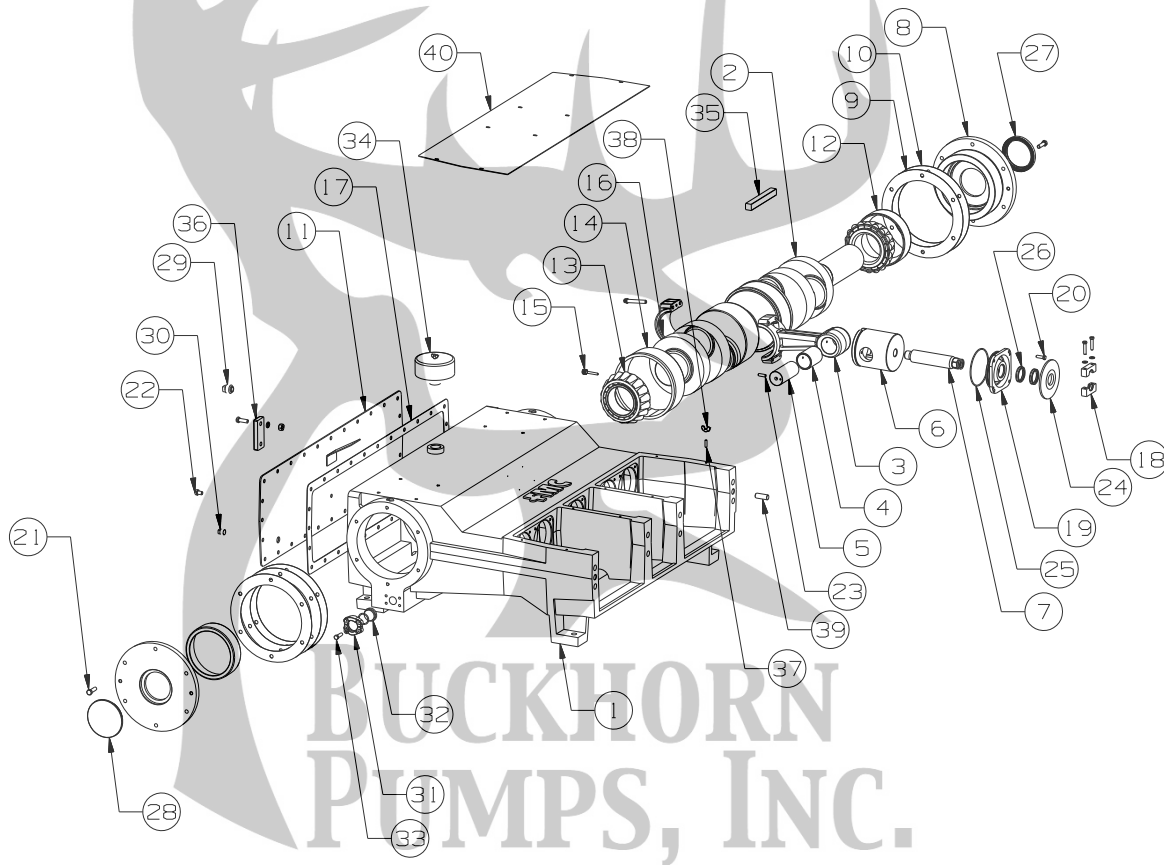

Figure 2: Power End Components

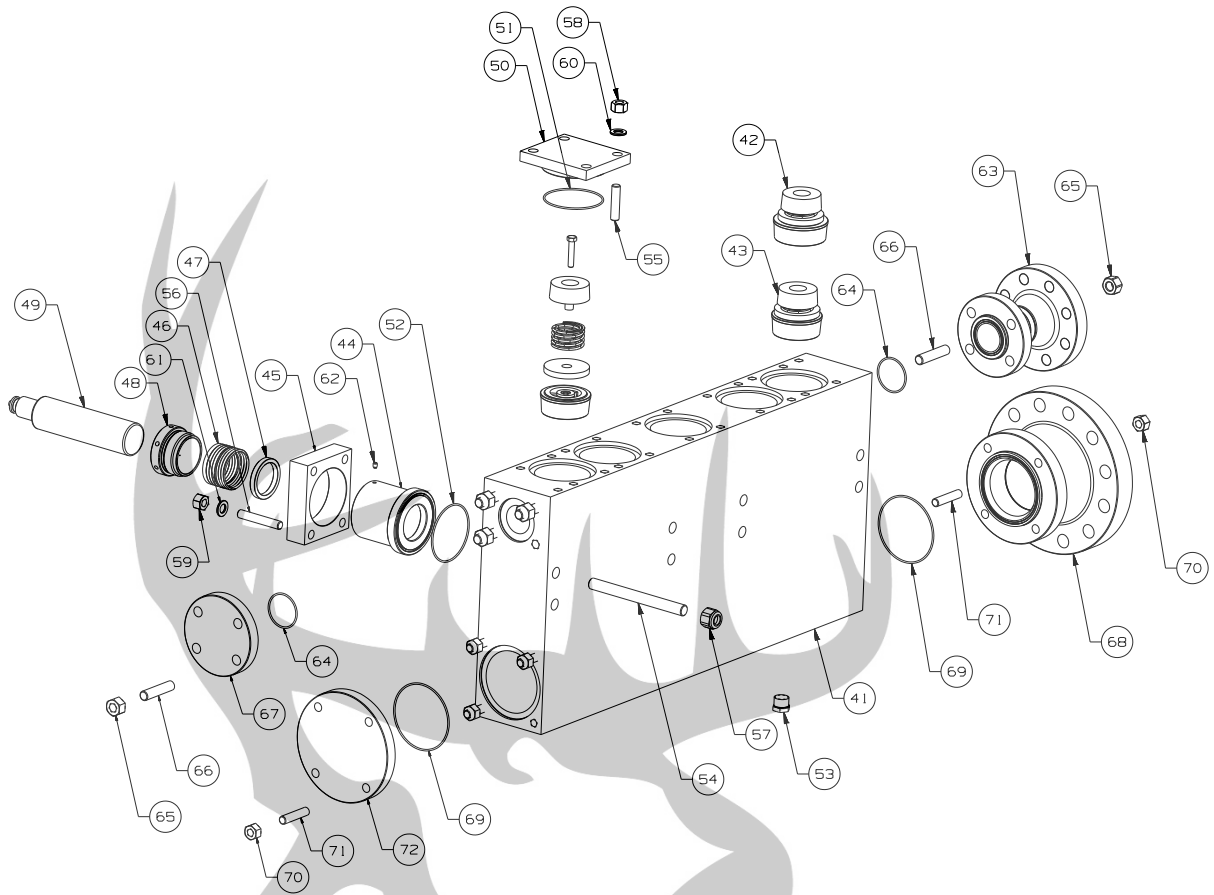

Figure 3: Fluid End Components

The illustrations above depict a typical pump with a forged fluid cylinder, Disc type valves, and standard V-Ring packing. NOTE: Stuffing box and stuffing box clamp may be one part or two separate parts.

The service procedures outlined in this manual are intended to describe the more popular type of pump. Other configurations and minor design differences may exist with alternate pumps. Some procedures may require slight adaptations as a result.

Item Number	Component Description	Quantities for Each Model	
		Q16	Q18
1	Power Frame	1	1
2	Crankshaft	1	1
3	Connecting Rod Assembly	5	5
4	Connecting Rod Bushing	5	5
5	Wrist Pin	5	5
6	Crosshead	5	5
7	Plunger Rod	5	5
8	Bearing Housing	2	2
9	Gasket (Bearing Housing)	2	2
10	Shim	As Needed	As Needed
11	Back Cover	1	1
12	Bearing Cup	2	2
13	Bearing Cone	2	2
14	Center Bearing	2	2
15	Lock Screw (Center Bearing)	2	2
16	Rod Bearing	10	10
17	Back Cover Gasket	1	1
18	Plunger Clamp Assembly	5	5
19	Seal Housing	5	5
20	Cap Screw (Seal Housing)	20	20
21	Cap Screw (Bearing Housing)	12	12
22	Cap Screw (Back Cover)	28	28
23	Set Screw (Cross Head)	5	5
24	Deflector Shield	5	5
25	O-ring (Seal Housing)	5	5
26	Plunger Rod Seal	10	10
27	Crankshaft Oil Seal	1	1
28	Bearing Housing Plug	1	1
29	Magnetic Pipe Plug	1	1
30	Pipe Plug – ½ NPT	2	2
31	Split Flange Assembly	2	2
32	Split Flange Plug	2	2
33	Cap Screw (Split Flange)	8	8
34	Breather Cap	1	1
35	Key	1	1
36	Liquid Level Gage	1	1
37	Stud (Cradle Cover)	8	8
38	Wing Nut	8	8
39	Dowel Pin	2	2
40	Cradle Cover	1	1

Subject to contractual terms and conditions to the contrary, this document and all the information contained herein are the confidential and exclusive property of FMC Technologies, and may not be reproduced, disclosed, or made public in any manner prior to express written authorization by FMCTI.

Item Number	Component Description	Quantities for Each Model	
		Q16	Q18
41	Fluid Cylinder	1	1
42	Discharge Valve Assembly	5	5
43	Suction Valve Assembly	5	5
44	Stuffing Box	5	5
45	Stuffing Box Clamp	5	5
46	Plunger Packing (Set)	5	5
47	Throat Bushing	A/R	A/R
48	Adjusting Nut	5	5
49	Plunger	5	5
50	Valve cover	5	5
51	O-ring (Valve Cover)	5	5
52	O-ring (Stuffing Box)	5	5
53	Pipe Plug (Suction Manifold)	5	5
54	Stud (Fluid Cylinder)	4	4
55	Stud (Valve Cover)	20	20
56	Stud (Stuffing Box Clamp)	20	20
57	Lock Nut	4	4
58	Hex Nut (Valve Cover)	20	20
59	Hex Nut (Stuffing Box Clamp)	20	20
60	Washer (Valve Cover)	20	20
61	Washer (Stuffing Box Clamp)	20	20
62	Set Screw (Nylon Tipped)	5	5
63	Discharge Spool (For flange config)	1 OR 2	1 OR 2
64	O-Ring, Disch. (For flange config)	2	2
65	Hex Nut, Disch. (For flange config)	8	8
66	Stud, Disch. (For flange config)	8	8
67	Blind Flange, Disch.(Flange config)	0 OR 1	0 OR 1
68	Suction Spool (For flange config)	1 OR 2	1 OR 2
69	O-Ring, Suction (For flange config)	2	2
70	Hex Nut, Suction(For flange config)	8	8
71	Stud, Suction (For flange config)	8	8
72	Blind Flange, Suction(Flange config)	0 OR 1	0 OR 1

## 10.0 Service Procedures

FMC pumps are designed to simplify all required maintenance. The following sections illustrate step-by-step instructions for performing most common service procedures of a pump. Read each section before starting service work on the pump.

Refer to Figures 2 and 3 for location of components.

It is recommended that a sufficient quantity of clean water be pumped through the fluid end before starting any service procedures that involve fluid end components. This will remove a significant portion of contaminants left in the fluid cylinder by the normal pumpage and improve the ability to work with parts or see potential problems.



**WARNING:**

Many accidents occur every year through careless use or service of mechanical equipment. You can avoid hazards associated with high-pressure equipment by always following the safety precautions listed in Section 1.0.

### 10.1 Replacing Plunger Packing

**CAUTION: CHECK TO INSURE THAT THE POWER IS LOCKED OUT AND TAGGED OUT (MOTOR OR ENGINE CANNOT BE STARTED).**

1. Bleed off all pressure inside pump fluid end before starting any service work. Shut the valve on the inlet piping, if provided, to prevent flow of liquid from the source into the pump during service work.
2. Refer to Figure 3 or Figure 4 for location of components. Unbolt the plunger clamps (18) and remove them from the plungers (49) and plunger rods (7). Removal Tip 1: If the plunger does not separate from the plunger rod (stuck together), place a wrench extension or rod between the plunger and the power frame. Rotate the crankshaft to move the plunger rod away from the plunger.
3. Loosen the set screw (62) locking the threads on the adjusting nut (48). Turn the adjusting nut counterclockwise to loosen. Use caution if the packing (46) is spring loaded. The adjusting nut will come off suddenly from the stuffing box due to spring force.

4. Remove the nuts (59) holding the stuffing box or stuffing box clamps (45) to the fluid cylinder (41) to allow removal of the stuffing boxes from the fluid cylinder counterbore. Rotate the crankshaft (2) by hand until one of the plunger rods (7) is fully retracted from the plunger (49) and push the plunger forward into the stuffing box to provide adequate clearance for removal. Removal Tip 2: Backing the plunger rod away from the plunger and adding a short rod such as a wrench extension located between the plunger and plunger rod will push the plunger further into the stuffing box and fluid cylinder. It may be necessary to hit the stuffing boxes with a rubber mallet to free them from the counterbores.
5. Slide the plunger and stuffing box out of the cradle of the pump as a single unit. Repeat this procedure for the other four plunger and stuffing box assemblies. Be careful not to lose the o-rings (52) that seal the stuffing box.
6. If possible take the plunger/stuffing box assemblies to a work bench. Pull or hit the plunger with a rubber mallet or hammer handle to remove from the stuffing box assembly.
7. Remove the packing (46) by tapping out with a brass bar or by bumping the stuffing box on the table. Observe the type and orientation of packing components during removal. V-ring orientation, if V packing is installed, is critical to proper operation. The lips of the "V" must face the fluid chamber (41). Braided rope packing requires that the cuts in the rope are staggered at approximately 180° apart at installation.
8. Clean stuffing box bore and junk rings (47) such as throat bushing or lantern ring as required with 60 grit emery cloth and solvent. Clean plungers (49) with steel wool or solvent and a soft cloth. Clean other parts such as springs and adjusting nuts as required with a wire brush.



9. Inspect all parts for excessive wear patterns and replace any components that appear damaged. Insure that the plungers are smooth and free of cracks, scores and grooves. New packing will fail prematurely if used with plungers that have damaged or have rough surfaces (exceeding 16 Ra finish). FMC suggests that all five packing sets be replaced, not just those that show signs of leakage, whenever this type of service is performed. This will help insure maximum operating time between service intervals.
10. Apply oil to the plungers and stuffing box bores. Clean the fluid cylinder counterbores and stuffing box outside diameter that fits into the counterbore. Lightly grease surfaces and o-rings.
11. Reverse the previous steps to rebuild the pump after damaged components have been replaced. FMC suggests that all seals or gaskets that are disturbed during a service procedure be replaced. This includes the stuffing box face seal o-ring (52). Installation Tip: Apply grease around each o-ring before installing in the groove to prevent the o-ring from falling out when installed. Insure that all fasteners are tightened to the values specified in Fastener Torque Requirements, Section 11.0 of this manual.
12. When tightening fasteners on a stuffing box or stuffing box clamp, use crisscross tightening in three stages of torque. Begin at approximately 25% of the final torque value, then 50% of the final torque, and finish at full torque value. CAUTION: Take care to insure the stuffing box and clamp are properly piloted in the fluid cylinder and alignment is correct (stuffing box and plunger are axially aligned to plunger rod and perpendicular to the fluid cylinder mounting surface). The boxes should easily slide into the fluid cylinder counterbore.
13. The plunger tip should slide easily into the recess of the plunger rod if alignment is correct. If it does not, loosen the stuffing box nuts and check alignment of stuffing box to the fluid cylinder.

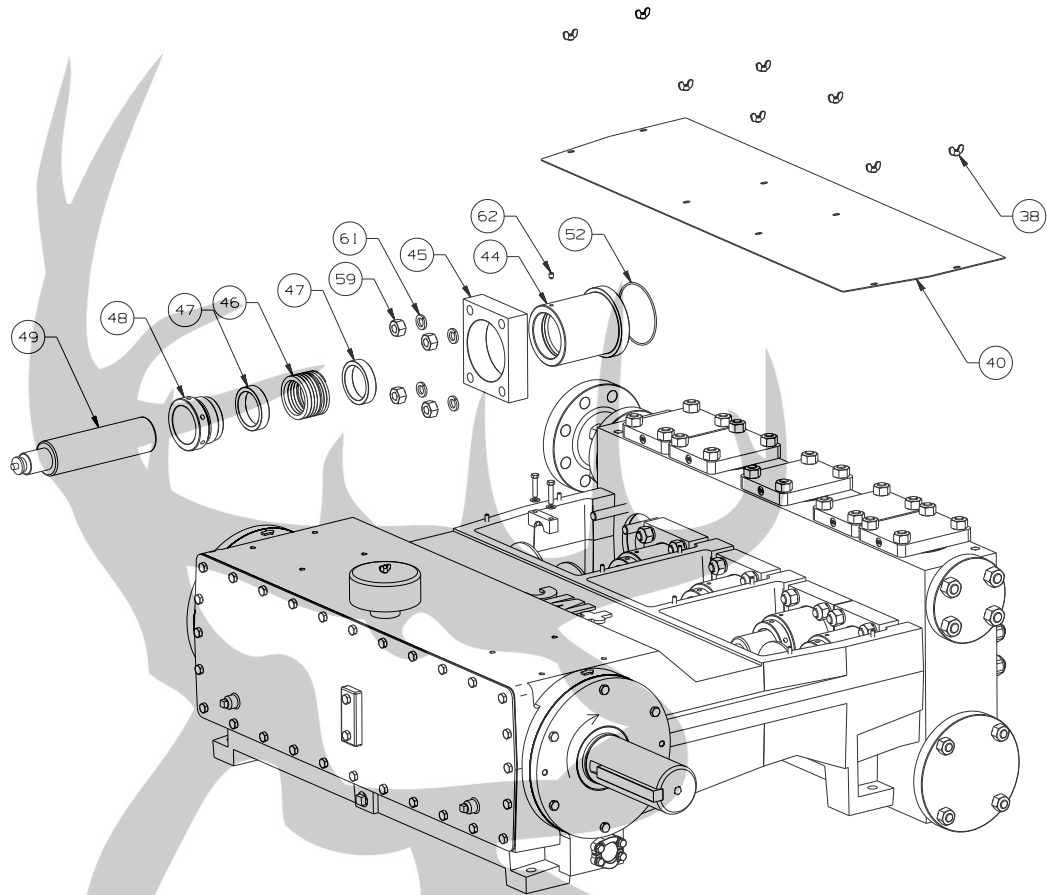

# BUCKHORN PUMPS, INC.

Figure 4: Plunger and Packing Removal

## 10.2 Removing the Fluid Cylinder

NOTE: The fluid cylinder (41) may be removed to inspect for internal damage, to be repaired, or to be replaced.

Refer to Figure 3 and Figure 5 for location of components.

It is recommended that a sufficient quantity of clean water be pumped through the fluid cylinder before starting any service procedures that involve fluid end components. This will remove a significant portion of contaminants left in the fluid cylinder by the normal pumpage and improve the ability to work with parts or see potential problems.

**WARNING:**

Many accidents occur every year through careless use or service of mechanical equipment. You can avoid hazards associated with high-pressure equipment by always following the safety precautions listed in Section 1.0.

**CAUTION: CHECK TO INSURE THAT THE POWER IS LOCKED OUT AND TAGGED OUT.**

1. Bleed off all pressure inside pump fluid end before starting any service work. Shut the valve on the inlet piping if provided to prevent flow of liquid from the source into the pump during service.
2. Unbolt the plunger clamps (18) and remove them from the plungers (49) and plunger rods (7). Slide all of the plungers forward as far as possible. Refer to Section 10.1, paragraph 4 for detailed instructions on sliding the plunger forward.
3. Disconnect the suction and discharge piping.
4. Remove the lock nuts (57) holding the fluid cylinder assembly on to the power frame (1). Support the weight of the fluid cylinder assembly and slide the assembly away from the power frame. CAUTION: Stand clear as the fluid cylinder slides off the studs (54).
5. Disassemble the fluid cylinder assembly as required to inspect or perform service. Refer to the appropriate section for proper disassembly and reassembly procedures.
6. Inspect all parts for signs of wear or damage. Replace parts if required.
7. Reverse the previous steps to rebuild the fluid cylinder assembly after damaged components have been replaced. Make sure that the dowel pins (39) are in good condition and are in place before installing the fluid cylinder assembly. FMC

suggests that all seals or gaskets that are disturbed during a service procedure be replaced.

8. Insure that all fasteners are tightened to the values specified in Fastener Torque Requirements, Section 11.0 of this manual. Use a crisscross tightening pattern in three stages. Tighten to 25%, 50%, and then 100% of the full torque values. Please note that if the nuts (57) on the fluid cylinder studs (54) are not properly torqued, a failure is likely..

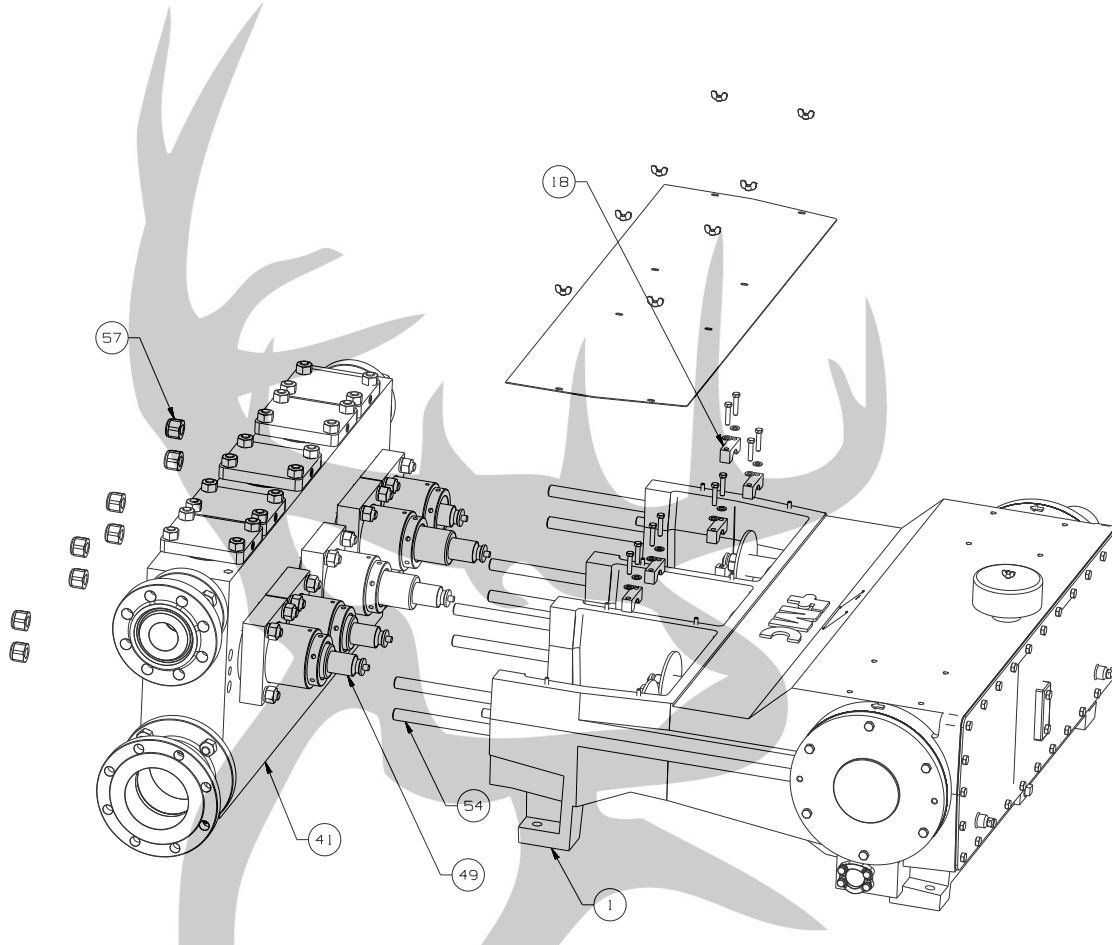

**BUCKHORN  
PUMPS, INC.**  
Figure 5: Fluid Cylinder Removal

### 10.3 Replacing Valves

Two types of valves may be supplied with various models of the Q16 and Q18 series pumps. They are disc valves or AR (Abrasion Resistant) style valves. The AR valves are commonly used when pumping abrasive fluids. The next steps in this section must be performed for either type of valve.

A minimum of approximately 3 feet (0.9 M) of clearance is required above fluid cylinder to allow valve service without removal of the fluid end. If sufficient clearance is not available, the fluid end must be removed as outlined in previous section and taken to a work shop for valve service. The following procedure is written under the assumption that sufficient clearances exist.



**WARNING:** Many accidents occur every year through careless use or service of mechanical equipment. You can avoid hazards associated with high-pressure equipment by always following the safety precautions listed in Section 1.0.

**CAUTION: CHECK TO INSURE THAT THE POWER IS LOCKED OUT AND TAGGED OUT.**

1. Loosen the hex nuts (58) that retain the five valve covers (50) on the top of the fluid cylinder. Remove the valve covers.
2. For AR type valves refer to section 10.3.1. This section describes the methods for removing and installing the AR valves.
3. For disc type valves refer to section 10.3.2. This section describes the methods for removing and installing disc valves.
4. After the valves have been replaced, inspect each o-ring (51) on each valve cover (50). FMC suggests that the valve cover o-rings be replaced if nicked or if the o-ring has any other damage.
5. Install the valve cover with the o-ring in place over the studs (55). Installation Tip: Apply grease around each o-ring on the valve cover to prevent the o-ring from falling out of the cover when turned over for cover installation. Replace valve cover washers (60) and the valve cover hex nuts (58).
6. Torque the cover hex nuts to the recommend values listed in the Fastener Torque Requirements, Section 11.0, of this manual.

### 10.3.1 Replacing AR Valves

#### 10.3.1.1 Introduction

The AR (Abrasion Resistant) valve is a durable wing-guided, spring-loaded check valve. It is used with abrasive fluids, bentonite mud, water, oil etc., and provides excellent performance and long service life. A typical valve is shown in Figure 6 with valve components identified in the exploded view to the right.

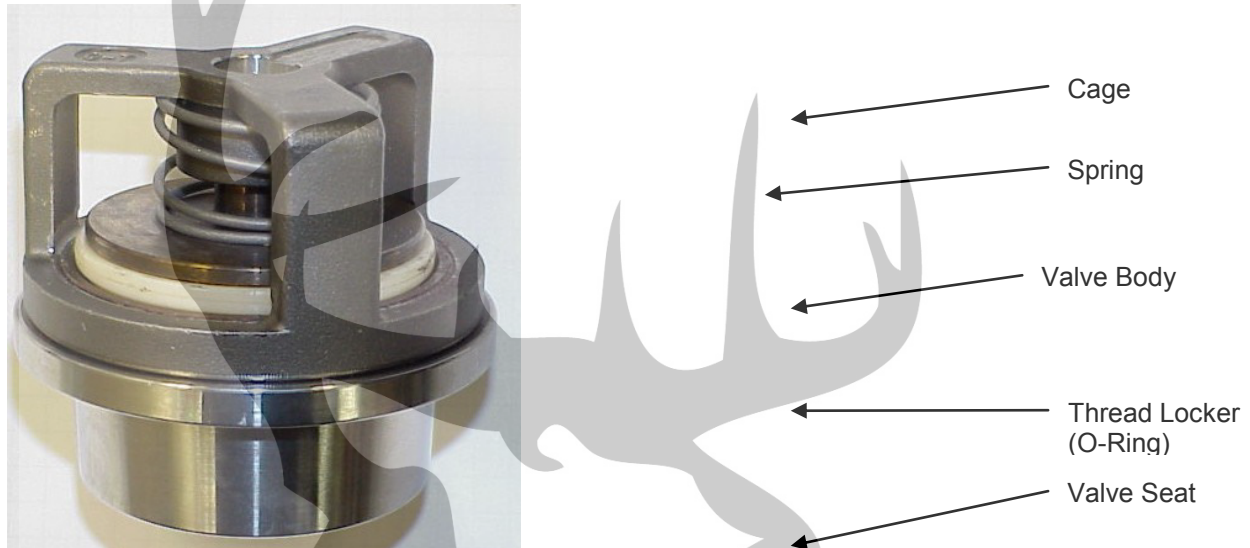

Figure 6: AR Valve Assembly

The primary difficulty in removing an AR Valve is associated with the removal of the tapered seat from the matching locking taper in the fluid cylinder. If the pump is used for discharge pressures in excess of 3,000 psi or for corrosive fluids, this can be a difficult task requiring specialized tooling. For applications involving pressures of 5000 psi or more, FMC recommends the use of AR valves with threaded through bores. Refer to Section 10.3.1.4 for the threaded type puller.

FMC provides three types of tools that can be used to remove the AR type valves. Some of the tools are specific to the pump model; some are used only with specific valves and others can be used with any AR installation. They each have advantages and disadvantages. Refer to section 13, Valve Removal and Installation Tools, Table 7 for the appropriate tool recommendations.

### 10.3.1.2 Eccentric Discs

This style can be used on all sizes of the AR valves in either of the pump models. The discharge valve is removed first. The valve must be disassembled with the cage, spring and valve body removed from the fluid cylinder prior to the seat being pulled. A special hex drive tool will assist in removing the cage from the seat.

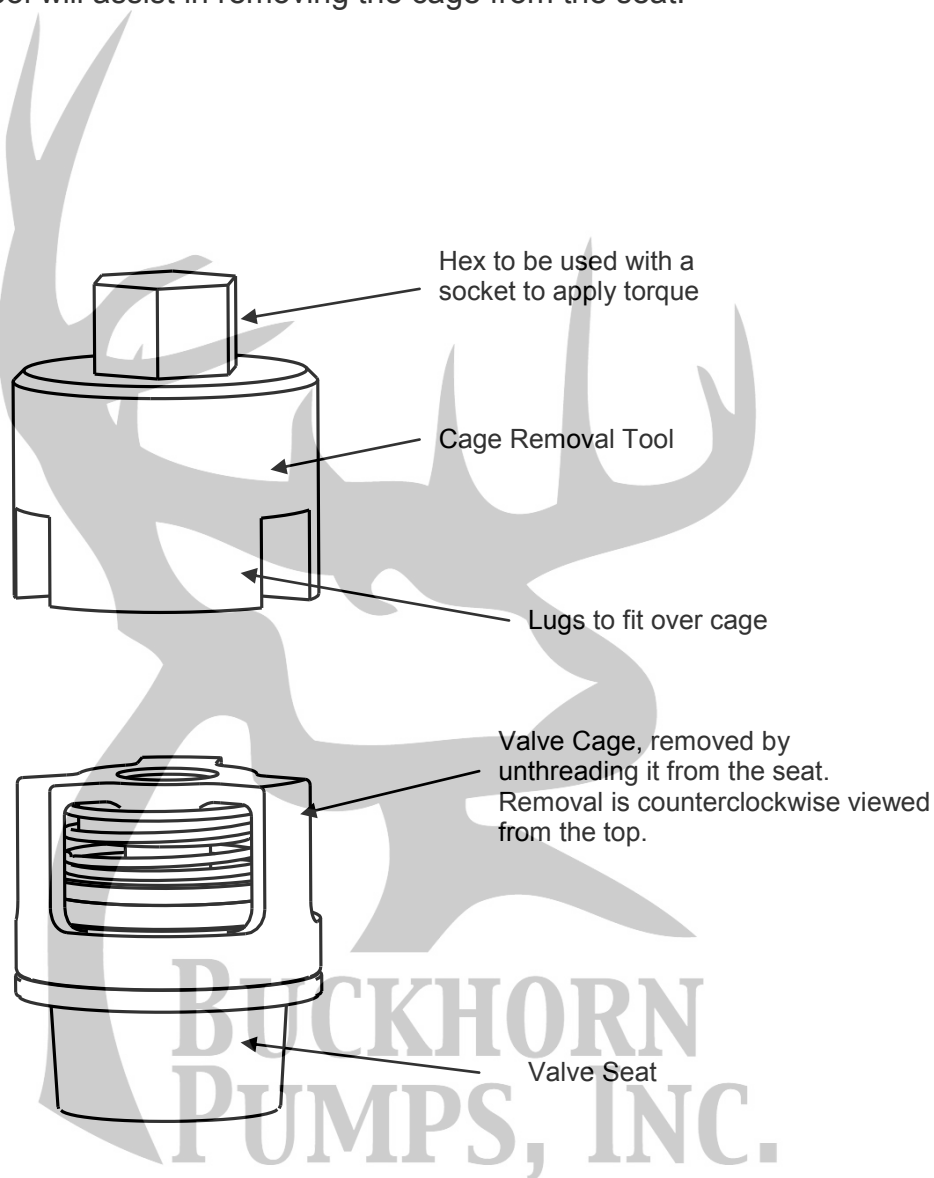

Figure 7: Valve Disassembly

This style of tool includes a disc that passes through the seat to allow tension to be placed underneath it. The disc has a threaded hole that is at the center of the disc (concentric disc). A tension rod is threaded into the hole. The second disc has an eccentric hole with clearance for the tension rod and sits on top of the threaded disc. This keeps the threaded disc engaged with the edge of the seat.

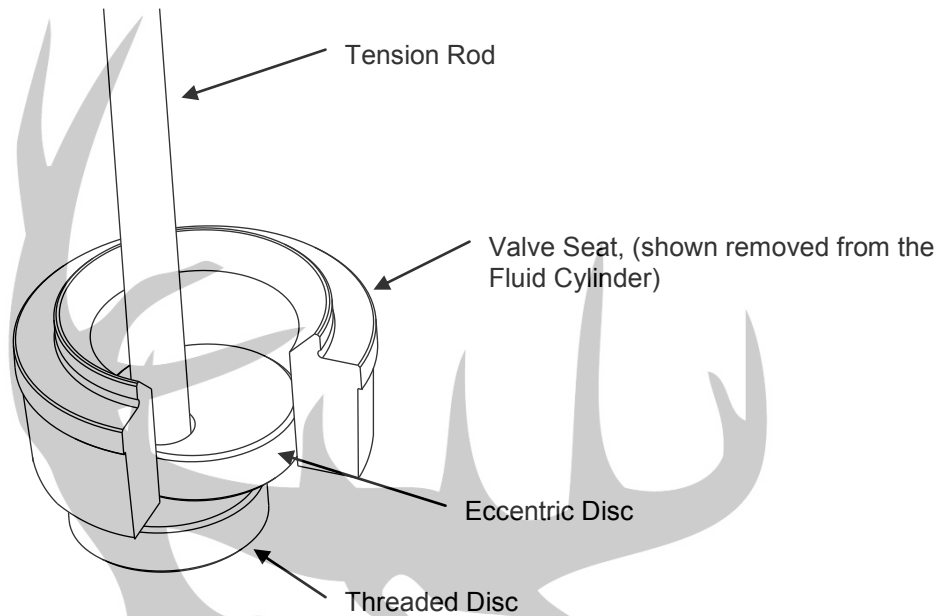

Figure 8: Eccentric Disc in Use

The tension rod is located through the top of the fluid cylinder and through a strong back that rests on the top of the fluid cylinder. A nut is threaded over the tension rod and tightens down on the strong back. The nut is tightened to place tension in the rod, putting upward pressure on the seat of the fluid cylinder.

A bumper is placed over the tension rod with a nut stop above the bumper. With the nut on the strong back torqued (tensioning the rod) rapidly move the bumper upward striking the retaining nut. This imparts a shock load into the seat. This sequence is repeated until the seat pops loose from the fluid cylinder.

**WARNING:** The seat may pop suddenly when force is applied. Stand with feet apart when applying striking action. Keep head back so tool does not strike your jaw when the seat pops. Ask for a work partner to steady you to avoid slipping. The bumper sliding upward against the stop nut creates a pinch point that can cause hand injury if gripped improperly. Always hold the bumper by the handles only and use leather work gloves to lessen the shock to your hands.



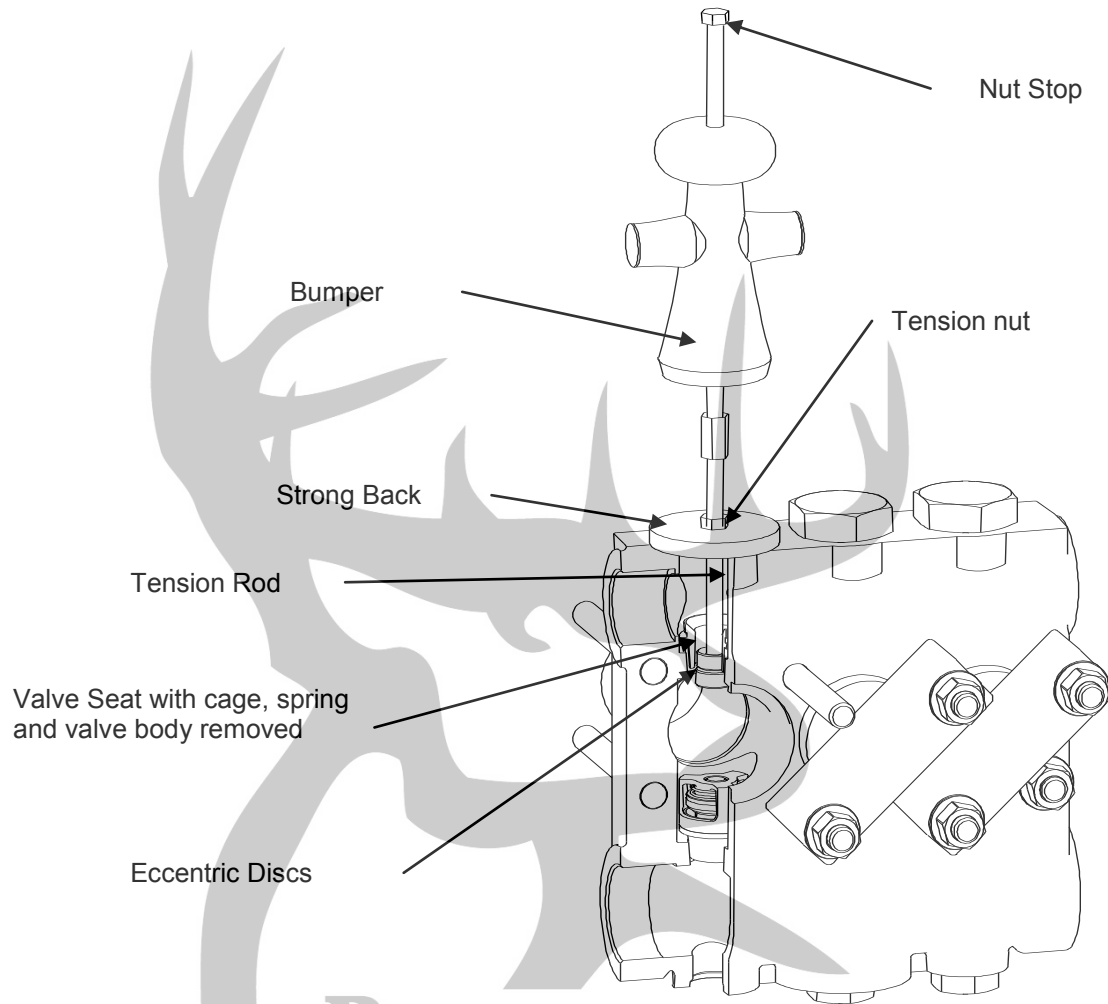

BUCKHORN  
PUMPS, INC.

Figure 9: Removing the seat

A variation of this is the use of a hydraulic pump and cylinder jack (porta power) to generate the load that the bumper, strong back, and nut would generate. This is shown in Figure 10. It is useful to put "dry ice" on the seat if it will not loosen. Allow five minutes for cooling of seat before attempting removal.

**CAUTION:** Dry ice will cause freeze burns to skin if contacted. Use thick leather gloves when handling. Dry ice is often available at grocery stores.

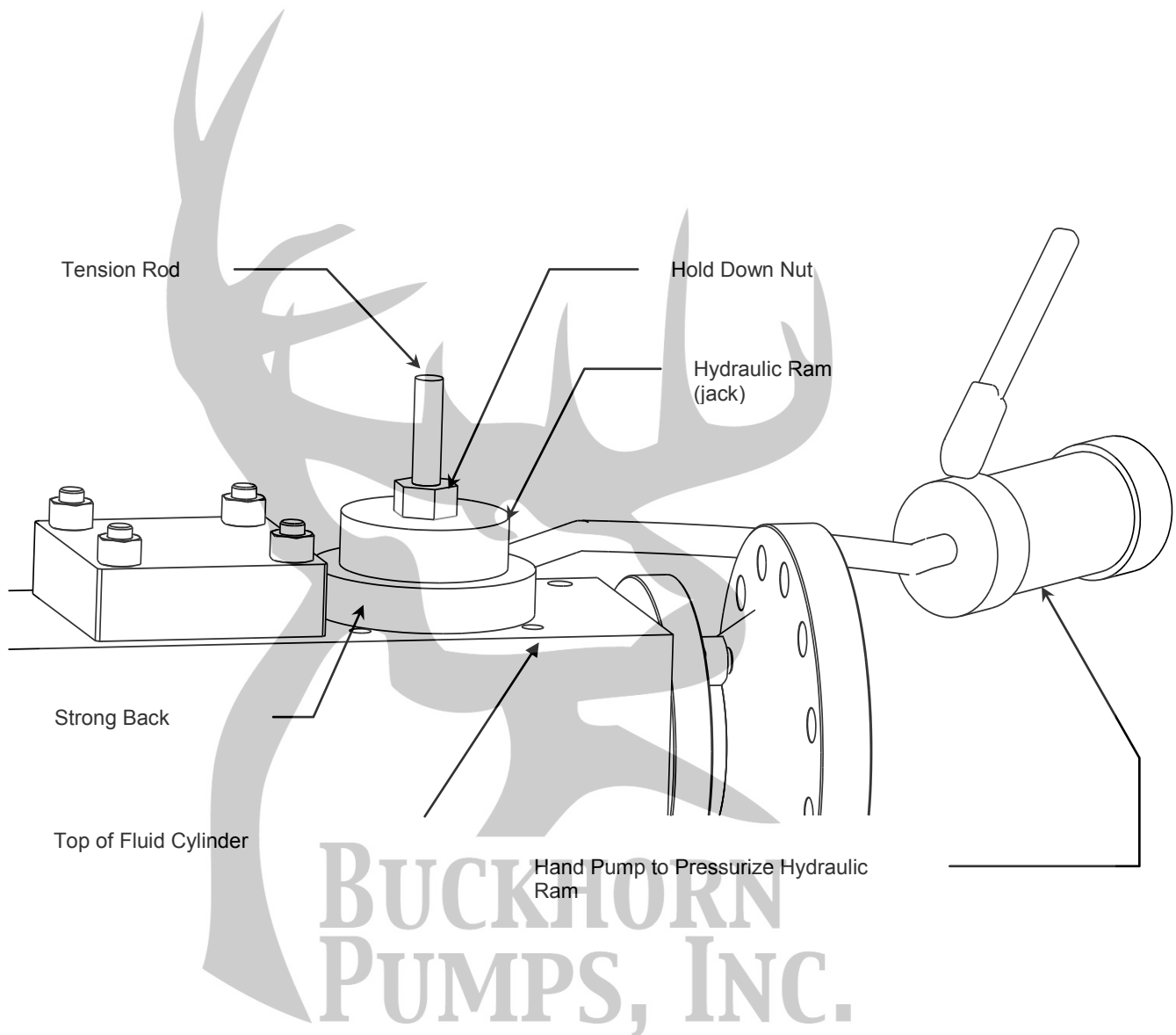

Figure 10: Hydraulic Power used to Remove Valve Seat

### 10.3.1.3 Mandrel Type

This is a variation of the Eccentric Disc type. It can be used on all sizes of valves. It has a more uniform loading of the seat than the Eccentric Disc type and therefore more pulling capacity. A unique size is required for each valve size and the cost is usually higher than the Eccentric Disc. Refer to Picture 1 to see a typical mandrel type tool.



Picture 1: Mandrel Type Tool

**BUCKHORN  
PUMPS, INC.**

**NOTE:** Similar to the Eccentric Disc type of puller, the valve must be disassembled and the cage, spring and valve body removed leaving only the seat in the fluid cylinder.

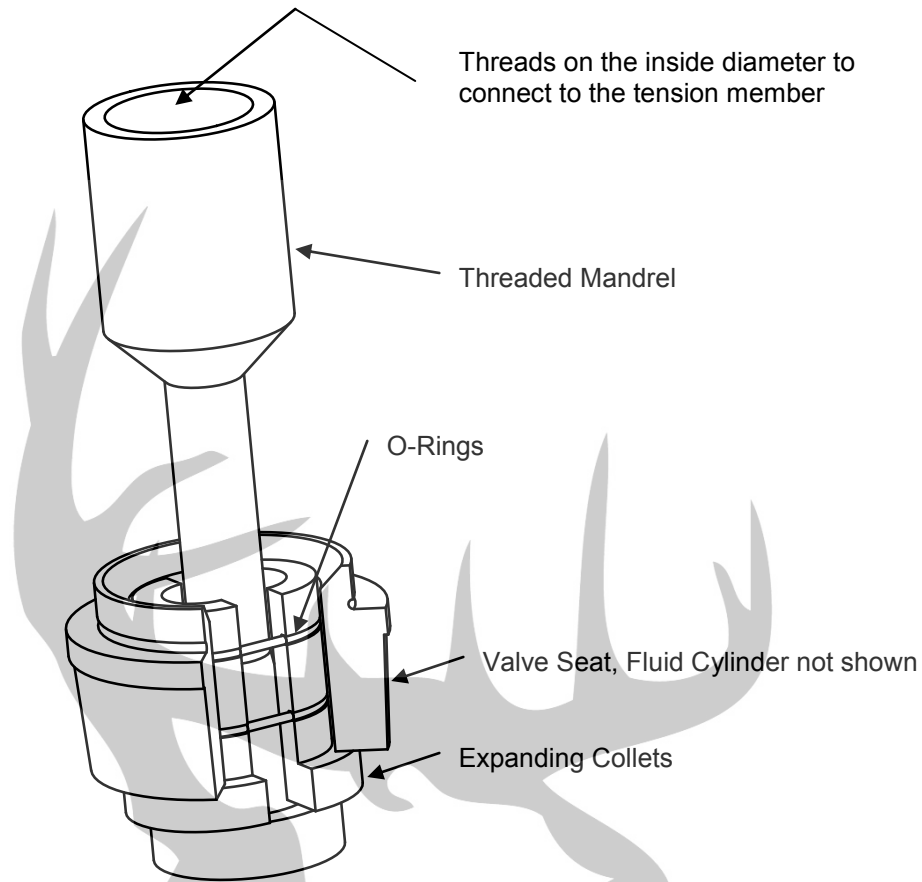

Figure 11: Mandrel Tool in use

**BUCKHORN  
PUMPS, INC.**

The lower part of the mandrel and the collets are passed through the valve seat and then slid down the mandrel to expand them. The o-rings keep the collets on the mandrel. The tension is applied in the same way as was done for the Eccentric Disc type.

**10.3.1.4 Threaded Type (AR Valves Only)**

The threaded type can only be used on valves that have the through bore of the seat threaded prior to installation. The load capacity is similar to the Mandrel Type but it is simpler to use. This is the last variation of methods of applying tension to the valve seat to remove it from the fluid cylinder.

Again the valve must be disassembled with the cage, spring and valve body removed leaving only the seat in the fluid cylinder prior to use of the puller.

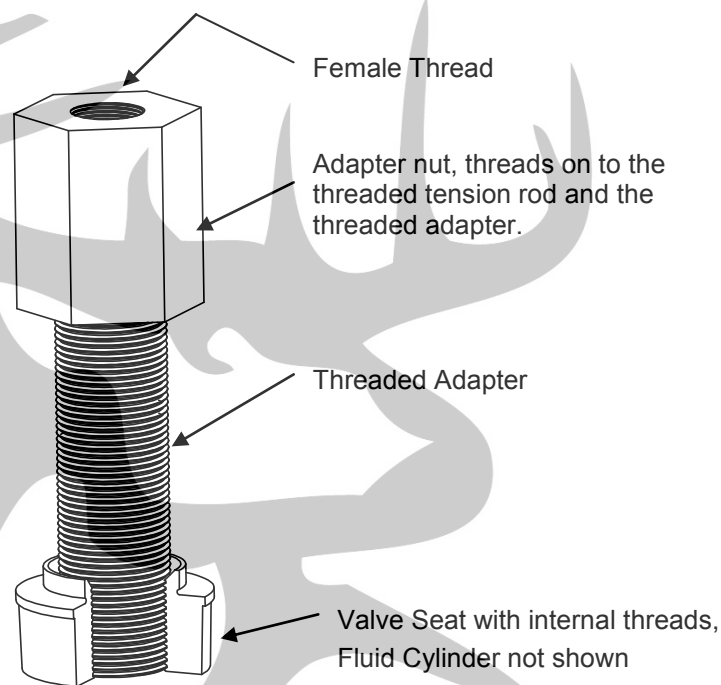

Figure 12: Threaded Tool in use

A threaded adapter is screwed into the seat after the cage, spring, and valve body have been removed. An adapter nut mates the threaded section to the tension rod, strong back and other parts used on the Eccentric Type to apply tension and then impact loading to remove the seat from the fluid cylinder.

The threaded seat is new to the FMC product line and as such it is being used on applications where the removal force for the seat is expected to be high. With high

removal forces required, the hydraulic puller is recommended over the nut, bumper, strong back, and puller assembly.

### 10.3.1.5 Installation of AR Valves

AR valves are installed differently depending on their size. Larger valves (most Series 5 or 25 and larger) are assembled at the factory with the cage screwed on hand-tight before shipping while smaller valves (Series 5 or 25 with 2.09 Gage Line and all Series 7 or 27 and larger) are tightened with a torque wrench to final specifications. Follow the instructions in section 10.3.1.5.1 for series 3 (P/N 3263921 and 3263922). See section 10.3.1.5.2 for all larger AR valves.

#### 10.3.1.5.1 Installing Smaller, Factory Torqued AR Valves

The suction valve must be installed before the discharge valves. The following reassembly procedure is applicable for both.

1. Select a new valve assembly.
2. Carefully clean the taper in the fluid cylinder and on the valve seat with a cleaning solution and a clean cloth. Small scratches can be removed with steel wool or 100 grit emery paper. Remove all dirt, grease, oil, water, or other contaminants from the surfaces. Do not oil the seats or the seating surfaces in the fluid cylinder. Confirm that they are dry before installation.
3. Position the valve assembly directly over the mating taper in the fluid cylinder.
4. Let the valve drop into the taper. Check to see that the seat is sitting in the taper properly and not cocked to one side. If the valve drops straight, it will seize on the taper. When correctly seated, it cannot be pulled up by hand.
5. Place the small end of the knockout tool, part number P504436 (see Section 10.3.1.2), through the hole in the cage onto the center of the valve body.
6. While applying downward pressure on the tool, strike the end two times with a hammer to seat the valve. Be very careful not to strike the cage as this will cause the valve to be damaged and fail.
7. Verify that the valve body moves freely.
8. The cage torque is 30 ft-lbs (40.7 N-m).

### 10.3.1.5.2 Installing Larger, Non-Factory Torqued AR Valves

The larger valves are Series 5 or 25 with 2.09 Gage Line and larger (Series 7 or 27 and up). The suction valve must be installed before the discharge valves. The following reassembly procedure is applicable for both.

1. Select a new valve seat. Disassembly of a new valve assembly may be necessary. **Do not install complete assembled valves.**
2. Carefully clean the taper in the fluid cylinder and on the valve seat with a cleaning solution and a clean cloth. Small scratches can be removed with steel wool or 100 grit emery paper. Remove all dirt, grease, oil, water, or any other contaminants from the surfaces. Do not oil the seats or the seating surfaces in the fluid cylinder. Confirm that they are dry before installation.
3. Position the valve seat directly over the mating taper in the fluid cylinder.
4. Let the seat drop into the taper. Check to see that the seat is sitting in the taper properly and not cocked to one side. If the valve drops straight, it will seize on the taper. When correctly seated, it cannot be pulled up by hand.
5. Place a flat clean piece of brass or plastic on the face of the seat. If available, an old valve disc will work well. With a metal rod or punch, strike the end of the tool two times with a hammer to seat the valve.
6. After the seat is secured in the fluid cylinder, the valve must be assembled. Apply anti-seize solution to the cage threads before threading onto the seat. Care must be taken when threading the cage onto the seat. This is a very fine thread and can easily be damaged by cross-threading. Tighten the cage against the o-ring which acts as a thread locking device. Torque the cage to 30 ft-lbs (40.7 N-m).

NOTE: Use the hex cage removal tool for reassembly. The tool is shown in Figure 7.

BUCKHORN  
PUMPS, INC.

## 10.3.2 Replacing Disc Type Valves

### 10.3.2.1 Introduction

The disc type valve is used in many of the FMC pump models. The standard construction of stainless steel seat, cage, and bolt with a Delrin® disc are time proven to be a cost effective design with excellent performance and ample life. Other materials of construction including titanium disc and Hasteloy seat are available. A typical valve is shown in Picture 2.

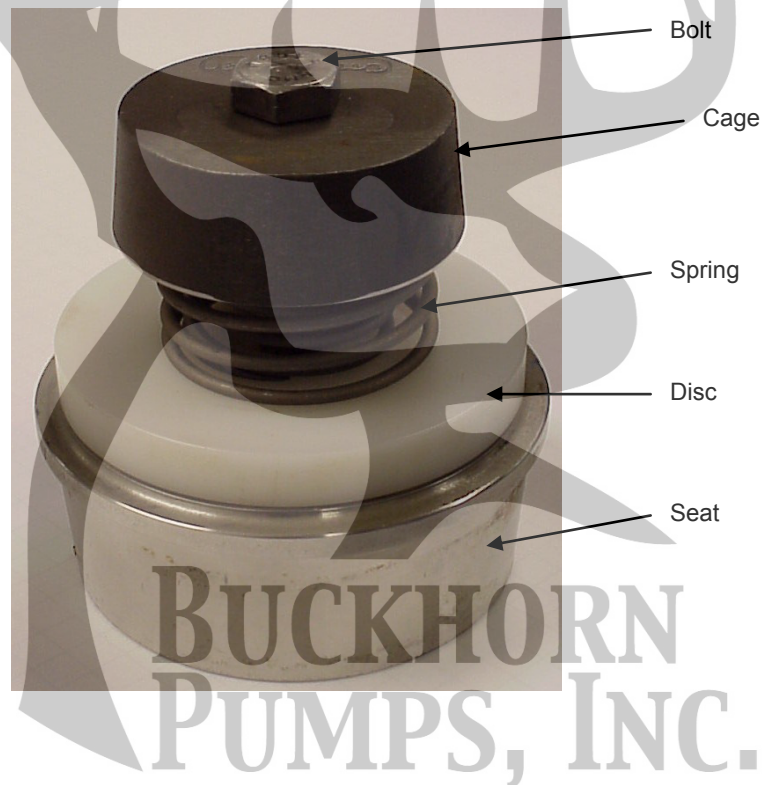

Picture 2: Typical Disc Valve Assembly



A significant characteristic of the disc valve is the number of webs in the seat. This feature is a factor in determining the maximum allowable discharge pressure of the valve and the methods available to remove them. The valve seat either has three (3) or five (5) webs; see Picture 3 and Picture 4.

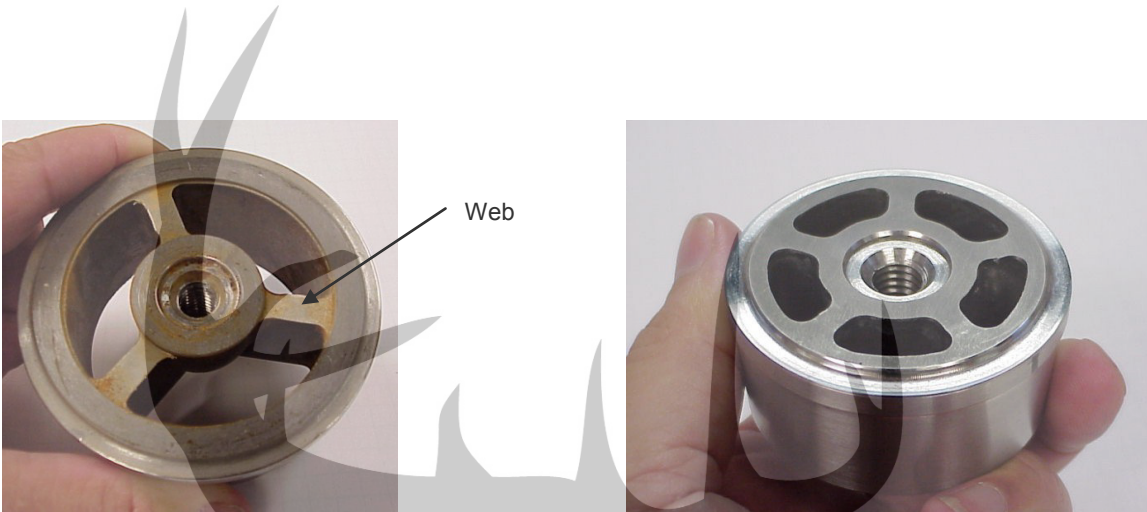

Pictures 3 and 4: Three vs. Five Web Valve Seat

When a worn or malfunctioning valve is detected it must be replaced. With disc valves the most difficult task associated with replacing a valve is the removal of the seat from the fluid cylinder. The seats are held into the fluid cylinder with a matching locking taper. Removal is particularly difficult if the discharge pressure of the pump was over 3,000 psi or corrosive fluid was pumped.

### 10.3.2.2 Valve Puller with Threaded Tools

The threaded rod must be used for all of the five web valves and can be used on the smaller sizes of the three web valves. The discharge valve is removed first. The valve must be disassembled with the bolt, cage, spring and disc removed from the fluid cylinder prior to the seat being pulled. To disassemble the valve simply remove the bolt and lift off the cage, spring and disc.

This puller has a threaded rod, which is screwed into the threaded hole at the center of the seat. The threaded rod is connected to a tension rod that is located through the top of the fluid cylinder and through a strong back that rests on top of the fluid cylinder. A nut is threaded over the tension rod and tightens down on the strong back. The nut is tightened to place tension in the rod, putting upward pressure on the seat in the fluid cylinder.

A bumper is placed over the tension rod and a nut above the bumper. With the nut on the strong back torqued the bumper is moved rapidly upward striking the retaining nut. This imparts a shock load into the seat. This sequence is repeated until the seat pops loose from the fluid cylinder.

**WARNING:** The seat may pop suddenly when force is applied. Stand with feet apart when applying striking action. Keep head back so tool does not strike jaw when seat pops. Ask for a work partner to steady you to avoid slipping.

**CAUTION:** The bumper sliding upward against the stop nut creates a pinch point that can cause hand injury if gripped improperly. Always hold the bumper by the handles only.



BUCKHORN  
PUMPS, INC.

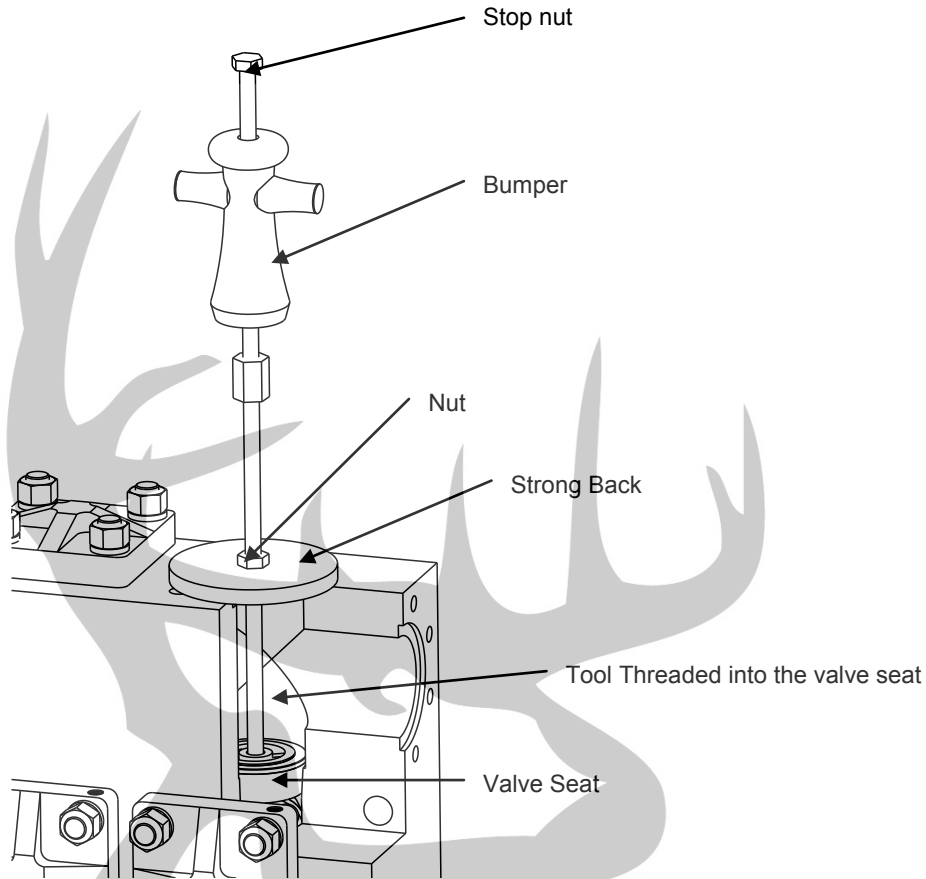

Figure 13: Removing Seat with threaded tool

BUCKHORN  
PUMPS, INC.

A variation of this is the use of a hydraulic pump and cylinder jack (porta power) to generate the load that the bumper, strong back and nut would generate. This is shown in Figure 14. It is useful to put "dry ice" on the seat if it will not loosen. Allow five minutes for cooling of seat before attempting removal.

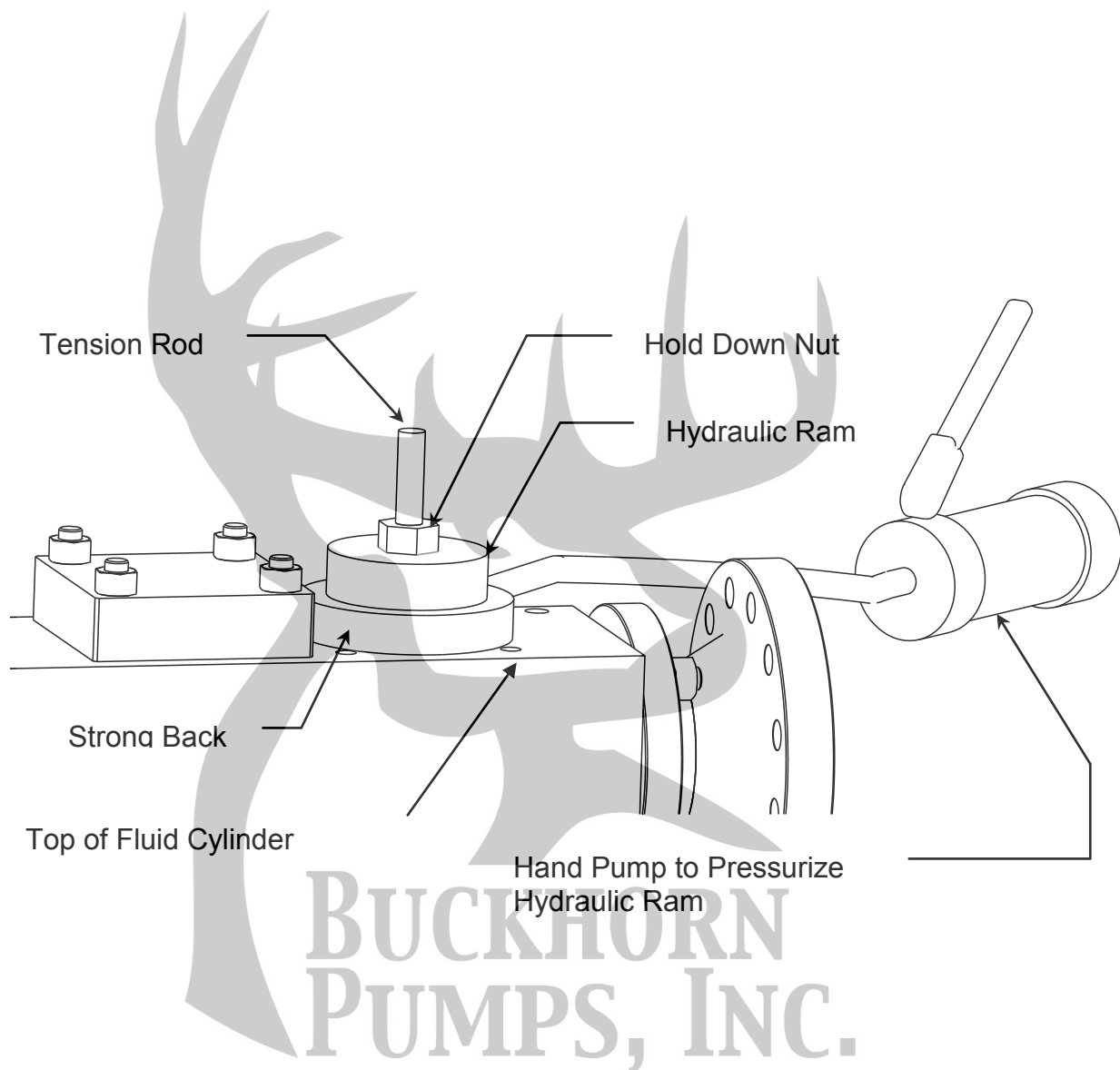

Figure 14: Hydraulic Power Used to Remove the Seat

**10.3.2.3 J Hook Tool**

The J Hook Tool is a reliable tool that will only work with the three web valves. The tool is dropped into the valve seat and then rotated to hook over the three webs. The valve must be disassembled first.

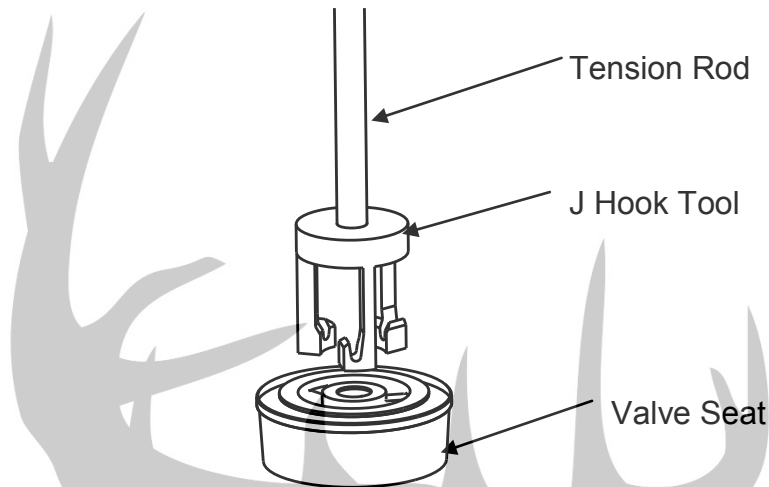

Figure 15: J Hook being inserted into the valve seat

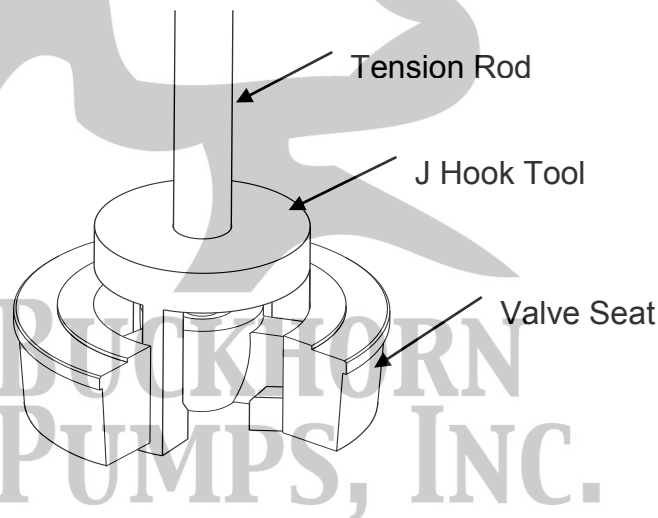

Figure 16: J Hook latched into the Valve Seat

With the tool hooked on the seat, tension is as with the threaded tool. The hydraulic power pack and annular piston may also be used.

**10.3.2.4 Installation of Disc Valves**

The suction valves must be installed before the discharge valves can be installed. The following reassembly procedure is applicable for both.

1. Select a new valve seat. Disassembly of a new valve assembly may be necessary. Do not install complete valves while assembled.
2. Carefully clean the taper in the fluid cylinder and on the valve seat with a cleaning solution and a clean cloth. Small scratches can be removed with steel wool or 100 grit emery paper. Remove all dirt, grease, oil, water or any other contaminants from the surfaces. Do not oil the seats or the seating surfaces in the fluid cylinder. Confirm that they are dry before installation.
3. Position the seat directly over the mating taper in the fluid cylinder.
4. Let the seat drop into the taper. Check to see that the seat is sitting in the taper properly and not cocked to one side. If the seat drops straight, it will seize on the taper. When correctly seated, it cannot be pulled up by hand.
5. Place a flat and clean piece of brass or plastic on the face of the seat. An old valve disc will work well. With a metal rod or punch strike the brass or plastic three times with a hammer to seat the valve.
6. After the seat is secured in the fluid cylinder, the valve must be reassembled. Care must be taken to position the valve plate and the retainer so as not to damage the guide while tightening the fastener. The fastener must be torqued. Below is a chart showing the recommended torque values and the typical socket or Allen wrench size.

Fastener Size, In	Torque		Hex Size	Hex Size
	ft-lbs	N-m	Cap Screw, In	Allen Screw, In
3/8	30	41	9/16	5/16
1/2	40	54	3/4	3/8
5/8	60	81	15/16	1/2

Chart 1: Torque Values for the Fastener

## 10.4 Servicing the Power End

### 10.4.1 Replacing Plunger Rod Oil Seals and Plunger Rods



**WARNING:**

Many accidents occur every year through careless use or service of mechanical equipment. You can avoid hazards associated with high-pressure equipment by always following the safety precautions listed in Section 1.0.

NOTE: Insure that all pressure inside the pump fluid cylinder has been bled off before starting any service work. **CAUTION: CHECK TO INSURE THAT THE POWER IS LOCKED OUT AND TAGGED OUT.**

1. Remove the cradle cover (40) from the power frame (1) by removing the wing nuts (38). Some power ends include a machined cradle area (sealed cradle) and have approximately 22 nuts to remove.
2. The plunger rod oil seals (26) retain oil in the power frame and prevent dirt, water, or other contaminants from entering the power frame by way of the plunger rods. The fluid end need not be disturbed to perform this procedure.
3. Unbolt the plunger clamps (18) and remove them from the plungers (49) and plunger rods (7).
4. Rotate the crankshaft (2) by hand until one of the plungers (49) is moved fully forward, toward the fluid cylinder (41), and the plunger rod (7) is fully retracted. Refer to Section 10.1, paragraph 4 for detailed instructions on sliding the plunger forward.
5. Slide the deflector shield (24) off the end of the plunger rod (7).
6. Unbolt the cap screws (20) holding the plunger rod seal housing (19) to the power frame. A slot in the outside diameter of the plunger rod seal housing has been provided for a screwdriver to assist with removal. Pull the seal housing over the end of the plunger rod and out of the cradle. Repeat steps 3, 4, and 5 for the other four seal housings. Service Tip: Spray the seal housing outside diameter (where it joins the power frame) and plunger rod with penetrating oil like WD-40 to aid removal.
7. Remove the seals (26) and the o-ring (25) from the seal housing (19). Note the orientation of each seal prior to removing it.
8. Inspect the plunger rod at this time. If it is scored or damaged in any way it must be removed. To remove the plunger rod unscrew it from the crosshead (6). A

new plunger rod is screwed into the crosshead and torqued per the Fastener Torque Requirements, Section 11, of this manual.

9. Install a new o-ring (25) and new seals (26) in the seal housing (19) in the same orientation that they were originally.
10. Replace the seal housing (19) in the power frame cradle over the plunger rod and into position in the counterbore. Tap into position using a rubber mallet. The cap screws (20) can be used to evenly draw the seal housing into place. Take care to avoid folding the lips back when they are pushed over the plunger rod or cutting the o-ring when the seal housing is installed in the power frame. Apply a few drops of motor oil on the plunger rod and the seal bore in the power frame to aid this process and provide lubrication to the seals during start-up.

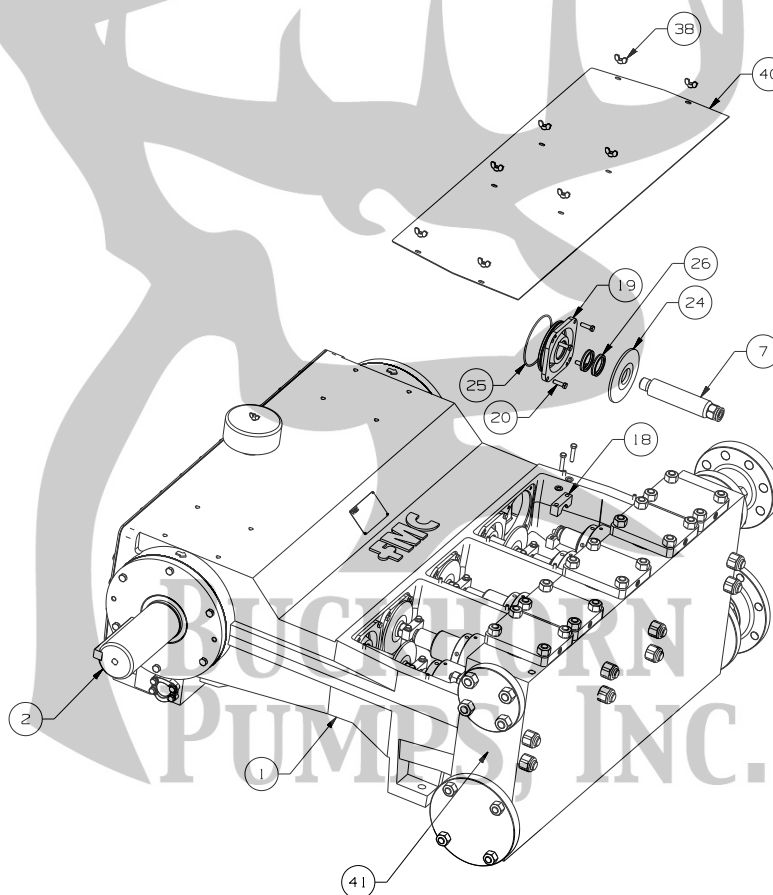

Figure 17: Oil Seal and Plunger Rod Replacement



### 10.4.2 Servicing the Connecting Rod Bearings

NOTE: Insure that all pressure inside the pump fluid cylinder has been bled off before starting any service work. **CAUTION: CHECK TO INSURE THAT THE POWER IS LOCKED OUT AND TAGGED OUT.**

1. The cradle cover (40) and plunger clamps (18) should be removed to perform the steps in this section. Refer to the procedures in Section 10.4.1.
2. Remove magnetic pipe plug (29) to allow all oil to drain from power frame into a container for proper disposal. Use proper precautions if power frame is hot (above 130° F, 54° C) to avoid burns from hot oil or hot surfaces.
3. Remove all rear cover cap screws (22). Remove the back cover (11) and back cover gasket (17) from the power frame.

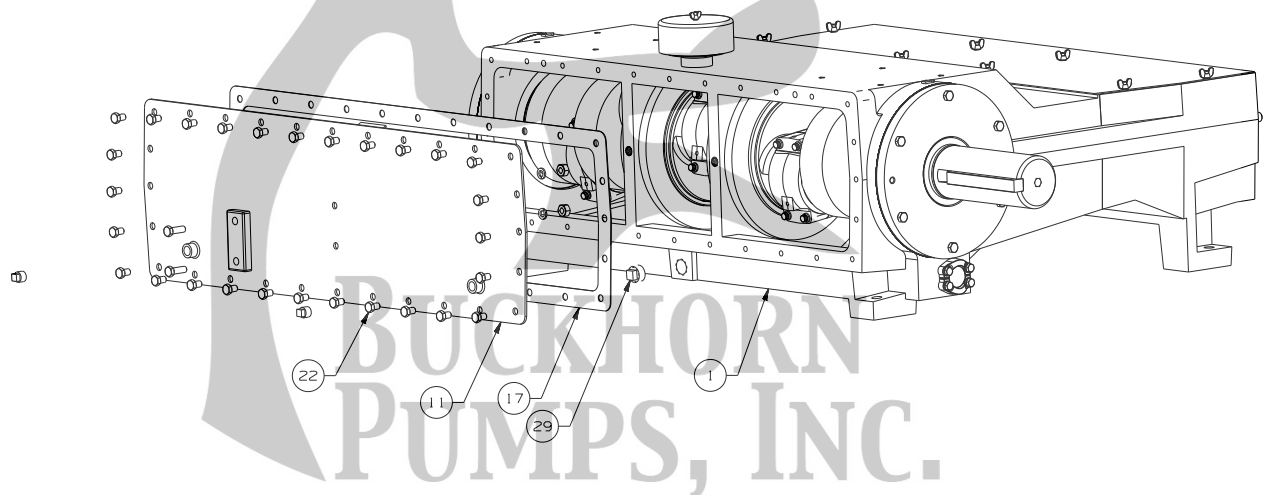

Figure 18: Back Cover Removal

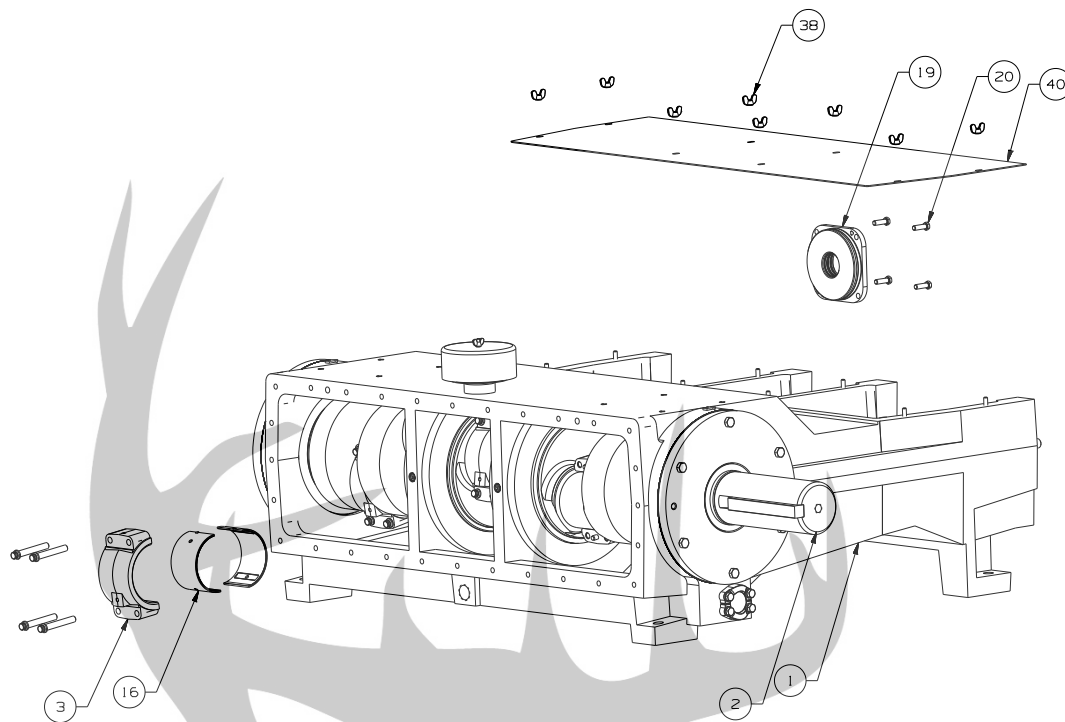

Figure 19: Rod Bearing and Oil Seal Removal

4. Rotate the crankshaft (2) to position the connecting rod end cap (3) nearest the opening and remove the end cap of the connecting rod by unscrewing the cap screws (two on the Q16 pump and four on the Q18 pump) that hold each cap to the connecting rod body. Rotate the crankshaft to reposition the remaining end caps and repeat the end cap removal. The cap can be removed from the body by tapping with a rubber mallet on the heads of the cap screws when they are partially removed. It may also be required to tap on the head of the connecting rod to loosen it. Take care to not damage the threads on the cap screws.
5. Slide the two rod bearing halves (16) from each connecting rod (3). Note that these parts sometimes adhere to the pins (journals) on the crankshaft.
6. NOTE: Connecting rods and caps are matched sets and must always be reassembled with their original mate and in the same orientation. Note the numbered codes stamped on each half of the connecting rod assemblies and make certain they are installed as matched set and in the same orientation when re-assembling the pump.

7. Inspect the crankshaft journals and other internal parts for damage.
8. Clean all parts before assembly and clean the sump area of the power frame.
9. Reinstall or replace rod bearings (16) in the connecting rod and connecting rod caps. Insure that the rod caps are properly assembled with their mating connecting rod. Torque the fasteners holding the end caps to the mating rod per the values given in Fastener Torque Requirements, Section 11.0 of this manual. Use back and forth pattern from one fastener to the other on Q16 pump and criss-cross tightening pattern on Q18 pump when tightening with a torque wrench. Begin at approximately 25% of the final torque value, then to 50%, and finish at full torque. After the cap screws are torqued, a light strike to the cap with a rubber mallet will help properly seat the rod bearings.
10. Inspect the back cover gasket (17) and replace if damaged. Install back cover gasket and back cover. Torque the back cover fasteners (22) per the values given in Fastener Torque Requirements, Section 11.0 of this manual.
11. Reinstall the plunger clamp assemblies (18) per section 10.4.1 instructions.
12. After reassembly be sure to fill the pump power end with the proper amount of lubricating oil. Refer to the start-up check list in Section 18.2, "Checklist for Starting a Pump", before restarting your pump.



BUCKHORN  
PUMPS, INC.

### 10.4.3 Servicing Bearing Housings, Crankshaft, and Crossheads



**WARNING:** Disconnect the driver from the pump and insure that suction and discharge lines are disconnected or blocked and have no pressure applied.

NOTE: Insure that all pressure inside the pump fluid cylinder has been bled off before starting any service work. **CAUTION: CHECK TO INSURE THAT THE POWER IS LOCKED OUT AND TAGGED OUT.**

Installation Tip: Mark each bearing housing and the power frame to allow installation back in the original position and orientation.

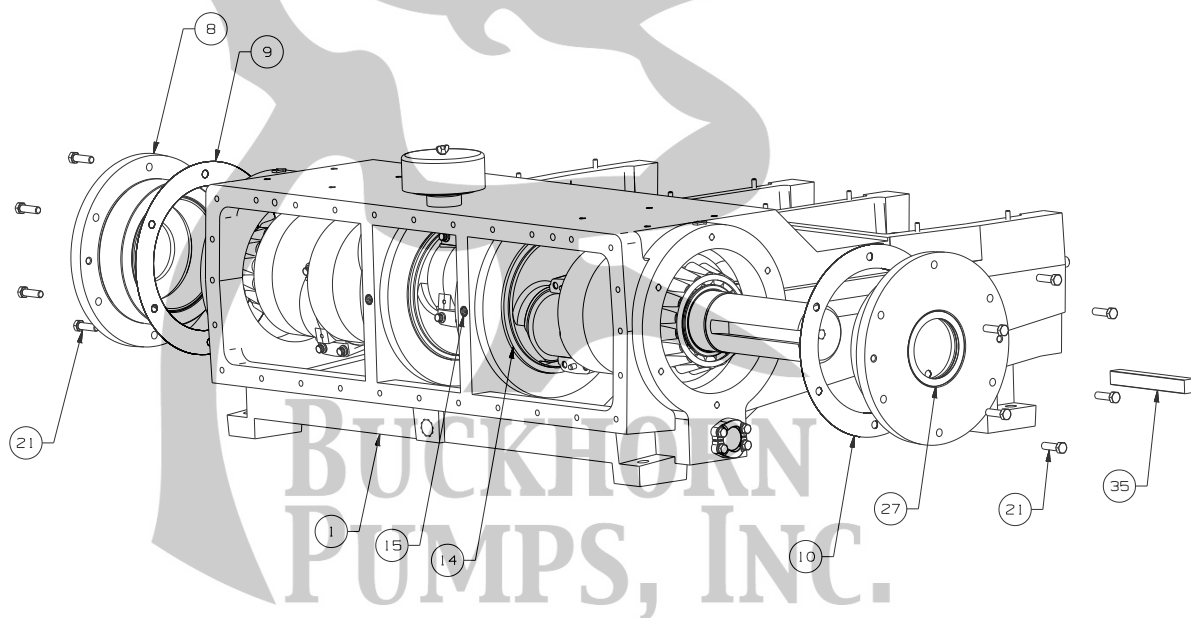

Figure 20: Crank Bearing Removal

1. The cradle cover (40), plunger clamps (18), and back cover (11) should be removed to perform the steps in this section. Refer to the procedures in Section 10.4.1 and 10.4.2 for details.
2. The plunger rod seal housings (19) must be removed to allow the connecting rod (3) and crosshead assemblies (6 & 7) to move forward enough for crankshaft removal. Refer to Section 10.4.1, "Replacing Plunger Rod Oil Seals and Plunger Rods" for instructions.
3. Remove the connecting rod bolts, connecting rod caps, and shell bearings as described in Section 10.4.2. Push the connecting rod and crosshead assemblies as far forward into the power frame as possible to provide clearance for the crankshaft.
4. Using feeler gauges, check the radial clearance between the crankshaft and center support bearings (14). If clearance exceeds 0.010 inches, the bearings will require replacement.
5. Remove the hex head cap screws (21), bearing housings (8), shims (10), and if the gaskets (9) are not adhering, remove them from both sides of the pump.  
Service Tip: It may be necessary to tap on the bearing housing with a rubber mallet to free it from the power frame after the hex head cap screws have been removed. If that is not adequate, tapped jack screw holes, which are the same size as the cap screw holding the housing in place, have been provided in each bearing housing to help remove stuck housings. The center bearings will support the crankshaft.
6. Count and record the number of shims on each side to facilitate reassembly. The gaskets may adhere to the power frame surface and can be left in place if they are not damaged. The bearing cups (12) and crankshaft oil seal (27) will remain in the bearing housing.
7. To remove the crankshaft, carefully move it through one side of the bearing housing opening in the power frame. It is recommended that two people be available for crankshaft removal due to the size and weight. A hoist and counterbalance lifting device should be used during crankshaft removal. The crankshaft should be handled carefully to prevent the critical bearing surfaces from being scratched or damaged.

BUCKHORN  
PUMPS, INC.

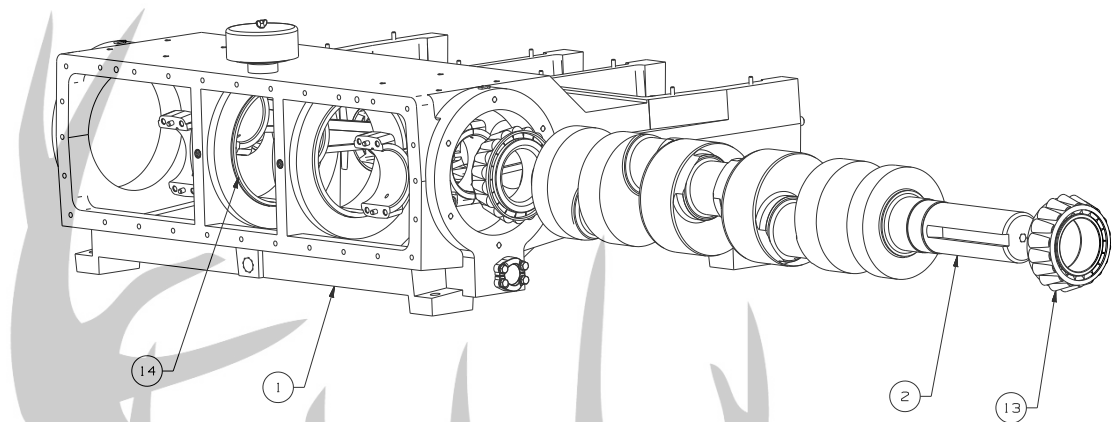
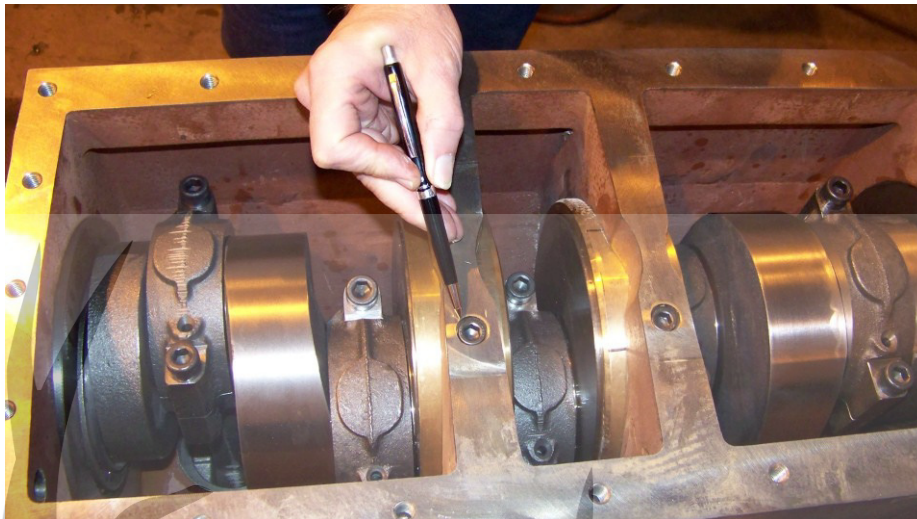

Figure 21: Crank Removal

8. Inspect the center support crankshaft bearings (14) for scoring or galling of the Babbitt surface or for imbedded debris. Minor concentric scratches caused by small debris passing through the bearing are not cause for replacement.
9. If bearings are damaged or clearance measured in step 4 exceeds 0.010 inches, the center support bearings will need to be replaced. Remove the socket head lock screws (15) that retain the bearings and then pull the bearings. Refer to Picture 5 for locking screw location.
10. The use of an all-thread rod and a plate machined to fit the bearing will allow for proper removal and allow the new bearings to be installed. Refer to Figure 22 for an illustration of the puller arrangement. **NOTE:** Align the lock screw relief in the bearing OD with the threaded hole in the power frame to allow for installation of the lock screw. It is important that the lock screw engage the relief hole in the OD of the bearing to prevent rotation. If the screw does not engage the hole in the bearing, the screw will push against the outside of the bearing and cause deformation.



Picture 5: Locking Screw for Center Bearing

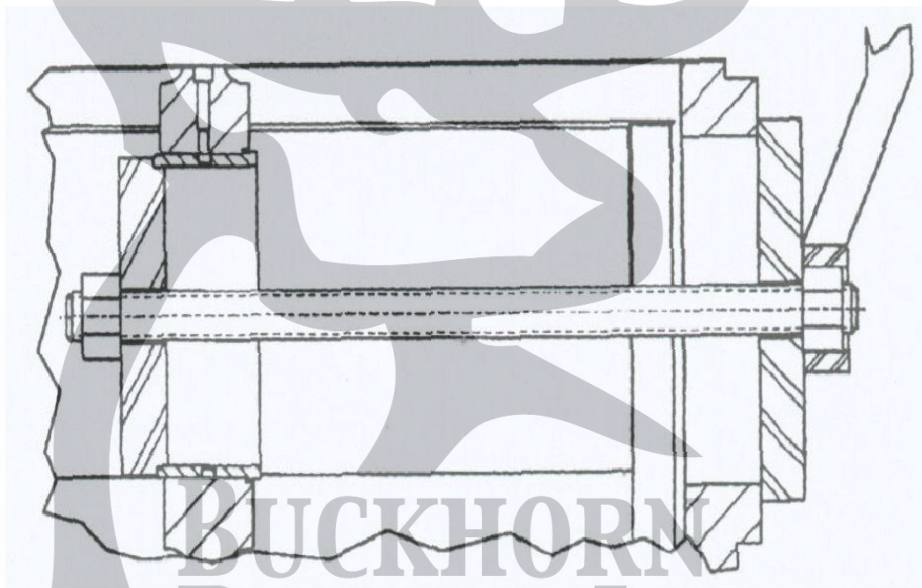

Figure 22: Center Bearing Puller

11. Bearing cones (13) may be removed from the crankshaft using an automotive type bearing puller or cutting torch. Bearing cups (12) can be removed from the bearing housing using a puller if a sufficient lip is available for the puller arms to grab. An alternate procedure involves running a weld bead around the inside surface of the cup. When cool, this will reduce the interference between the cup and bearing housing enough to free the cup. If either the cup or cone is replaced, the corresponding cup or cone should be replaced as they are a matched set.



12. Mark each connecting rod and crosshead assembly with a unique number and mark the corresponding bores (do not mark the machined ID surface of the bore) in the power frame to match to insure they are reassembled into the same bore from which they were removed. Pull the connecting rod/crosshead assemblies from the power frame.

BUCKHORN  
PUMPS, INC.



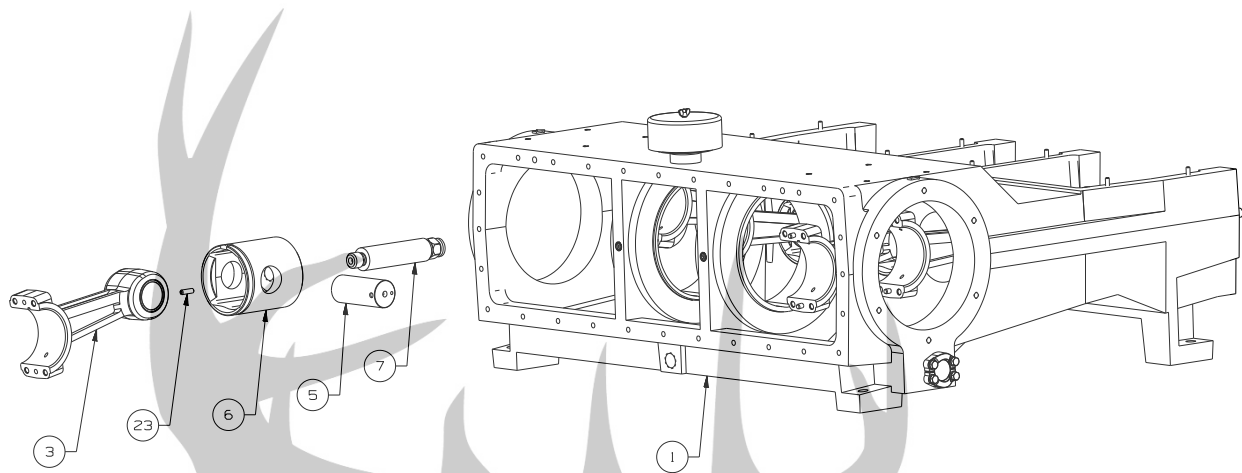

Figure 23: Plunger (Pony) Rod and Crosshead Removal

13. Remove the set screws (23) and slide the wrist pin (5) out of the crosshead (6) if crosshead or connecting rod (3) requires service. Keep components matched together.
14. Inspect all components for signs of wear or damage and replace if required. Carefully check the crankshaft bearing surfaces for pits, scratches, or other signs of wear. The connecting rod bearings should be inspected for deep scratches or the top metal surface worn away.
15. If damaged, remove the crankshaft oil seal (27) using a screwdriver or similar object and discard the old seal.
16. Thoroughly clean all parts with solvent and apply a thin coat of oil before reassembly.

17. Tapered roller bearing cones (13) must be heated to aid in assembly onto the crankshaft. Always observe proper safety procedures and use heat resistant tools and gloves when handling hot parts. There a number of recommended methods for heating bearings. Electric ovens or electrically heated oil baths may be used, but only when accompanied by proper thermostatic control.
18. To replace the tapered roller bearings on the crankshaft, heat the bearing cones to a maximum of 300° F (149° C). Slide them down the shaft until they are fully seated against the shoulder. The hot cone may pull away from the shoulder unless it is held in position until it cools enough to grab the shaft. Use a .001" thick feeler gauge to insure the cone is fully seated against the shoulder after parts have cooled.
19. Use a press to seat the new cups (12) into the bearing housings. Never use new bearing cones with old bearing cups. Always use matched sets from one manufacturer. Installation Tip: The bearing cup can be placed in a freezer at 20° F (-7° C) or colder for at least 30 minutes to shrink the part enough to allow easier installation.
20. Reassemble the crosshead assemblies and connecting rods. Match the marked connecting rod and crosshead back together. Be sure to align the oil slot in the crosshead with the oil pocket in the connecting rod. Insure that the set screws (23) retaining the wrist pins (5) are in place (if they were removed for repair or inspection of the wrist pin bushing). The set screw must engage the flat on the wrist pin. Apply a thread locking compound to insure that it will remain tight. Refer to Section 11.0 for torque specifications.
21. Push the crosshead/connecting rod assemblies fully forward in power frame to provide maximum clearance for the crankshaft. Insure crosshead assemblies are replaced in the same orientation and in the same cylinder bore they were originally.

**NOTE: The oil cup pocket feeding lubricant to the wrist pin bushing is on the top of the connecting rod and should be in the up position.**

22. Install crankshaft in the power frame. It is recommended that two people be available for crankshaft installation due to the size and weight. A hoist and counterbalance lifting device should be used if possible. Take care not to scratch bearing surfaces of the crankshaft or the center support bearings.
23. Inspect the gaskets (9) that seal the bearing housing and replace if damaged. Reinstall the shims (10) and bearing housings (8). As a starting point, install the same number of shims that the pump originally had prior to service work. When tightening the fasteners retaining the bearing cover, use crisscross pattern for tightening with a torque wrench.
24. Reinstall or replace the rod bearings (16) in the connecting rod and connecting rod caps per instructions in section 10.4.2. Insure that rod caps are properly assembled with their mating connecting rod. Use back and forth pattern tightening with a torque wrench.

25. A dial indicator must be used to properly adjust the endplay of the crankshaft. Improper adjustment may result in excessive temperature, noise, and reduced bearing life. FMC recommends between .005 inches (0.13 mm) tight to .002 inches (0.05 mm) loose of internal axial clearance (end play) when properly assembled. The final adjustment must be verified using a dial indicator as shown in the following steps 25 through 29.
26. Turn the crankshaft (2) more than two revolutions to insure the connecting rods (3) are loose and that there is no binding in the rod bearings (16); the wrist pin (5) joints are free; and the crossheads move freely in the power frame.

27. Move the crankshaft to one side of the power frame using a light tap from a rubber mallet or a pry bar. Rotate the crankshaft several turns and repeat the light taps from a rubber mallet or the use of a pry bar to insure the crankshaft is to one side.



28. Mount indicator base on the power frame with the indicator tip on a machined shoulder surface of the crankshaft (do not measure from a cast surface) and the axis of the indicator parallel to the crankshaft.



29. Set the dial indicator to zero.

30. Move the crankshaft back over to the opposite side and read bearing endplay as total indicator movement. Rotate the crankshaft several turns and repeat the effort to move the crankshaft in the direction described in this step. Repeat the dial indicator measurement. Remove or add shims as necessary to achieve proper endplay (.005 inches tight to .002 inches loose). Distribute shims equally on both bearing housings. Verify the endplay with the dial indicator per this procedure described before final assembly.



31. Install the oil seal (27) into the bearing housing. The oil seal can be installed with light hammer blows. When properly seated it will be flush with the face of the bearing housing.
32. NOTE: Pumps fitted with direct crankshaft driven oil pumps have a seal on the crankshaft extension inside the bearing housing that is not visible. Refer to Figure 24 for a detail of this configuration. This is a mechanical seal that has components made of very hard and brittle materials and can be easily damaged if dropped or struck by other objects. It is better to install this mechanical seal after the crankshaft is in place. This is performed by pushing the larger element, with the external o-ring, into the bronze bushing in the bearing housing. The polished face must be away from the flange of the bronze bushing. Install the smaller element, with the internal o-ring, onto the crankshaft extension with the polished carbon face against the polished face of the larger element. The magnetic attraction and the oil pressure hold the seal components in place.

PUMPS, INC.

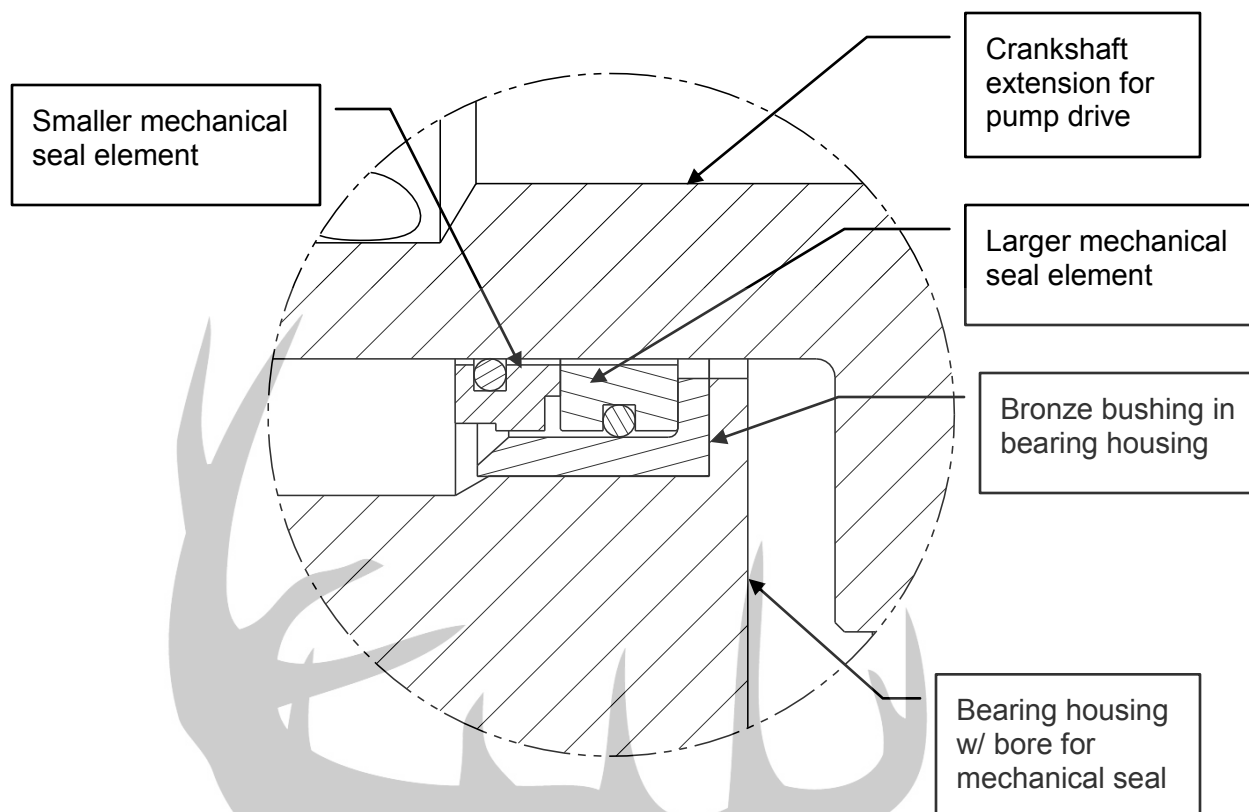

Figure 24: Direct Crankshaft Driven Pump Seal

33. Install the seal housing (19) in the power frame per instructions in section 10.4.1. The crankshaft should turn freely.
34. Complete reassembly of pump.
35. Torque all fasteners as outlined in Fastener Torque Requirements, Section 11.0 of this manual.

## 11.0 Fastener Torque Requirements

NOTICE: No pump service procedure is complete without insuring that the fasteners have been properly torqued. Failure to properly tighten the pump bolts could cause the pump to leak or possibly cause the pump to fail. Always use a calibrated torque wrench during the installation of all critical fasteners listed in Table 4 below. Values are in foot-pounds (Ft-lb) and Newton meters (N-m). Typical sizes are shown in Table 5 below. Xylan coated fasteners can be identified by a blue or black polymer coating.

POWER END							
Item No.	Component Description	Q16			Q18		
		Size	Ft-lb	(N-m)	Size	Ft-lb	(N-m)
3	Connecting Rod Bolts	0.625	120	163	0.500	60	81
16	Seal Housing Screw	0.375	25	34	0.375	25	34
18	Bearing Housing Bolts	0.500	60	81	0.500	60	81
19	Back Cover Bolts	0.500	30	41	0.500	30	41
20	Cross Head Set Screw	0.375	25	34	0.375	25	34

FLUID END							
Item No.	Component Description	Q16			Q18		
		Size	Ft-lb	(N-m)	Size	Ft-lb	(N-m)
14	Plunger Clamp Screw	0.375	25	34	0.375	25	34
50	Cyl. Attachment Nut *	1.000	480	651	1.000	480	651
51	Valve Cover Nut *	0.750	200	271	0.750	200	271
51	Valve Cover Nut *	1.000	480	651	1.000	480	651
51	Valve Cover Nut *	1.125	680	922	1.125	680	922
52	Stuffing Box Clamp Nut *	0.750	200	271	0.750	200	271
52	Stuffing Box Clamp Nut *	0.875	320	434	0.875	320	434

\* For XYLAN (Blue or Black polymer) coated studs and nuts use the following table:

SIZE	0.375	0.500	0.625	0.750	0.875	1.000	1.125	1.250
Ft-lb	25	40	80	135	215	320	460	630
(N-m)	34	54	108	183	292	434	624	854

Refer to Figure 3 and Figure 4 for item numbers.

Table 5: Torque Values for Critical Pump Fasteners

## 12.0 Critical Clearances

When maintenance requiring disassembly of the power end is performed, the following clearances should be checked to see if they are within factory specification or within maximum allowable limits. Additional clearance is allowed for component wear. This additional clearance is a maximum of .002 inches (0.05 mm) of total diametric wear that can be added to the clearance values in Table 6. For radial clearance, use ½ of the total diametric value.

All dimensions are shown in Inches.

DESCRIPTION	Q16	Q18
Crankshaft Throw Diameter (Stroke)	4.00	4.50
Crankshaft Pin or Journal (OD)	4.4965/4.4975	4.4965/4.4975
Connecting Rod/Crank Clearance (Max. Total)	0.004	0.004
Crosshead Diameter (OD)	4.997/4.999	5.747/5.748
Crosshead Cylinder Bore (ID)	5.0015/5.0045	5.7515/5.7545
Crosshead to Bore Clearance (Max. Total)	0.0075	0.0075
Wrist Pin Bushing Bore (ID)	1.753/1.754	2.253/2.254
Wrist Pin to Bore Clearance (Max. Total)	0.0046	0.002
Crankshaft Center Bearing (O.D.)	8.9985/8.9995	9.499/9.500
Crankshaft Center Bearing Bushing ID	9.0115/9.0105	9.5120/9.5110
Center Bearing Clearance (Max. Total)	0.013	0.013

NOTE: Clearances shown are total diametric values: For radial clearance use ½ the value shown.

Table 6: Clearance Chart

Metric Conversion:      1 inch = 25.4 mm  
                                     1 mm = 0.03937 inches  
                                     25 µm (micrometers) = 0.001 inches

### 13.0 Valve Removal and Installation Tools

Table 7 shows the FMC part numbers for valve removal tools for the various AR valves used in the models specified.

Table 8 on the following page shows the FMC part numbers for valve removal and installation tools for the various Disc valves used.

Q16 SIZE PUMPS			
VALVE TYPE	VALVE ASSY	VALVE SIZE	REMOVAL TOOL
AR	3263921& 3263922	Series 3	P503030
AR	P533621 & P533626	Series 23	P503030
AR	5271408, P517031 &P526773	Series 7	5276358
AR	P533509 & P533514	Series 27	5276358
AR	5271407 & P515117	Series 8	5276358
AR	5271071, 5271072, P508799 & P508800	Series 11	5276359
AR	P534472 & P534473	Series 211	5276359
Q18 SIZE PUMPS			
VALVE TYPE	VALVE ASSY	VALVE SIZE	REMOVAL TOOL
AR	5271408	Series 7	5276358
AR	P533509 & P533514	Series 27	5276358
AR	5271407, P515117 & P515118	Series 8	5276358
AR	5271071, 5271072, P508799 & P508800	Series 11	5276359
AR	P534472 & P534473	Series 1211	5276359

Table 7: AR Valve Removal Tool Guide

Q16 SIZE PUMPS			
VALVE TYPE	VALVE ASSY	VALVE SIZE	REMOVAL TOOL
Disc	5277100 & P506942	Series 7	3268171
Disc	5277101 & P506946	Series 8	3268171
Disc	3264150, 3264151, 5277098 & 5277099	Series 11	P511484
Q18 SIZE PUMPS			
VALVE TYPE	VALVE ASSY	VALVE SIZE	REMOVAL TOOL
Disc	5277100	Series 7	3268171
Disc	5277101	Series 8	3268171
Disc	P514264 & P514265	Series 9	3268171
Disc	3264150, 3264151, 5277098 & 5277099	Series 11	P511484

Table 8: Disc Valve Removal Tool Guide



## 14.0 Trouble-Shooting Pumps

This chart is designed to aid in the solution of pump and pump system problems. Once the problem has been identified, work through the possible causes and solutions until the problem has been corrected.

SYMPTOM	POSSIBLE CAUSE	REMEDY
No flow from pump	<ul style="list-style-type: none"> <li>-No liquid in reservoir (tank)</li> <li>-Inlet line valve closed</li> <li>-Inlet strainer is totally clogged with debris</li> <li>-Crankshaft is not turning</li> </ul>	<ul style="list-style-type: none"> <li>-Insure lines are connected and fill tank</li> <li>-Insure lines are connected and open valve</li> <li>-Clean or replace strainer</li> <li>-Check for power to drive and drive connections</li> </ul>
Insufficient pressure from pump (ONLY)	<ul style="list-style-type: none"> <li>-Pump speed is too low</li> <li>-Relief valve improperly adjusted or worn</li> <li>-Insufficient system resistance (worn nozzle)</li> <li>-Worn check valves</li> <li>-Excessive leakage from pump seals</li> </ul>	<ul style="list-style-type: none"> <li>-Check belt tightness or power to motor</li> <li>-Check relief valve and adjust setting</li> <li>-Properly service system</li> <li>-Inspect check valves and repair or replace</li> <li>-Adjust or replace packing or damaged parts</li> </ul>
Insufficient flow from pump (ONLY)	<ul style="list-style-type: none"> <li>-Pump speed is too low</li> <li>-Relief valve improperly adjusted or worn</li> <li>-Worn pump valves</li> <li>-Excessive leakage from pump seals</li> <li>-Plunger or piston worn</li> <li>-Valve seat washed out in fluid cylinder</li> </ul>	<ul style="list-style-type: none"> <li>-Check belt tightness or power to motor</li> <li>-Check relief valve and adjust setting</li> <li>-Inspect pump valves and repair or replace</li> <li>-Adjust or replace packing or damaged parts</li> <li>-Replace plunger or piston</li> <li>-Repair or replace fluid cylinder</li> </ul>
Insufficient flow or pressure AND rough operation (pump pounds or vibrates)	<ul style="list-style-type: none"> <li>-All pump cylinders not primed</li> <li>-By-pass or relief is piped back to suction</li> <li>-Inlet line too long or too small in diameter</li> <li>-Insufficient NPSHA</li> <li>-Air leaks in suction line or fittings</li> <li>-Vortex in tank near inlet pipe opening</li> <li>-Air entering booster pump</li> <li>-Pump valve stuck open or closed</li> <li>-Valve assembly damaged or unseated</li> <li>-Valve seat washed out in fluid cylinder</li> <li>-Gas pocket formation from high spots in suction</li> </ul>	<ul style="list-style-type: none"> <li>-Prime all chambers</li> <li>-Pipe back to reservoir (tank)</li> <li>-Increase suction pipe size</li> <li>-Provide more NPSH</li> <li>-Correct installation to stop leaks</li> <li>-Increase submergence or baffle to stop vortex</li> <li>-Correct installation of booster pump</li> <li>-Clean and deburr valve</li> <li>-Properly seat or repair valve</li> <li>-Repair or replace fluid cylinder</li> <li>-Correct suction line installation</li> </ul>

<p>Pump runs rough, knocks, or vibrates (ONLY)</p>	<ul style="list-style-type: none"> <li>-Broken or weak valve spring</li> <li>-Valve damaged or unseated</li> <li>-Loose plunger, piston, or rod</li> <li>-Low oil level in power end</li> <li>-Excessive connecting rod bearing clearance</li> <li>-Excessive main bearing clearance</li> <li>-Worn wrist pin or bearing</li> <li>-Pump running backward</li> <li>-Loose sheaves or bushings (v-belt drive)</li> <li>-Gear tooth cracked or broken</li> <li>-Insufficient NPSHA</li> <li>-Excessive acceleration head in suction line</li> <li>-Pulsation dampener improperly charged</li> <li>-Inlet line too long or too small in diameter</li> <li>-Worn piston seal allows air ingress (usually observed when booster not used)</li> </ul>	<ul style="list-style-type: none"> <li>-Replace valve spring</li> <li>-Repair/replace valve or re-seat</li> <li>-Tighten loose components</li> <li>-Fill to proper level</li> <li>-Check cap torque or replace bearings</li> <li>-Adjust end-play</li> <li>-Replace worn components</li> <li>-Correct rotation</li> <li>-Tighten loose components</li> <li>-Replace gear</li> <li>-Provide more NPSH</li> <li>-Install suction stabilizer</li> <li>-Charge to proper pressure</li> <li>-Increase suction pipe size</li> <li>-Replace piston seal</li> </ul>
<p>Rapid suction pressure fluctuation</p>	<ul style="list-style-type: none"> <li>-Pump cavitation</li> <li>-Air is entering suction line</li> </ul>	<ul style="list-style-type: none"> <li>-Increase suction size or NPSH</li> <li>-Correct installation to stop leaks</li> </ul>
<p>Piping vibration</p>	<ul style="list-style-type: none"> <li>-Same as Pump runs rough above</li> <li>-Excessive pressure variation in discharge</li> <li>-Piping inadequately supported</li> <li>-Excessive short-radius elbows or tees</li> </ul>	<ul style="list-style-type: none"> <li>-See above</li> <li>-Install discharge pulsation dampener</li> <li>-Install supports at proper locations</li> <li>-Correct installation to minimize turns and short-radius fittings</li> </ul>
<p>Pump requires excessive power</p>	<ul style="list-style-type: none"> <li>-Discharge pressure too high</li> <li>-Plungers or pistons too large</li> <li>-Speed too high</li> <li>-Packing too tight</li> <li>-Misaligned coupling</li> <li>-Belts too tight</li> <li>-Power end bearings too tight</li> <li>-Low motor voltage</li> </ul>	<ul style="list-style-type: none"> <li>-Reduce system back-pressure or relief valve</li> <li>-Install smaller plungers to reduce flow</li> <li>-Reduce speed</li> <li>-Loosen gland (Adjustable packing)</li> <li>-Correct alignment</li> <li>-Correctly adjust belt tension</li> <li>-Increase end-play</li> <li>-Supply correct voltage</li> </ul>
<p>Power end overheats (over 170° F) and/or reduced power end component life</p>	<ul style="list-style-type: none"> <li>-Discharge and/or suction pressure too high</li> <li>-Oil level too high or too low</li> <li>-Contaminated power end oil</li> <li>-Incorrect oil viscosity or grade</li> <li>-Misaligned coupling</li> <li>-Belts too tight</li> <li>-Pump running backward</li> <li>-Pump located too close to heat source</li> <li>-Worn or damaged power end bearings</li> </ul>	<ul style="list-style-type: none"> <li>-Reduce pressure or reduce plunger size</li> <li>-Adjust to correct oil level</li> <li>-Refill with clean oil &amp; eliminate contamination</li> <li>-Fill with correct oil</li> <li>-Correct alignment</li> <li>-Correctly adjust belt tension</li> <li>-Correct rotation</li> <li>-Remove heat source or insulate power end</li> <li>-Replace damaged bearings</li> </ul>
<p>Crankshaft jerks or starts and stops rotation</p>	<ul style="list-style-type: none"> <li>-Drive belts loose and slipping (if equipped)</li> <li>-System relief valve pressure set too high</li> <li>-Discharge line blocked or partially blocked</li> </ul>	<ul style="list-style-type: none"> <li>-Correctly adjust belt tension</li> <li>-Reduce relief valve pressure setting</li> <li>-Clear obstructions from piping system</li> </ul>

Fluid leaking from pump	<ul style="list-style-type: none"> <li>-Packing or piston cups are worn</li> <li>-Piston to rod o-ring damaged</li> <li>-Fluid cylinder bolts not properly tightened</li> <li>-Fluid cylinder o-rings (or gaskets) damaged</li> </ul>	<ul style="list-style-type: none"> <li>-Replace packing or piston cup</li> <li>-Replace o-ring</li> <li>-Properly tighten and torque bolts</li> <li>-Replace damaged o-rings or gaskets</li> </ul>
Reduced packing or piston cup life	<ul style="list-style-type: none"> <li>-Highly abrasive particles in fluid</li> <li>-Packing or piston cups run dry</li> <li>-Incorrect packing or cups for fluid type</li> <li>-Inadequate packing lubrication</li> <li>-Pump was run dry for extended time</li> <li>-Plunger (or rod) misaligned to stuffing box</li> <li>-Worn plunger or cup holder</li> <li>-Worn cylinder liner bore</li> <li>-Packing gland too tight (adjustable)</li> <li>-Packing gland too loose (adjustable)</li> <li>-Too much packing in box</li> <li>-Broken or weak spring</li> </ul>	<ul style="list-style-type: none"> <li>-Install strainer or filter</li> <li>-Correct problem &amp; replace packing or cup</li> <li>-Change to correct packing or cup</li> <li>-Correct problem and replace packing</li> <li>-Correct problem and replace cups</li> <li>-Correct alignment</li> <li>-Replace plunger or cup holder</li> <li>-Replace cylinder liner</li> <li>-Properly adjust gland nut</li> <li>-Properly adjust gland nut</li> <li>-Correct installation problem</li> <li>-Replace spring</li> </ul>
Reduced valve life	<ul style="list-style-type: none"> <li>-Highly abrasive particles in fluid</li> <li>-Cavitation damage</li> <li>-Air leaking into suction line or stuffing box</li> <li>-Suction inlet insufficiently submerged</li> <li>-Relief valve or bypass piped to suction</li> <li>-Valve damaged by improper installation</li> </ul>	<ul style="list-style-type: none"> <li>-Install strainer or filter</li> <li>-Correct problem and replace damaged valves</li> <li>-Correct problem and replace damaged valves</li> <li>-Increase submergence or baffle to stop vortex</li> <li>-Pipe back to reservoir (tank)</li> <li>-Replace damaged components</li> </ul>
Cracked fluid cylinder or broken fluid end bolts	<ul style="list-style-type: none"> <li>-Discharge pressure too high</li> <li>-Hydraulic shock (cavitation or entrained air)</li> <li>-Discharge valve stuck closed</li> <li>-Fluid freezing in fluid cylinder</li> <li>-Material or manufacturing defect</li> <li>-Bolt or nut not properly torqued</li> <li>-excessive piping loads on fluid end</li> </ul>	<ul style="list-style-type: none"> <li>-Reduce system back pressure or relief valve</li> <li>-Correct piping system problem</li> <li>-Replace damaged components</li> <li>-Change procedure to drain fluid when cold</li> <li>-Replace defective component</li> <li>-Replace fluid cylinder and properly torque</li> <li>-Add supports to piping</li> </ul>
Broken crankshaft or connecting rod	<ul style="list-style-type: none"> <li>-Discharge pressure too high</li> <li>-Suction pressure too high</li> <li>-Fluid freezing in fluid end</li> <li>-Hydraulic shock due to cavitation</li> <li>-Material or manufacturing defect</li> </ul>	<ul style="list-style-type: none"> <li>-Reduce system back pressure or relief valve</li> <li>-Reduce suction pressure or plunger diameter</li> <li>-Change procedure to drain fluid when cold</li> <li>-Correct piping system problems</li> <li>-Replace defective components</li> </ul>
Power end oil is contaminated	<ul style="list-style-type: none"> <li>-Extended operation with failed packing</li> <li>-Hi-press wash wand near breather or seals</li> <li>-Deflector shields are missing or damaged</li> <li>-Crosshead extension seals damaged</li> <li>-Excessive capacity in liner wash system</li> <li>-Improperly adjusted liner wash nozzle</li> <li>-Too long between oil changes</li> </ul>	<ul style="list-style-type: none"> <li>-Replace packing and improve monitoring</li> <li>-Provide shields to protect breather and seals</li> <li>-Repair or replace deflector shields</li> <li>-Replace oil seals</li> <li>-Reduce capacity in liner wash system</li> <li>-Adjust liner wash nozzle</li> <li>-Change oil</li> </ul>

## 15.0 Ordering Parts

Service parts are available through FMC's worldwide network of distributors or from the original supplier for the equipment that the pump is a component of. If unsure where to purchase parts, contact FMC customer service for the location of an authorized parts retailer in your area.

Always insist on genuine FMC replacement parts.

Use the assembly drawing and bill of material included with this manual to determine the components and corresponding part numbers required to service the pump. Make sure that the part number on the drawing or bill of material matches the part number of the pump requiring parts.

When ordering parts, always reference the part number and serial number of the pump with the order. These numbers can be found stamped on the metal name tag affixed to the power end of every pump. By referencing these numbers you can insure that the components you receive work as intended with your pump.

Be sure to inquire about any special service tools or complete maintenance kits.



BUCKHORN  
PUMPS, INC.

## 16.0 Glossary of Commonly Used Terms

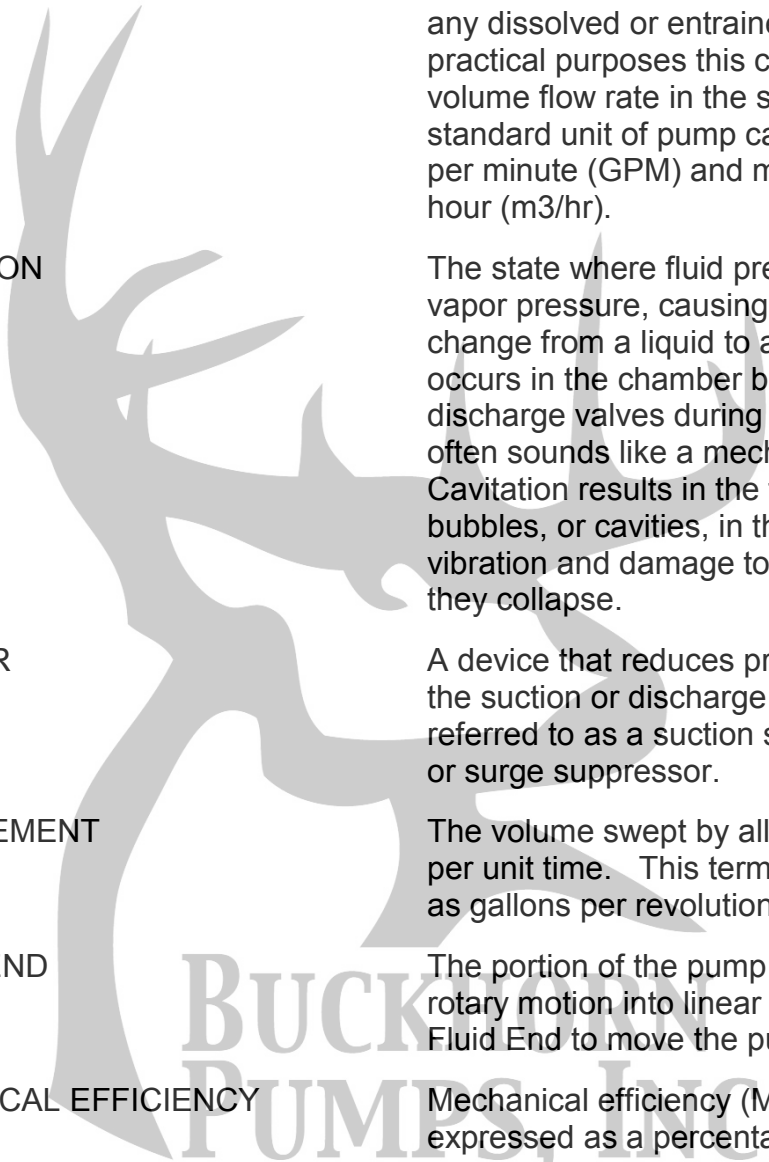

CAPACITY	The total volume throughput per unit of time at suction conditions. It includes both liquid and any dissolved or entrained gases. For all practical purposes this can be considered the volume flow rate in the suction pipe. The standard unit of pump capacity is U.S. gallons per minute (GPM) and metric cubic meters per hour (m <sup>3</sup> /hr).
CAVITATION	The state where fluid pressure drops below vapor pressure, causing the liquid to begin to change from a liquid to a gas and boil. Usually occurs in the chamber between the suction and discharge valves during the suction stroke, and often sounds like a mechanical knock. Cavitation results in the formation of gas bubbles, or cavities, in the fluid that cause vibration and damage to components when they collapse.
DAMPNER	A device that reduces pressure pulsations in the suction or discharge piping. This may be referred to as a suction stabilizer, accumulator, or surge suppressor.
DISPLACEMENT	The volume swept by all pistons or plungers per unit time. This term is typically expressed as gallons per revolution.
POWER END	The portion of the pump that converts supplied rotary motion into linear motion used by the Fluid End to move the pumpage.
MECHANICAL EFFICIENCY	Mechanical efficiency (ME) is the ratio, expressed as a percentage, of pump power output to the pump power input. The mechanical efficiency of reciprocating pumps is very high, typically 85% to 90%.
VOLUMETRIC EFFICIENCY	Volumetric efficiency (VE) is the ratio of actual pump capacity output to theoretical displacement. The volumetric efficiency is

affected by the fluid being pumped and the discharge pressure.

**FLOODED SUCTION**

Implies that the level of liquid in the suction vessel is above the centerline of the suction port of the pump.

**FLUID END**

The portion of the pump that converts the linear motion supplied by the power end into fluid flow at pressure. This may also be called the Liquid End. It is called a valve chamber in old literature.

**NPSHa**

An abbreviation that stands for Net Positive Suction Head Available. NPSHA is the total suction pressure, including allowance for acceleration head, available from the system at the pump suction connection, minus the vapor pressure of the liquid at actual pumping temperature. NPSHA for a reciprocating pump is normally expressed in units of feet of water.

**NPSHr**

An abbreviation that stands for "Net Positive Suction Head Required". This is the minimum total inlet pressure required by the pump for proper operation. This value is a function of pump design and speed and is determined by the pump manufacturer through a specific NPSH test. NPSHR should exceed NPSHA by at least 5 feet.

**PISTON**

A type of power pump that uses a cylindrical seal (piston) mounted on a holder to drive fluid through the valves. The piston seal reciprocates within a stationary cylinder.

**PLUNGER**

A type of power pump that uses a cylindrical plunger to drive fluid through the valves. The plunger reciprocates through a stationary set of seals known as packing.

**POWER PUMP**

A reciprocating pump that drives the pumping element(s) using a slider crank mechanism. Power pumps are piston, plunger, or diaphragm type. All require a driver with a rotating shaft, such as a motor or engine, as a power source.

**POWER FRAME**

The major portion of a power pump that encloses and supports all other components of the power (or drive) end. It is called a pump case in old literature.

**STROKE LENGTH**

The length of one complete, unidirectional motion of the piston or plunger. Stroke length is usually expressed in inches.

**PUMP VALVE**

A check valve that allows flow of liquid in one direction. FMC pumps have a series of two valves, one suction (inlet) and one discharge, per pumping cylinder.



## 17.0 Reference Information

Use the following section to record key information about your specific pump model. Information such as part and serial numbers will be needed when ordering service parts. This data may be found stamped on the metal nameplate located on the pump power frame. This area may also be used to make notations about special parts, procedures, phone numbers, or other important information related to your pump.

Pump Model \_\_\_\_\_

Part Number \_\_\_\_\_

Serial Number \_\_\_\_\_

Rated Pressure \_\_\_\_\_

Rated Capacity \_\_\_\_\_

Rated Speed \_\_\_\_\_

Notes:

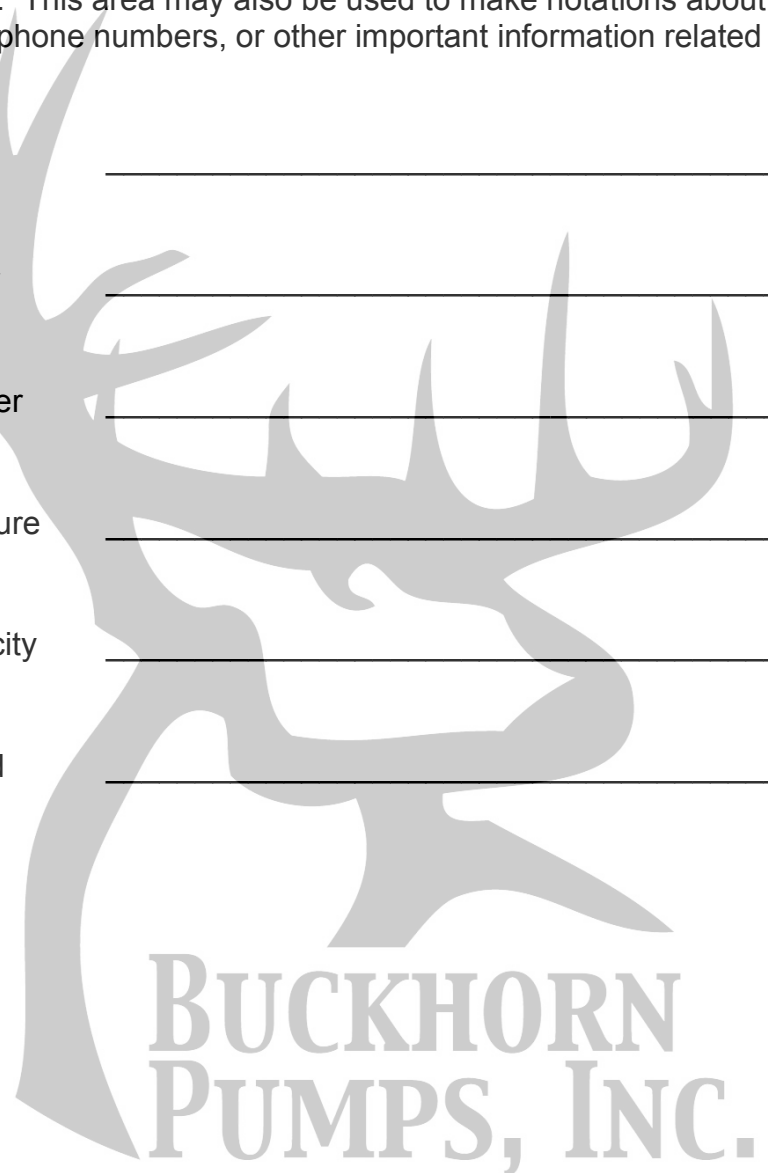





## 18.2 Checklist for Starting a Pump

	<p>1. Insure that the drain plug(s) on the bottom of the pump crankcase have been installed and are tight. Insure that the oil level sight glass, if equipped, has been properly installed.</p>
	<p>2. Check the oil level to insure that the pump is properly filled and that the oil has not been contaminated with water or other contaminants. NOTE: FMC pumps are shipped with no oil in the power frame and must be filled to the proper level with the proper grade of oil prior to start-up. Use the Table 3 provided in Section 6.0 for selecting the correct type of oil for your service.</p>
	<p>3. Check the plunger rods to insure that they are free from abrasive particles or debris. Apply a light oil film to the plunger rods before start up.</p>
	<p>4. Insure that the pressure relief valve and all accessory equipment have been installed and properly adjusted. Verify that all joints are pressure tight.</p>
	<p>5. Open the suction line valve to allow fluid to enter pump. Prime the fluid cylinder if necessary on the initial start up or after the system piping has been drained. The valve covers may have to be cracked open to assist with priming. CAUTION: Do not loosen the valve covers with volatile or hazardous fluids.</p>
	<p>6. Check to insure that power is locked out and tagged out. Turn the pump over by hand if possible to insure free, unobstructed operation. Clean the plungers with a soft cloth while rotating the pump by hand.</p>
	<p>7. Apply small amounts of glycerin to the plungers and plunger rods to lubricate the packing and seals.</p>
	<p>8. Make sure that all guards are in place and secure. Verify that all personnel are in safe positions and that system conditions are acceptable for operation.</p>
	<p>9. The pump is now ready to start. NOTICE: Whenever possible, use a bypass line for the flow to allow the pump to start in an unloaded condition (no discharge pressure). Slowly close the bypass line to bring the pump into full load conditions. Shut down immediately if the flow becomes unsteady, pressure fluctuates, or if unusual sounds or vibrations are noted. Insure that pump rotation is correct.</p>