

**OPERATION AND MAINTENANCE MANUAL, L06 THROUGH L16  
TRIPLEX PUMPS**

Rev	ECN No.	Date	Reviewed By	Approved By	Status
G	5035067	29-MAY-2014	Ruvalcaba, Mario	McClain, Mathew	RELEASED

**Summary:**

This is a manual for L06 through L16 triplex piston pumps. These pumps include direct drive (no pinion shaft) or pinion drive (for internal gear reduction); they have a stroke length ranging from 1.50 to 4.00 inches and power ratings from 10 horsepower (7.5 kilowatts) to 105 horsepower (78 kilowatts). Refer to part number [P514112](#) for printing information.

**BUCKHORN  
PUMPS, INC.**

## Table of Contents

<b>1.0</b>	<b>Important Safety Instructions .....</b>	<b>5</b>
<b>2.0</b>	<b>L06 – L16 Pump Features .....</b>	<b>6</b>
<b>3.0</b>	<b>Storage Instructions .....</b>	<b>8</b>
3.1	Short Term Storage .....	8
3.2	Short Term Storage for Severe Environments .....	8
3.3	Long Term Storage .....	8
3.4	Returning a Stored Pump to Operation .....	9
3.5	Precautions during Freezing Weather .....	9
<b>4.0</b>	<b>Installation Guidelines .....</b>	<b>10</b>
4.1	General Location .....	10
4.2	Mounting Pump to Foundation and Power Source .....	10
4.3	Bearingless Hydraulic Motor Drives .....	11
4.4	Suction Piping Recommendations .....	11
4.5	Discharge Piping Recommendations .....	12
4.6	Multiple Pump Systems .....	13
<b>5.0</b>	<b>How to Start a Pump .....</b>	<b>14</b>
<b>6.0</b>	<b>Lubrication of Power End .....</b>	<b>15</b>
6.1	Recommended Lubricants .....	15
6.2	Oil Changes .....	16
<b>7.0</b>	<b>Inspection and Preventative Maintenance Chart .....</b>	<b>17</b>
<b>8.0</b>	<b>Estimated Life of Wearing Components .....</b>	<b>19</b>
<b>9.0</b>	<b>Component Parts List .....</b>	<b>20</b>
<b>10.0</b>	<b>Service Procedures .....</b>	<b>24</b>
10.1	Replacing Piston Cups .....	24
10.2	Removing the Fluid Cylinder .....	28
10.3	Replacing Valves .....	30
10.3.1	Replacing AR Valves .....	32
10.3.1.1	Introduction .....	32
10.3.1.2	Knock Out Tool .....	33
10.3.1.3	Valve Cage Removal For Eccentric Disc Method .....	35
10.3.1.4	Eccentric Disc .....	36
10.3.1.5	Threaded Type (AR Valves Only) .....	39
10.3.1.6	Installation of AR Valves .....	40
10.3.1.6.1	Installing Smaller, Factory Torqued AR Valves .....	40
10.3.1.6.2	Installing Larger, Non-Factory Torqued AR Valves .....	41
10.3.2	Replacing L Series Disc Type Valves .....	42
10.3.2.1	Introduction .....	42
10.3.2.2	Valve Removal Tools .....	43
10.3.2.3	Installation of Disc Valves .....	43
10.4	Servicing the Power End .....	45
10.4.1	Replacing Piston Rod Oil Seals .....	45
10.4.2	Replacing Power End Bearings & Crankshaft .....	47

**11.0 Fastener Torque Requirements ..... 55**  
**12.0 Critical Clearances ..... 57**  
**13.0 Valve Removal and Installation Tools ..... 58**  
**14.0 Trouble-Shooting Pumps ..... 60**  
**15.0 Ordering Parts ..... 63**  
**16.0 Glossary of Commonly Used Terms ..... 64**  
**17.0 Reference Information ..... 67**  
**18.0 MAINTENANCE LOG ..... 68**



## List of Figures

Figure 1: L11-L16 Pump Assembly with Pinion Shaft.....	6
Figure 2: L06 – L16 Pump Assembly with No Pinion Shaft (Includes HD & HV).....	7
Figure 3: Power End Components.....	20
Figure 4: Fluid End Components.....	21
Figure 5: AR Valve Assembly.....	32
Figure 6: Using the Knock Out Tool.....	33
Figure 7: Removing the valve from the seat.....	34
Figure 8: Removing the valve from the fluid cylinder.....	34
Figure 9: Valve Disassembly.....	35
Figure 10: Eccentric Disc in Use.....	36
Figure 11: Removing the seat.....	37
Figure 12: Hydraulic Power used to Remove Valve Seat.....	38
Figure 13: Threaded Tool in Use.....	39
Figure 14: Typical L Series Disc Valve Assembly.....	42
Figure 15: Illustration of the P534694 and P534695 Ball Knock Out Tools.....	43
Figure 16. Identification of individual bolts for reference in torquing sequence.....	56

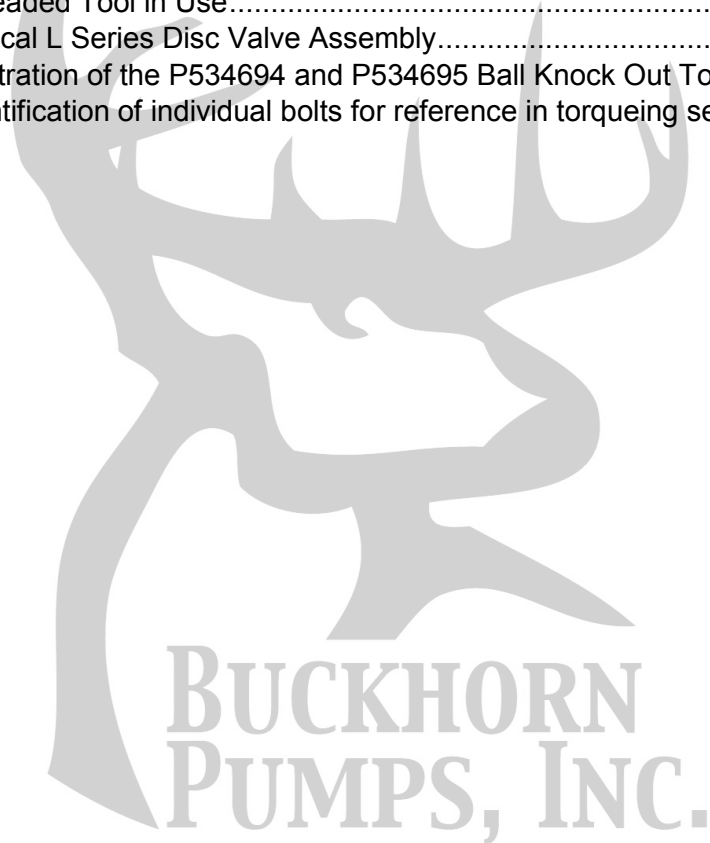

## 1.0 Important Safety Instructions



### WARNING

Many accidents occur every year through careless use of mechanical equipment. You can avoid hazards associated with high pressure equipment by always following the safety precautions listed below.

- **Shut down or disengage** the pump and all accessory equipment before attempting any type of service. Failure to do this could cause electrical shock or injury from moving pump parts or components under high pressure. Always adhere to "Lock Out" and "Tag Out" procedures. For mobile equipment, be sure engines and hydraulics cannot be accidentally started.
- **Bleed off all pressure** to the pump and piping before performing any maintenance on the pump. Failure to do so may spray water or chemicals at high pressure or high temperature onto service personnel.
- **Never operate the pump without a pressure relief valve**, rupture disc, or other type of properly sized over pressure safety device installed.
- **Always use a pressure gage** when operating the pump. The pressure must never exceed the maximum pressure rating of the pump or damage may occur. This damage can cause leakage or structural damage resulting in injury to personnel.
- **Ensure that no valves are placed between the pump and pressure relief valve.** If the pump is started with a closed or restricted valve in line before the pressure relief valve, the pump may exceed the rated or design pressure limits and rupture causing injury to personnel.
- **Use shields or covers around pumps** when pumping hot water, chemicals, or other hazardous liquids. This precaution can prevent the exposure of service personnel to these fluids should leakage occur.
- **Always use guards** on all belt drives, couplings, and shafts. Guards can prevent personnel from becoming entangled and injured or killed by rotating and reciprocating parts.
- **Use extreme caution with solvents** used to clean or degrease equipment. Most solvents are highly flammable and toxic. Observe all safety instructions on packaging.
- **Follow normal environmental guidelines** when fluids, lubricants, or solvents are disposed of or spilled.
- **Never modify the pump** to perform beyond its rated specifications without proper authorization in writing from FMC.

## 2.0 L06 – L16 Pump Features

Exceptional design, workmanship, materials, and over 100 years of pump building experience are features you'll find built into every FMC pump. The L Series pumps include the **Industrial Pumps** with an integral gear reduction pinion shaft, the **Horizontal Drill** (HD) configuration, and the **High Volume** (HV) configuration with abrasion resistant (AR) valves or ball valves for viscous fluids with stringy matter and with fluid ends designed for these valves.

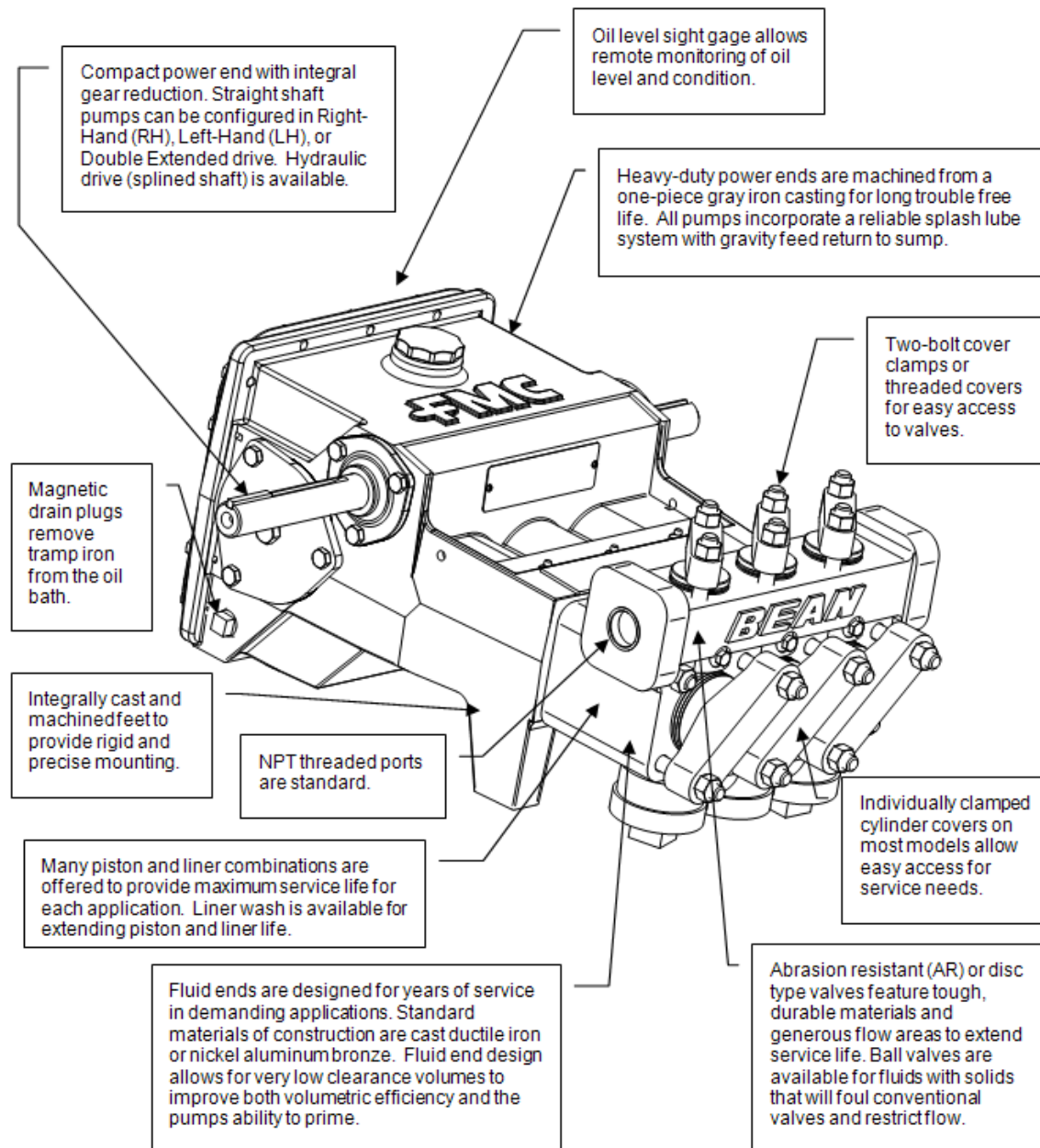

Figure 1: L11-L16 Pump Assembly with Pinion Shaft

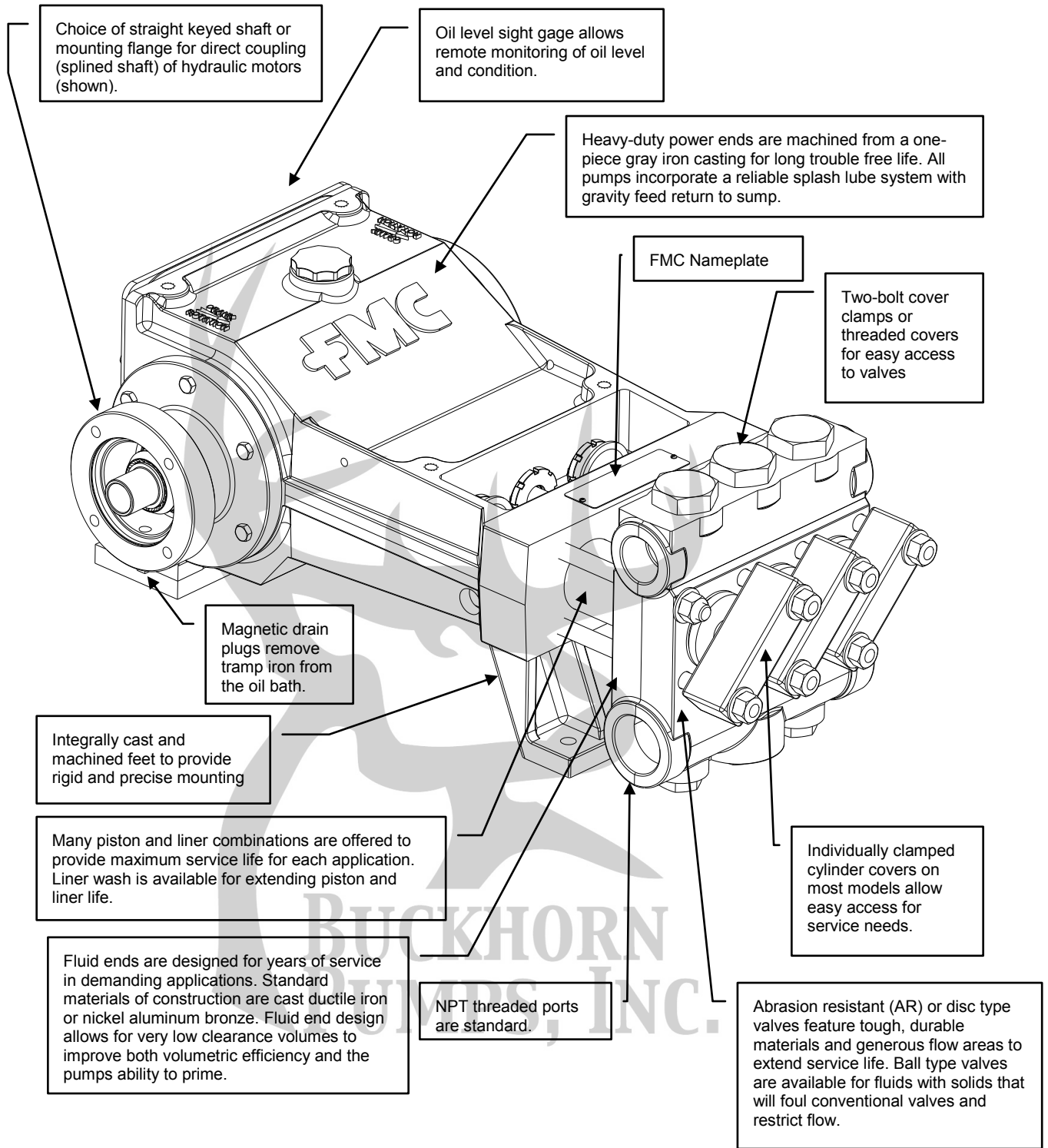

Figure 2: L06 – L16 Pump Assembly with No Pinion Shaft (Includes HD & HV)



## 3.0 Storage Instructions

Proper storage of your FMC pump will ensure that it is ready for service when needed. Follow the guidelines below that fit the requirements of your application.

**FMC pumps come from the factory without crankcase oil** and are prepared for storage periods of up to six months in proper environmental conditions. Indoor storage in a dry, temperature-controlled location is always recommended. If pumps are to be stored short term (less than six months) in a severe environment, they should be prepared using the procedures outlined in the "Short Term Storage for Severe Environments," Section 3.2 below. If the pump is to be stored, or is inactive, for periods in excess of six months, it is necessary to prepare the pump as outlined in the "Long Term Storage," Section 3.3. Remember that any fluid that poses an environmental hazard or is toxic must be handled and disposed of properly.

### 3.1 Short Term Storage

If the pump is stored in an indoor, temperature controlled environment for less than six months, no special steps are required to prepare it for storage. As a general rule for pumps in corrosive fluid applications, the fluid end should be drained, flushed with water or other non-corrosive cleanser and compressed air used to blow dry whenever idle.

### 3.2 Short Term Storage for Severe Environments

If the pump has been in service, drain any fluid from pump fluid end, flush the fluid end with water to clean out any of the remaining pumpage and blow dry with compressed air. Pour 1/4 to 1/2 cup of internal rust inhibitor oil described in Table 2 (see Recommended Lubricant Chart, Section 6.0), into the suction and discharge ports of fluid end, and then install pipe plugs in openings. Drain the power end (crankcase) oil and remove the oil fill cap (or plug). Pour 1/2 to 1 cup of internal rust inhibitor oil described in Table 2 into the oil fill hole then install the filler cap.

Coat all exposed, unpainted metal surfaces (for example, Driveshaft) with preservative oil. Replace the oil fill cap, and then cover the entire pump with a weather resistant covering such as a canvas or plastic tarp.

### 3.3 Long Term Storage

Long-term storage is defined as any period when the pump is in storage or idle longer than six months. If the pump has been in service, drain any fluid from the pump fluid end, flush the fluid end with water to clean out any of the remaining pumpage, and blow dry using compressed air. Pour 1/4 to 1/2 cup of internal rust inhibitor oil described in Table 2 into the suction and discharge ports of fluid end, and then install pipe plugs in openings. Remove the piston cups as described in Section 10.1 "Replacing Piston Cups" of this manual, seal them in a bag to protect against ozone, and store them in a



separate location with a controlled environment where they are protected from UV exposure.

Drain the oil from the pump power end. Remove the rear cover to expose the drive components. Spray all internal parts with a rust preservative that is soluble in lubricating oil while rotating the driveshaft several turns by hand to ensure complete coverage. Replace the rear cover and add ½ to 1 cup of internal rust inhibitor described in Table 2.

Remove the oil fill cap and store with the piston cup seals. Cap the breather opening with a plug or other suitable means in order to keep the preservative atmosphere sealed inside the power end. Spray a rust preventative onto all exterior machined surfaces paying attention to any unpainted areas like the crankshaft extension.

Never store the pump on the floor or ground. Always place it on a shelf or pallet that is several inches above ground level. Cover the entire pump with a canvas or plastic tarp. Every two months inspect the unit. Rotate the crankshaft by hand at least 4 turns during each inspection. Drain and replace the rust inhibitor after every six months of storage.

### **3.4 Returning a Stored Pump to Operation**

Before operating a pump that has been prepared for storage, drain the preservative and lubricating oil mixture from the power end (crankcase). If the pump has a pinion bearing, remove the rear cover and apply recommended crankcase lubricant (Refer to Table 2) to the pinion bearings. Reinstall the rear cover, drain plug, breather/filler cap, piston cup seals, and any other components that were removed for storage. Once these steps have been completed, follow the normal pump start up procedures outlined in this manual. NOTE: FMC can factory prepare units for long term storage for a nominal fee if specified at the time of order.

### **3.5 Precautions during Freezing Weather**

Freezing weather can cause problems for equipment when pumping water-based fluids that expand in volume when changing from a liquid to a frozen solid state. When water is left in a pump fluid end and exposed to freezing temperatures, the expansion of the water as it freezes can rupture the fluid cylinder of the pump and cause equipment damage. Injury may result when starting equipment that has been damaged.

Whenever the pump is stored or idle in conditions that are near or below freezing, any water based fluids should be removed from the pump. The best way to do this is to run the pump for a few seconds with the suction and discharge lines disconnected or open to atmosphere. This will clear the majority of the fluid from the pumping chamber as well as the suction and discharge manifolds. After the run, blow compressed air through the fluid end to remove all traces of fluid. If possible, remove plugs from the bottom of the fluid cylinder and lift up the suction valve seats to ensure that all fluid is drained from the pumping chamber between the suction and discharge valves.

As an alternative to the previous procedure, a compatible antifreeze solution can be circulated through the fluid end. RV antifreeze, propylene glycol, is recommended for

this purpose. Remember that any fluid that poses an environmental hazard or is toxic must be handled and disposed of properly.

## 4.0 Installation Guidelines

A proper installation is essential to optimal performance, long service life, and reduced maintenance requirements. Take time to thoroughly plan all aspects of your installation.

### 4.1 General Location

It is important to position the pump on as flat and level a surface as possible to assist the splash oil lubrication system. Park mobile equipment, such as sewer cleaner trucks or drilling machines, on as level a surface as possible. Whenever possible the pump should be mounted in a clean, dry location with sufficient lighting and adequate space for easy inspection and maintenance. Locate the pump as close to the suction source as possible to allow for the shortest and most direct routing of the inlet piping.

### 4.2 Mounting Pump to Foundation and Power Source

The L06 through L16 model pumps described in this document must be mounted in a horizontal position only. Secure the pump to the mounting surface using the four (4) holes provided in the pump base. Check motor or engine rotation direction to ensure that the top of the industrial pump pinion shaft, on pumps with the pinion shaft gear reduction, rotates away from the pump fluid end when in operation. On HD or other pump models that do not have a pinion shaft, the top of the pump crank shaft should rotate toward the pump fluid end when in operation.

For units that are V-belt driven, check the alignment of the sheaves after the unit is installed on its permanent mounting. Tighten belts to the proper tension as recommended by the belt manufacturer. Verify that the sheaves are in line and parallel to each other with a straight edge.



**Never operate the pump without the belt or shaft guard securely installed.**

**CAUTION**

---

For direct-coupled or spline-driven units, ensure that the shafts are centered and parallel when the driver is mounted to the pump. Follow the coupling manufacturer instructions for installation procedures and tolerances.

### 4.3 Bearingless Hydraulic Motor Drives

L09 through L16 pumps may be ordered with a flanged adapter that allows a hydraulic motor to be direct coupled to the pump frame. To mount this motor, first attach the spline adapter or cross-over adapter to the crankshaft. This adapter can be splined, keyed, or threaded and should make a positive stop on the crank.

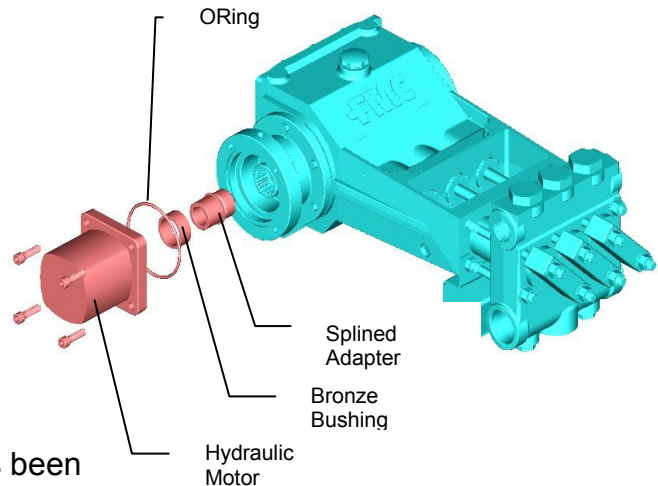

Check to ensure that the bronze bushing has been pressed into the proper bore of the motor.

Install the o-ring around the pilot diameter on the mounting face of the motor. Lubricate the o-ring with hydraulic fluid or o-ring lubricant to ease assembly in the mounting flange/bearing housing. Clean the inside of the mounting flange/bearing housing and motor face. Insert the hydraulic motor into the mounting flange/bearing housing. A slight twist may be needed to allow the motor spline to align with the internal spline of the adapter.

Torque the attaching bolts to the specified value. There should be no gap between the face of the motor and the mounting flange/bearing housing. Complete the motor installation by plumbing the hydraulic fittings and hose as instructed by the motor manufacturer.

### 4.4 Suction Piping Recommendations

Poor suction piping practices are a very common source of pump problems. To ensure proper operation it is very important to follow good design practice in the installation of the suction system before the pump is operated. A small amount of additional planning and investment in the piping system usually provides for better pump performance and longer periods between service requirements. It is difficult to diagnose many pump problems without the aid of a suction pressure gage. For this reason, FMC recommends that a gage always be installed in the suction line directly before it enters the pump.

The suction line from the fluid source to the pump should be as short and direct as possible. Use rigid piping, non-collapsible hose or a combination of both as circumstances require in your installation. The suction pipe size should be at least equal to or one size larger than the pump inlet. Long piping runs, low suction heads, or indirect pipe routing may require even greater over sizing of the suction line for proper operation of the pump. A suction pulsation dampener is recommended to reduce the effects of acceleration head to help when suction conditions are not optimal. In some cases it may be necessary to install a booster pump in the suction line of the pump to obtain sufficient pressure for the pump to operate successfully.

The suction line must be configured so there are no high spots in the line where air pockets can collect. These pockets may make the pump difficult to prime and cause rough, erratic operation. A drain valve or plug should be installed at the low point of the suction line to allow for draining before freezing conditions or for maintenance.

FMC recommends that all piping be supported independently of the pump. By supporting the piping this way, vibrations are reduced and stress on the pump is kept to a minimum. The use of elbows, nipples, unions, or other fittings should be minimized. Make sure that all joints and connections are airtight. Air leaks reduce the capacity of the pump and can result in cavitation, rough operation, and/or loss of prime. To help isolate mechanical and hydraulic vibrations, FMC recommends the use of flexible pipe couplings or hose connections between the pump and any rigid piping.

Always ensure that calculated system Net Positive Suction Head available, NPSHa, exceeds pump Net Positive Suction Head required, NPSHr, by at least 5 feet (1.5 meters) of water for proper operation of the pump. NPSH requirements for each pump model are provided on the product data sheets available through FMC or your authorized FMC reseller. FMC does not recommend using the pump in static lift conditions without prior factory approval.

#### 4.5 Discharge Piping Recommendations

1. Route the discharge piping in as short and direct a route as possible. Use the same pipe size as the outlet of the pump. In installations where the discharge piping is in excess of 50 feet (15 meters), FMC suggests using the next larger size pipe to minimize friction losses downstream.

Table 1: Pipe Pressure Chart

Allowable Working Pressure For Steel Pipe (PSI @ 100F)					
Pipe Size (inches)	Pipe Schedule Number				
	40	80	120	160	XX
1/2	2,300	4,100		7,300	12,300
3/4	2,000	3,500		8,500	10,000
1	2,100	3,500		5,700	9,500
1 1/4	1,800	3,000		4,400	7,900
1 1/2	1,700	2,800		4,500	7,200
2	1,500	2,500		4,600	6,300
2 1/2	1,900	2,800		4,200	6,900
3	1,600	2,600		4,100	6,100
3 1/2	1,500	2,400			5,600
4	1,400	2,300	3,350	4,000	5,300
5	1,300	2,090	2,950	3,850	4,780
6	1,210	2,070	2,850	3,760	4,660
8	1,100	1,870	2,840	3,700	3,560

14.5 psi = 1 Bar



**CAUTION**

**Always use pipe or hose that is designed for your particular pressure requirements. Inadequate pressure ratings can allow hose or pipe to fail, resulting in equipment damage and possibly personal injury. Normal hose pressure ratings are clearly marked on the outer surface of the hose. Working pressure ratings for steel pipe can be obtained from the manufacturer or from the chart shown in Table 1.**

2. **Always use a pressure gage in the pump discharge line.** A properly functioning gage mounted at the pump (and before any valves) is required to accurately determine the operating pressure of a pump and aids in troubleshooting.
3. Ensure that all piping is supported independently of the pump to reduce vibrations and stress on the pump. Pulsation dampeners on the discharge are recommended to reduce pressure pulsation and resulting vibration. The use of elbows, nipples, unions, or other fittings should be kept to a minimum. Avoid short radius 90° elbows; use two long radius 45° elbows instead. To help isolate mechanical and hydraulic vibrations, FMC recommends using flexible pipe couplings or hose connections between the pump and any rigid piping or the use of pulsation dampeners.
4. A properly adjusted pressure relief valve or rupture disc must be installed directly downstream of the pump to prevent damage or injuries resulting from over pressure or deadhead conditions. The relief valve discharge line must be as large as the pipe outlet of the relief valve. Never install valves in the relief valve discharge line or between the pump and relief valve. FMC recommends that the discharge be returned to the tank or drain, not back into the pump suction line.
5. It is recommended that a start-up bypass line and valve be installed to allow flow to bypass the relief valve. This allows the pump to start in an unloaded condition (no discharge pressure).

## 4.6 Multiple Pump Systems

Special consideration must be taken to avoid vibration, pulsation, or uneven flow distribution problems when operating multiple reciprocating pumps using common suction and discharge piping headers. It is recommended that the user contact FMC or experienced industry consultants for assistance with the design of the system and pump installation in these situations.



## 5.0 How to Start a Pump



**CAUTION**

**Always take special precautions when starting a pump for the first time or after any extended shutdown. Never assume someone else has properly prepared the pump and system for operation. Always check each component of the system prior to every start-up.**

The checklist that follows is intended to be a general guide for starting a pump in a typical installation. Every installation is different, and each will have different requirements to ensure safe and successful operation. **It is the responsibility of the operator to determine the correct start-up procedure for each installation.**

1. Ensure the drain plug(s) on the bottom of the pump crankcase have been installed and are tight. Ensure that the oil level sight glass, if equipped, has been properly installed.
2. Check the oil level to ensure that the pump is properly filled with non-detergent motor oil, gear lube, or synthetic oil as described in Table 2 and that the oil has not been contaminated with water or other contaminants. NOTE: FMC pumps are shipped with no oil in the power frame and must be filled to the proper level with the proper grade of oil prior to start-up.

**NOTICE:** The L16 model pump requires 80W-90 gear oil. For all other pumps (L06 through L12) use Table 2 provided in Section 6.0 for selecting the correct type of non-detergent motor oil or synthetic oil for your service.

- Pump model L06 & L06 HD requires 2 quarts (1.9 liters) of oil
  - Pump model L09 requires 3 1/4 quarts (3.1 liters) of oil
  - Pump model L09 HD requires 4 quarts (3.8 liters) of oil
  - Pump model L11 & L11 HD requires 6 1/4 quarts (5.9 liters) of oil
  - Pump model L12 & L12 HD requires 6 3/4 quarts (6.4 liters) of oil
  - Pump model L16 requires 10 quarts (9.5 liters) of gear oil
3. If accessible, check the piston rods to ensure that they are free from abrasive particles or debris.
  4. Ensure the pressure relief valve and all accessory equipment have been installed and properly adjusted. Verify all joints are pressure tight.
  5. Open the suction line valve to allow fluid to enter pump. Prime the fluid cylinder if necessary on the initial start up or after the system piping has been drained. The valve covers may have to be cracked open to assist with priming.





**Do not loosen the valve covers with volatile or hazardous fluids**

**CAUTION**

6. Check to ensure that power is locked out and tagged out. Turn the pump over by hand if possible to ensure free, unobstructed operation.
7. Apply 10 to 20 drops of glycerin, or mineral oil to the pistons, cylinders and piston rods to lubricate the packing and seals.
8. Make sure that all guards are in place and secure. Verify that all personnel are in safe positions and that system conditions are acceptable for operation.
9. The pump is now ready to start. NOTICE: Whenever possible, use a bypass in the discharge line to allow the pump to start in the unloaded condition (no discharge and pressure). Slowly close the bypass line to bring the pump into full load conditions. Shut down immediately if the flow becomes unsteady, pressure fluctuates, or if unusual sounds or vibrations are noted.
10. Take temperature readings of the power end and stuffing boxes. Do not exceed 170°F (77°C) for L06 through L12 power ends.

## **6.0 Lubrication of Power End**

### **6.1 Recommended Lubricants**

Few factors can influence the life of a pump more than the power end lubricant (oil). Careful selection of the right type of oil for each particular application will help ensure optimal performance from an FMC pump.

The intent of this section is to state the general lubrication requirements for FMC pumps. The L16 model pumps require 80W90 gear oil. For all other pump models (L06 through L12) refer to Table 2. Several products are listed by manufacturer name in the table below in order to aid the customer in locating suitable lubricants. The following listing is not exclusive, nor an endorsement of any particular product or manufacturer. Consult FMC for lubrication recommendations for applications that fall outside of the conditions listed in Table 2 below.

**NOTE**

Lubricant temperatures should not exceed 170° F (77° C) for continuous duty or 180° F (82° C) for intermittent duty applications on L06 through L12 pumps. Crankcase temperatures that exceed these limits will cause the mineral based lubricant to prematurely break down. The result will be poor lubrication and failure of power end components.

## 6.2 Oil Changes

- Oil changes must be carried out after first 100 hours of operation, and subsequently after every 4000 hours or at least every 6 months. These intervals may be modified depending on actual operating conditions.
- Oil should be changed when hot to prevent build up of sludge deposits.
- It is advisable to check oil level daily. If more than 10% of the total capacity has to be added, check for oil leaks.
- Do not mix oils of different types, even if produced by the same manufacturer.
- Never mix mineral and synthetic oils.
- To avoid the risk of scalding or burns, pay attention to oil and power end temperature during an oil change.
- Follow environmental guidelines when changing and disposing of lubricants.

BUCKHORN  
PUMPS, INC.

Table 2: L06-L12 Lubricant Recommendations

Type of Service	Ambient Temp	Motor Oil Lubricant				Synthetic Lubricant *		
		SAE Grade	ISO Viscosity (cSt@40 C)	SSU Viscosity	Manufacturer Brand Name	SAE Grade	ISO Viscosity (cSt@40 C)	Manufacturer Brand Name
General Service	0 F to 100 F (-18 C to 38 C)	30	100	550	Texaco® Meropa 100 Shell® Omala 100 Shell® Rotella T SAE 30 Exxon® XD-3 30 wt Mobil® Trans HD-30	5W-40  NA	90.0@40 15.0@100  99.1@40 13.9@100	Shell® Rotella T Synthetic SAE 5W-40  Mobil® SCH 627
High Ambient Temperature Service	100 F to 130 F (38 C to 54 C)	50	220	1165	Texaco® Meropa 68 Shell® Omala 220 Shell® Rotella T SAE 50 Exxon® HD-3 50 wt Mobil® Trans HD-50	5W-40  NA	90.0@40 15.0@100  217@40 29.9@100	Shell® Rotella T Synthetic SAE 5W-40  Mobil® SCH 630
Cold Ambient Temperature Service	0 F to -30 F (-18 C to -34 C)	20	68	350	Texaco® Meropa 68 Shell® Omala 68 Shell® Rotella T SAE 20 Exxon® HD-3 20 wt Mobil® Trans HD-20	5W-40  10W-30  NA	90.0@40 15.0@100  12.0@100 69.9@40 10.9@100	Shell® Rotella T Synthetic SAE 5W-40  BP® Vanellus E 8 ULTRA 5W-30  Mobil® SCH 626
Frequent Start-Stop Operation		40	150	775	Texaco Meropa® 150			
SPECIALTY ITEMS								
Internal Rust Inhibitor				Cortec® VCI 329				
External Rust Preventative				Texaco® Metal Protective Oil L				

\*Synthetic lubricants are suggested for high or low temperature service.



**L16 pumps require 80W-90 gear oil**

**NOTE**

## 7.0 Inspection and Preventative Maintenance Chart

Routine maintenance is an essential part of any successful pump installation. Properly maintained FMC pumps are designed to offer years of trouble-free service.

Regular maintenance and inspection will keep your pump operating at peak performance. FMC pumps have been carefully engineered to minimize maintenance requirements and simplify these tasks when they are required. Regular inspections allow operators to become familiar with normal pump operation so they can recognize the signals of potential problems and schedule maintenance. The maintenance chart in

Table 3 shown below should be used as a guideline only. Many applications will require adjustment of the intervals shown in this chart for severe or unusual operating conditions.

Table 3: Maintenance Chart

Interval	Component	Service	Remarks
Break In Period	Crankcase Oil	Change	Drain and refill with new oil after first 100 hours of operation. Ensure that the magnetic drain plugs are cleaned to remove debris.
	Inlet Strainer	Inspect	Clean if Required. The amount of material in the strainer will determine the interval of cleaning.
Daily	Complete Pump	Inspect	General inspection of pump and system to check for proper operation of equipment.
	Piston cup sets	Inspect	Check the cylinder liner area of the pump for signs of leakage. Replace piston cups if leakage becomes excessive.
	Pump System	Flush	Required for shutdown when pumping fluids that may harden or corrode the pump if left inside once stopped.
	Crankcase Oil	Inspect	Ensure that the oil is at proper level and has not been contaminated by pumpage or condensation.
6 Months/ 4,000 hours	Crankcase Oil	Change	Drain and refill with new oil. Clean magnetic drain plugs.
	Fluid Cylinder Bolts	Inspect	Check the fluid cylinder and cylinder cover bolts with a torque wrench to ensure they are within specification.
	Connecting Rod Bolts	Inspect	Check the connecting rod bolts with a torque wrench to ensure they are within specification. This should be done in conjunction with oil change.

BUCKHORN  
PUMPS, INC.

## 8.0 Estimated Life of Wearing Components

The information given here is an estimate of the average wear life of listed components in clean liquid service. It is not a guarantee of life for any given application, but is intended to facilitate maintenance schedules and stocking of spares. The maintenance of the power end lubrication system will influence the life of the power end components. The speed of operation and percent of maximum allowable load will influence the life of both power end and fluid end parts. The temperature, abrasiveness, and lubricity of the liquid affect the life of fluid end expendables.

POWER END COMPONENT	ESTIMATED LIFE (Hours)
End Bearings (Roller or Ball)	20,000
Wrist Pin Bushings	10,000
Power End Cover Gasket	10,000
Connecting Rod Bearings	8,000
Oil Seal on Crankshaft or Pinion	5,000
Oil Seal on Piston (Pony) Rod	2,500
FLUID END COMPONENT	ESTIMATED LIFE (Hours)
Fluid Cylinder	16,000
Piston Holder	10,000
Valve Assembly	8,000
Ceramic Liners	3,000
Piston Cups	1,500

**BUCKHORN  
PUMPS, INC.**

## 9.0 Component Parts List

A typical pump configuration is shown below for general reference purposes. This will aid in identifying components for service procedures outlined in the following sections. Each size L series pump may have a slightly different appearance. The Industrial Pump models have a pinion shaft for internal gear reduction. Some of the "HD" series and other models may be configured without the pinion shaft and may have a mount face for a hydraulic motor.

The "HV" series will use AR valves and occasionally ball valves with fluid cylinders sized for these valves. Therefore, actual pumps supplied by FMC may use different components or may be configured differently than illustrated.

To order service parts or see exact component configurations for your particular pump, refer to the cross-section parts drawing in the literature kit supplied with the pump. Contact your local FMC pump distributor or FMC if you do not have this information.

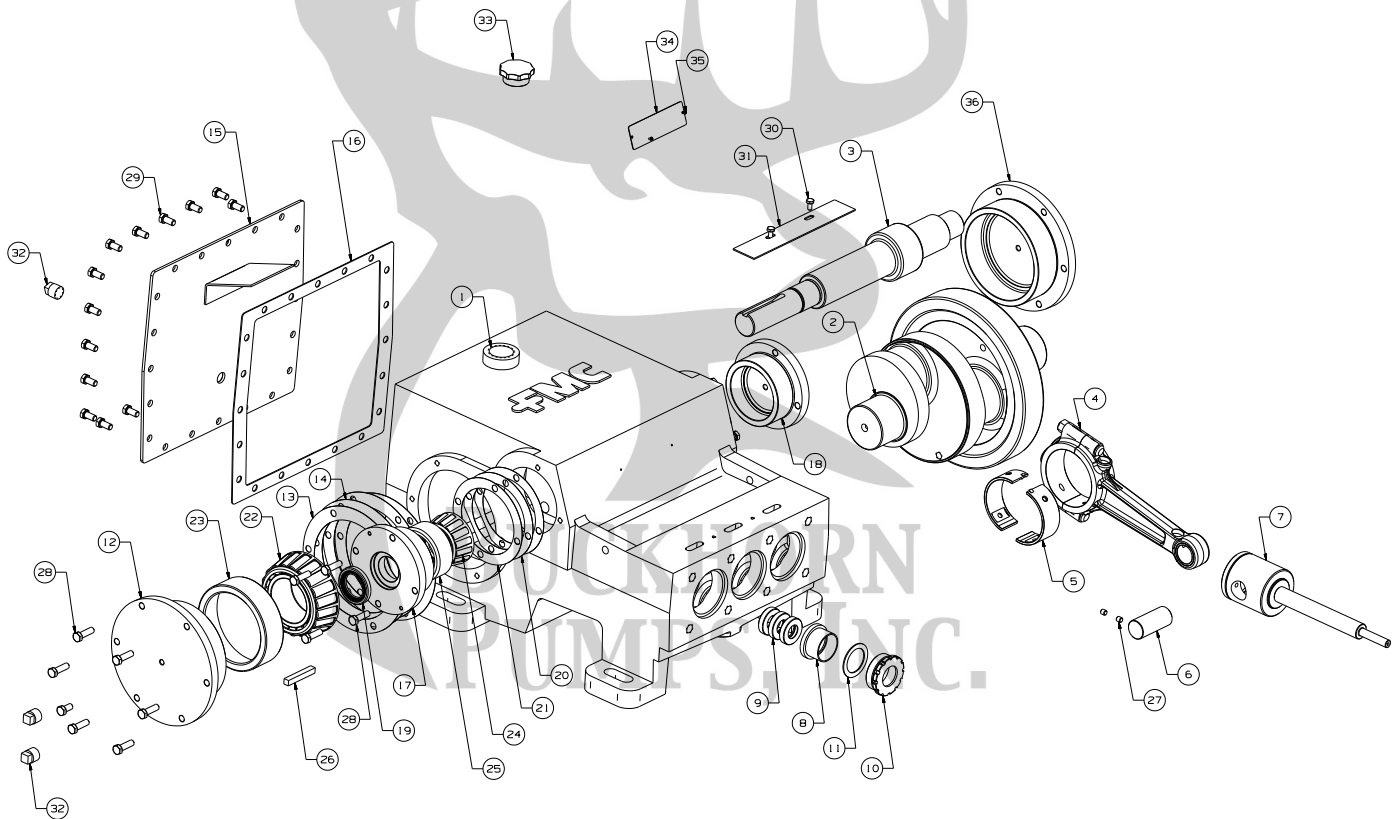

Figure 3: Power End Components



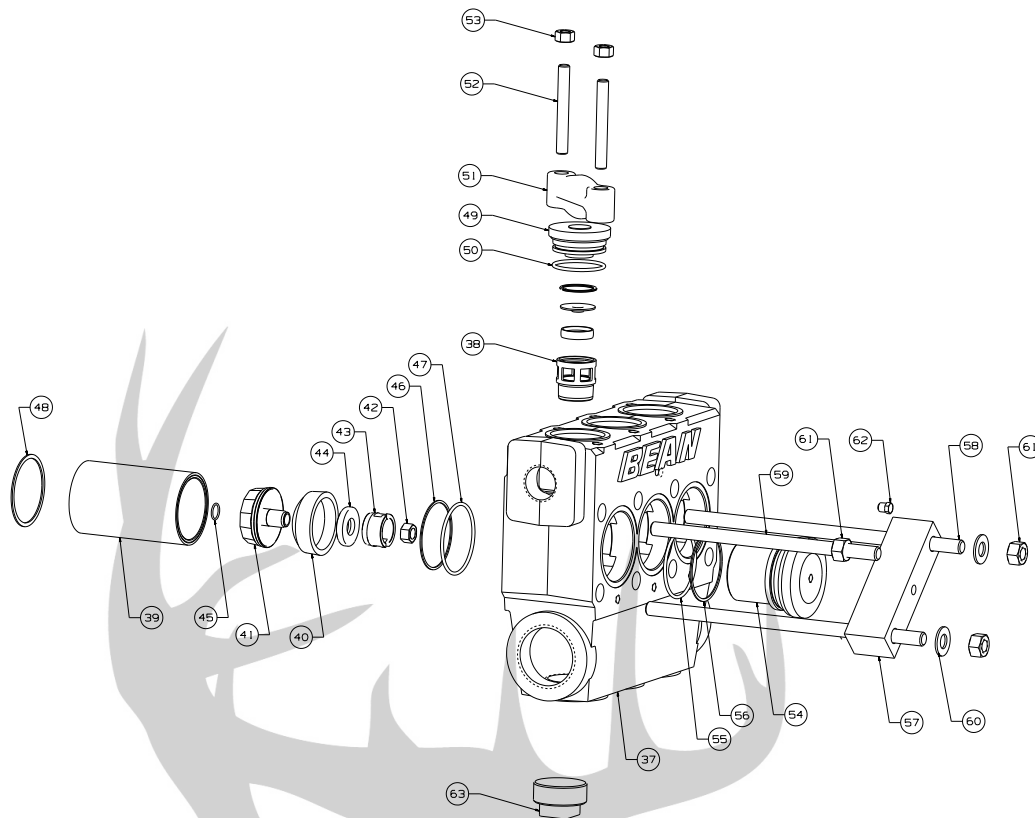

Figure 4: Fluid End Components

The illustrations above depict a typical pump with disc valves, and Type A piston cups. Alternate construction threaded style valve covers and Type B style pistons may be used on some models.

The service procedures outlined in this manual are intended to describe the more common pump configuration. Other configurations and minor design differences may exist with alternate pumps. Some procedures may require slight adaptations as a result.

BUCKHORN  
PUMPS, INC.

Table 4: Components List

Item No.	Component Description	Quantities for Each Model					
		L06 & HD	L09	L09 HD	L11 & HD	L12	L16
1	Power Frame	1	1	1	1	1	1
2	Crankshaft	1	1	1	1	1	1
3	Pinion Shaft	NA	1	NA	1	NA	1
4	Connecting Rod Assembly	3	3	3	3	3	3
5	Rod Bearing	6	6	6	6	6	6
6	Wrist Pin	3	3	3	3	3	3
7	Crosshead Assembly	3	3	3	3	3	3
8	Seal Holder	3	3	3	3	3	3
9	Oil Seal, Piston Rod	6	9	9	9	9	9
10	Seal Retainer Nut	NA	3	3	3	3	3
11	Gasket, Seal Retainer	NA	3	3	3	3	3
12	Bearing Housing, Blind	1	1	1	2	1	2
13	Shim, Bearing Housing	6	12	12	6	6	6
14	Gasket, Bearing Housing †	2	2	2	2	2	2
15	Back Cover	1	1	1	1	1	1
16	Gasket, Back Cover	1	1	1	1	1	1
17	Pinion Housing, Drive	NA	1	NA	1	NA	1
18	Pinion Housing, Blind	NA	1	NA	1	NA	1
19	Oil Seal, Rotating	1	1	1	1	1	1
20	Gasket, Pinion	NA	2	NA	2	NA	1
21	Shim, Pinion	NA	NA	NA	NA	NA	8
22	Bearing Cone, Crank	2	2	2	2	2	2
23	Bearing Cup, Crank	2	2	2	2	2	2
24	Bearing Cone, Pinion	NA	2	NA	2	NA	2
25	Bearing Cup, Pinion	NA	2	NA	2	NA	2
26	Key	1	1	1	1	1	1
27	Set Screw	3	6	6	6	6	6
28	Cap Screw, Bearing Housing	6	12	12	10	12	20
29	Cap Screw, Back Cover	12	14	16	20	16	23
30	Cap Screw, Plate	NA	2	NA	2	NA	2
31	Plate, Inspection	NA	1	NA	1	NA	1
32	Pipe Plug, Power End	2	2	2	2	2	5
33	Filler Cap or Vent	1	1	1	1	1	1
34	Nameplate	1	1	1	1	1	1
35	Tapping Screw	2	2	2	2	2	2
36	Bearing Housing, Drive	1	1	1	0	1	0
37	Fluid Chamber	1	1	1	1	1	1
38	Valve Assembly	6	6	6	6	6	6
39	Cylinder	3	3	3	3	3	3
40	Piston Cup	3	3	3	3	3	3
41	Piston Holder	3	3	3	3	3	3
42	Hex Nut	3	3	3	3	3	3
43	Plunger Nut	3	3	3	3	3	3
44	Piston Retainer	3	3	3	3	3	3
45	O-Ring, Rod Seal *	3	3	3	3	3	3
46	O-Ring, Fluid Cylinder	NA	NA	NA	3	3	3
47	Ring Seal	3	3	3	3	3	3

Subject to contractual terms and conditions to the contrary, this document and all the information contained herein are the confidential and exclusive property of FMC Technologies, and may not be reproduced, disclosed, or made public in any manner prior to express written authorization by FMCTI.

Item No.	Component Description	Quantities for Each Model					
		L06 & HD	L09	L09 HD	L11 & HD	L12	L16
48	Gasket, Power End	3	3	3	3	3	3
49	Valve Cover	3	3	3	3	3	3
50	O-Ring, Valve Cover	3	3	3	3	3	3
51	Clamp, Valve Cover	NA	NA	NA	3	3	3
52	Stud, Valve Cover	NA	NA	NA	6	6	6
53	Hex Nut, Valve Cover	NA	NA	NA	6	6	6
54	Cylinder Cover	3	3	3	3	3	3
55	O-Ring, Cylinder Cover	3	3	3	3	3	3
56	Back Up Ring	NA	NA	NA	3	3	3
57	Clamp, Cylinder Cover	3	3	3	3	3	3
58	Stud, Cylinder Cover	6	6	6	6	6	6
59	Stud, Fluid Cylinder	2	2	2	2	2	2
60	Flat Washer	8	8	8	8	8	6
61	Hex Nut	10	8	8	8	8	8
62	Pipe Plug, Drain	NA	NA	NA	4	4	4
63	Plug Suction	3	3	3	3	3	3

† Some bearing covers are sealed with gaskets and others use o-rings

\* Some piston holders are grooved for the o-ring, and others require a seal holder that is situated on the rod before the piston holder with the o-ring groove facing the piston holder.

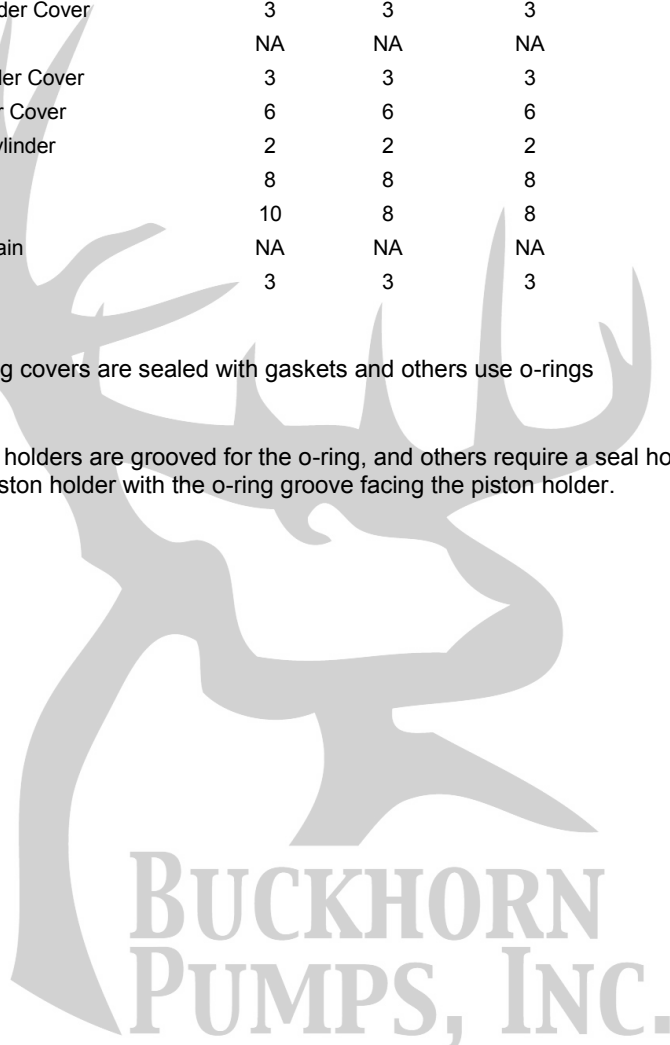

## 10.0 Service Procedures

FMC pumps are designed to simplify all required maintenance. The following sections illustrate step-by-step instructions for performing most common service procedures of a pump. Read each section before starting service work on the pump.

Refer to Figures 3 and 4 for location of components.



**Many accidents occur every year through careless use or service of mechanical equipment. You can avoid hazards associated with high-pressure equipment by always following the safety precautions listed in Section 1.0.**

### WARNING

## 10.1 Replacing Piston Cups

**Service Tip -** Due to the large uninstalled diameter, Type B piston cups on L0918 pumps (2.25" nominal bore diameter) cannot be inserted through the fluid end without the risk of damaging the sealing surface of the cup. Any pump with Type A cups are not affected, and you can skip directly to step 1 in this section.

**Service Tip -** To perform service on L0918 pumps equipped with Type B pistons, the fluid end must be removed and the liners taken to a bench or other suitable work area for assembly. Follow the steps outlined in section 10.2, "Removing the Fluid Cylinder", for information about this procedure.

**Service Tip -** Type B pistons in L0918 pumps must be installed in the piston liners using a press or vice as shown to the right. Be sure to protect both ends of the assembly with soft vice jaws, wood blocks, or a suitable non-marring material to ensure the components are not damaged during this process.

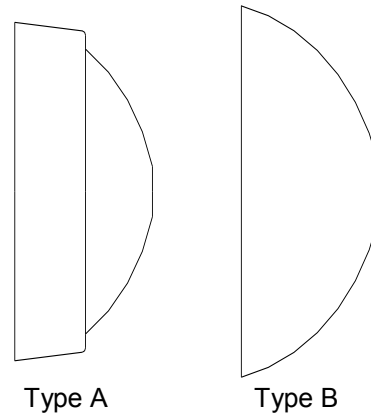

Type A

Type B



Service Tip – Press the piston assembly into the liner until the sealing lip has just entered the front of the liner. Use a small amount of glycerin on the ID of the liner to help lubricate the piston during installation. After the liner has been installed in the pump power frame, drive the piston assembly fully to its stop using the FMC piston tool (A5049) and a rubber mallet.

1. FMC recommends pumping a sufficient quantity of clean water through the fluid end before starting any service procedures that involve fluid end components. This will remove most contaminants left in the fluid cylinder by the normal pumpage and improve the ability to work with parts or see potential problems.

2. Bleed off all pressure inside the pump fluid end before starting any service work. Shut the valve on the inlet piping, if provided, to prevent flow of liquid from the source into the pump during service.

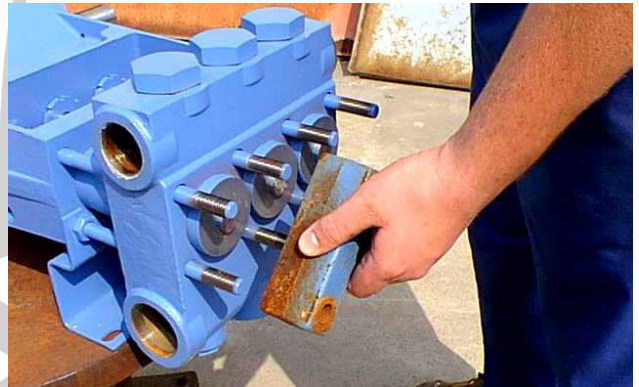

3. To service the piston cups (40), approximately 2 feet of clearance is required between the front of the pump fluid cylinder (37) and any obstructions. If there is insufficient clearance, the pump must be removed and relocated to an area where adequate clearance exists.

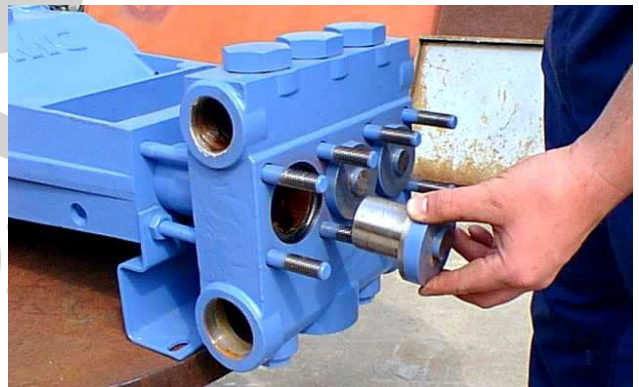

4. To access the piston cups (40), the cylinder cover clamps (57) must be removed. Remove six of the nuts (61) holding the cylinder cover clamps (57) in place, and then remove the cylinder covers (54). Do not remove the two nuts (61) on the opposite corners of the fluid cylinder, (except as noted for L0918 in service tips above and some L06 models), as they keep the cylinders (39) and fluid cylinder mounted on the pump during this operation.



- Some pumps may be equipped with a single cover plate that secures all three cylinder covers. For these models, all eight nuts (61) must be removed to facilitate removal of the cylinder covers (54). For some L06 models with no cylinder covers, the fluid cylinder (37) must be removed to access the pistons.

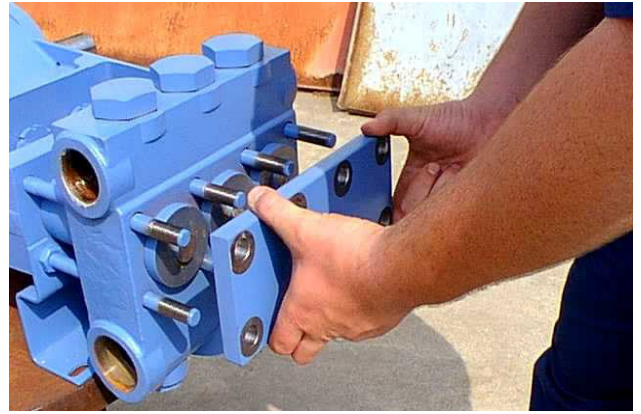

- Using a socket wrench with a long extension, remove the hex piston nut (42) from the piston/crosshead rod (7). This nut secures the piston assembly to the piston/crosshead rod.



- Following the hex piston nut (42) removal, use the FMC piston tool (A5049) to pull the piston assembly from the cylinder (39). Insert the FMC piston tool inside the cylinder until flush with the face of the slotted piston retainer nut (43). Twist the tool to engage and lock the tabs of the tool inside the mating slots in the retainer nut.



- Pull the piston assembly free of the pump using a combination pulling and twisting motion.

- Place the flats on the bottom of the piston holder (41) in a vice or clamp securely. Using the FMC piston tool, unscrew the piston retainer nut (43) and remove. The piston cup (40) and piston retainer (44) may now be removed.





10. Inspect all parts for damage or unusual wear. Ensure that the interior surface of the cylinder (39) is smooth and free of cracks or grooves. New piston cups (40) will fail prematurely if installed in liners with damaged bores. FMC recommends that all three piston cups are replaced, not just those that show signs of leakage whenever this type of service is performed. This will maximize operational time between service intervals.



11. Reverse steps 3 through 10 to rebuild the pump after worn or damaged components have been replaced. FMC recommends that all seals and gaskets that are disturbed during the service procedures be replaced. This includes the rod seal o-ring (45) that is located on the piston/crosshead rod (shown) directly behind the piston assembly. Some pump models have the o-ring in a groove in the piston holder instead of a separate seal holder. Lubricate the piston cups and piston rods during assembly.
12. Tighten all fasteners using the values and patterns specified in Fastener Torque Requirements, Section 11.0 of this manual.

BUCKHORN  
PUMPS, INC.

## 10.2 Removing the Fluid Cylinder



The fluid cylinder (37) may be removed to inspect for internal damage, to be repaired, to replace the fluid cylinder, to replace damaged cylinders, cylinder o-rings, or to service piston rod seals.

### NOTE

Some L06 pumps require fluid cylinder removal to service the pistons.

Refer to Figure 4 for illustration of parts.

1. FMC recommends that a sufficient quantity of clean water is pumped through the fluid end before starting any service procedures that involve fluid end components. This action will remove a significant portion of contaminants left in the fluid cylinder by the normal pumpage and improve the ability to work with parts or see potential problems.
2. Bleed off all pressure inside pump fluid end before starting any service work. Shut the valve on the inlet piping if provided to prevent flow of liquid from the source into the pump during service.



**ENSURE THE POWER IS LOCKED OUT AND TAGGED OUT**

### CAUTION

3. Remove the cylinder cover clamps (57) and cylinder covers (54) as described in the previous section. Remove the outside corner fluid cylinder nuts (61) if they are still in place.

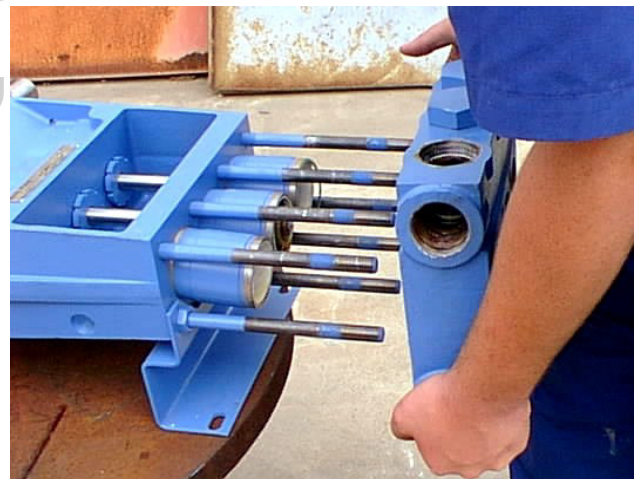

4. Rock the fluid cylinder (fluid chamber) (37) to loosen from the cylinders (liners) (39), and then pull free of the fluid end studs. If the pistons have already been removed, take care to ensure that the cylinders (liners) do not fall off of the front of the power end and become damaged.

5. To remove the piston assemblies, refer to the previous section.
6. Inspect all parts for signs of wear or damage. Replace parts if required.



7. Always replace the cylinder gaskets (48) when the cylinders have been moved or replaced.
8. Installation will be the reverse of this procedure.

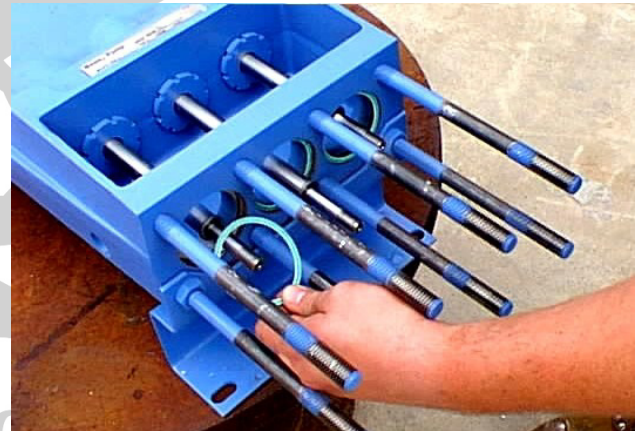

9. Tighten all fasteners using the values and patterns specified in Fastener Torque Requirements, Section 11.0 of this manual. Please note that if the nuts (61) on the fluid cylinder studs (59) are not properly torqued, a failure is likely.



### 10.3 Replacing Valves

1. Three types of valves may be supplied with various models of the L series pumps. They are disc type valves, AR style valves, and ball type valves. The next steps must be performed for each type of valve.
2. A minimum of approximately 2 feet of clearance is required above, below, and in front of the pump fluid cylinder to allow valve service without removal of the fluid end. If sufficient clearance is not available, the fluid end must be removed as outlined in previous section and taken to a work shop for valve service. The following procedure is written under the assumption that sufficient clearances exist.

3. Remove the three suction plugs (63) from the bottom of the fluid cylinder (37).
4. Remove the three valve covers (49), the threaded version is shown, or remove the six valve cover nuts (53) holding the valve cover clamps (51) and then remove the three valve covers (49) from the fluid cylinder. NOTE: Pumps that have threaded valve covers do not require removal of nuts and clamps.

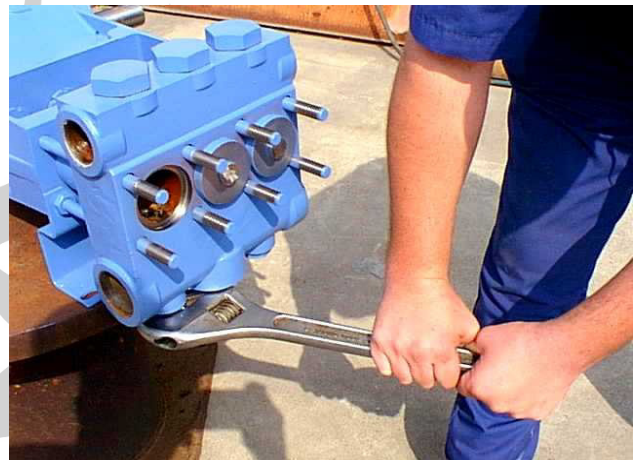

5. The cylinder covers (54) on most L series pumps allow access for inlet valve removal. For these pumps, remove the cylinder covers as described in section 10.2, steps 1 through 4. Some pumps may be equipped with a single cover plate. Refer to 10.2, step 5.



6. For AR valves refer to Section 10.3.1. This section describes the methods for removing and installing the AR valves.

7. For disc valves refer to Section 10.3.2. This section describes the methods for removing and installing disc valves.
8. For ball valves, also refer to Section 10.3.2. However, the balls are not retained in the valve seat. The ball can easily be removed from the valve assembly by lifting it out of the open cage portion of the valve seat. Then proceed with the appropriate Knock Out Tool to remove the valve seat from the fluid chamber.
9. After the valves have been replaced, inspect each o-ring (50) on each valve cover (49). FMC recommends that the valve cover o-rings be replaced if nicked or extruded. Install the valve cover with the o-ring in place (lubricate the o-ring), and install the valve cover clamps (51) over the valve cover studs (52). Replace valve cover washers (if installed) and the valve cover hex nuts (53).
10. Torque the valve cover hex nuts or hex plugs using the values and pattern specified in Fastener Torque Requirements, Section 11.0 of this manual.

Installation Tip: Add grease around each o-ring on the valve covers to prevent o-ring from falling out of cover when turned over for installation.



BUCKHORN  
PUMPS, INC.

### 10.3.1 Replacing AR Valves

#### 10.3.1.1 Introduction

The AR, Abrasion Resistant, valve is a durable wing-guided, spring-loaded check valve. It is used with abrasive fluids, bentonite mud, water, oil etc., and provides excellent performance and long service life. A typical valve is shown in Figure 5 with valve components identified in the exploded view to the right.

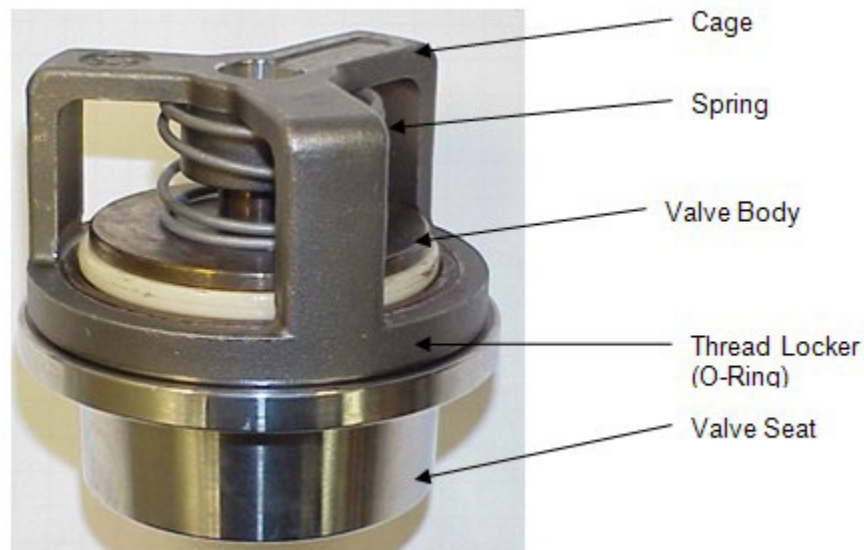

Figure 5: AR Valve Assembly

The primary difficulty in removing an AR Valve is associated with the removal of the tapered seat from the matching locking taper in the fluid cylinder. If the pump is used for discharge pressures in excess of 3,000 psi or for corrosive fluids, this can be a difficult task which requires special tooling.

FMC provides four types of tools that can be used to remove AR type valves. Some of the tools are specific to the pump model, some are used only with specific valves, and others can be used with any AR installation. Refer to Section 13.0, Valve Removal and Installation Tools, Table 8 for the appropriate tool recommendations.



### 10.3.1.2 Knock Out Tool

The Knock Out tool, part number [P504436](#) is used primarily on the M06 and L06 model pumps for small valves.

To remove a valve, this tool is inserted from the bottom of the fluid cylinder and is stopped by the bottom of the valve seat. Take care not to contact the tool to the valve body as striking this component can damage the valve cage and ruin the valve. The tool is struck sharply with a rubber mallet and the valve is loosened. The suction valve can be removed first through the cylinder cover (if the fluid cylinder is equipped with them) and the discharge valve through the valve cover. If the fluid cylinder does not have cylinder covers the fluid end must be removed first to allow access (See Section 10.2 for fluid cylinder removal instructions).

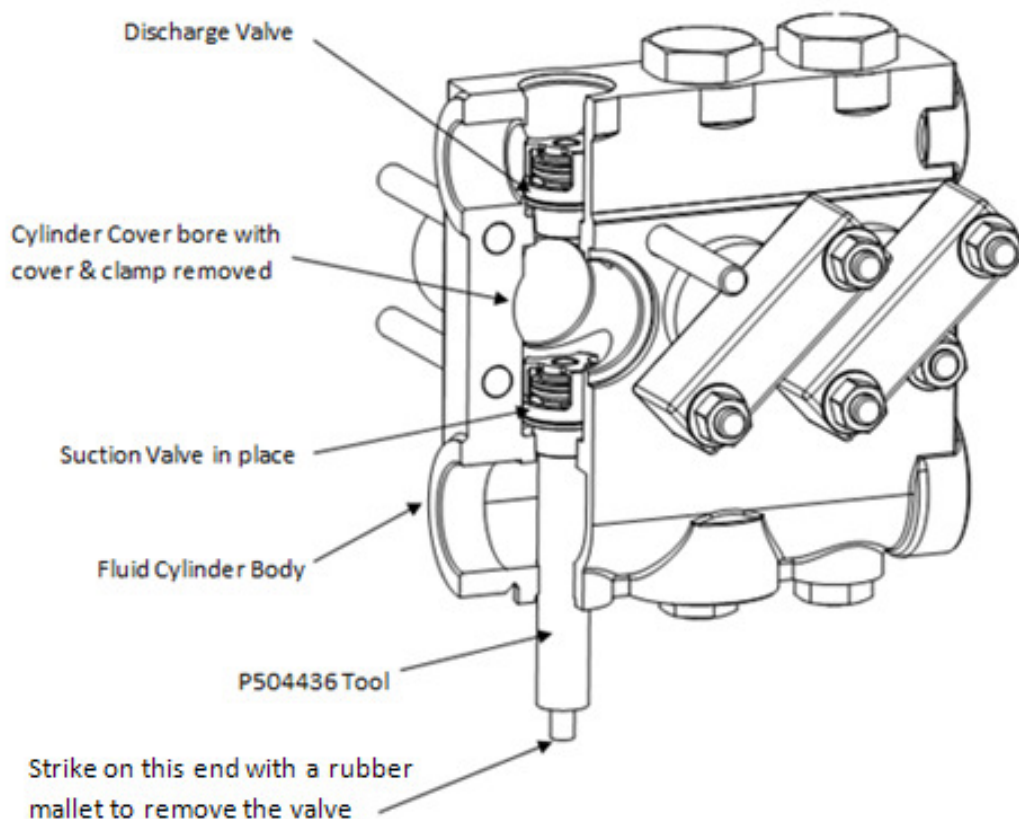

Figure 6: Using the Knock Out Tool

Figure 7 and Figure 8 on the following page show the tool in use.



Figure 7: Removing the valve from the seat



Figure 8: Removing the valve from the fluid cylinder

### 10.3.1.3 Valve Cage Removal For Eccentric Disc Method

The eccentric disc method for removing AR valves is more complex but capable of exerting more force on the valve than the Knock Out Tool. This method can be used on all sizes of the AR valves in all of the pump models. The discharge valve is removed first. The valve must be disassembled with the cage, spring and valve body removed from the fluid cylinder prior to the seat being pulled. A special hex drive tool will assist in removing the cage from the seat. Take care not to gall the threads on the valve cage or the seat.

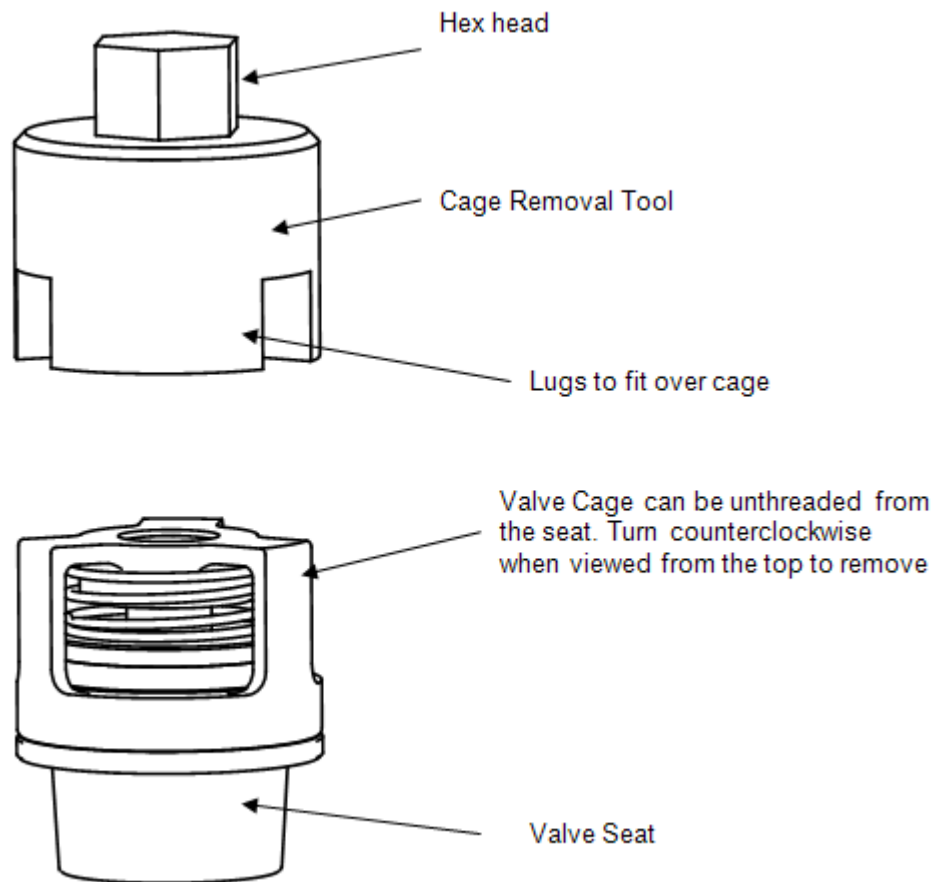

Figure 9: Valve Disassembly

### 10.3.1.4 Eccentric Disc

This method requires a tool that includes a disc that passes through the seat to allow force to be placed underneath it. The disc has a threaded hole that is at the center of the disc (concentric disc). A tension rod is threaded into the hole. The second disc has an eccentric hole with clearance for the tension rod and sits on top of the threaded disc. This keeps the threaded disc engaged with the edge of the seat.

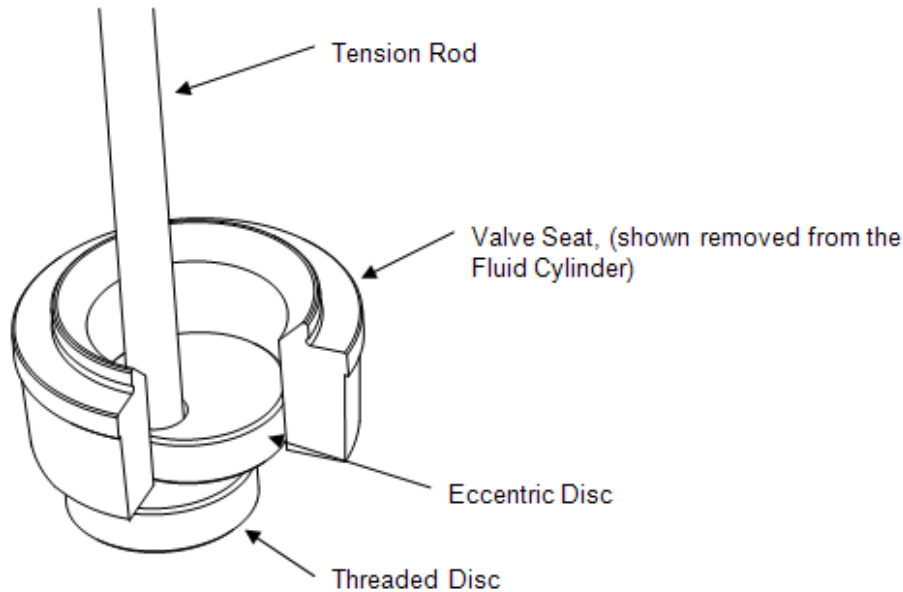

Figure 10: Eccentric Disc in Use

The tension rod is located through the top of the fluid cylinder and through a strong back that rests on the top of the fluid cylinder. A nut is threaded over the tension rod and tightens down on the strong back. The nut is tightened to place the rod in tension, putting upward pressure on the valve seat.

A bumper is placed over the tension rod with a nut stop above the bumper. After the nut on the strong back is tightened (tensioning the rod), rapidly move the bumper upward to strike the retaining nut. This imparts a shock load into the seat. This sequence is repeated until the seat pops loose from the fluid cylinder.



**CAUTION**

The seat may pop suddenly when force is applied. Stand with feet apart when applying striking action. Keep head back so the tool does not strike your jaw when the seat pops. Ask for a work partner to steady you to avoid slipping. The bumper sliding upward against the stop nut creates a pinch point that can cause hand injury if gripped improperly. Always hold the bumper by the handles only and use leather work gloves to lessen the shock to your hands.

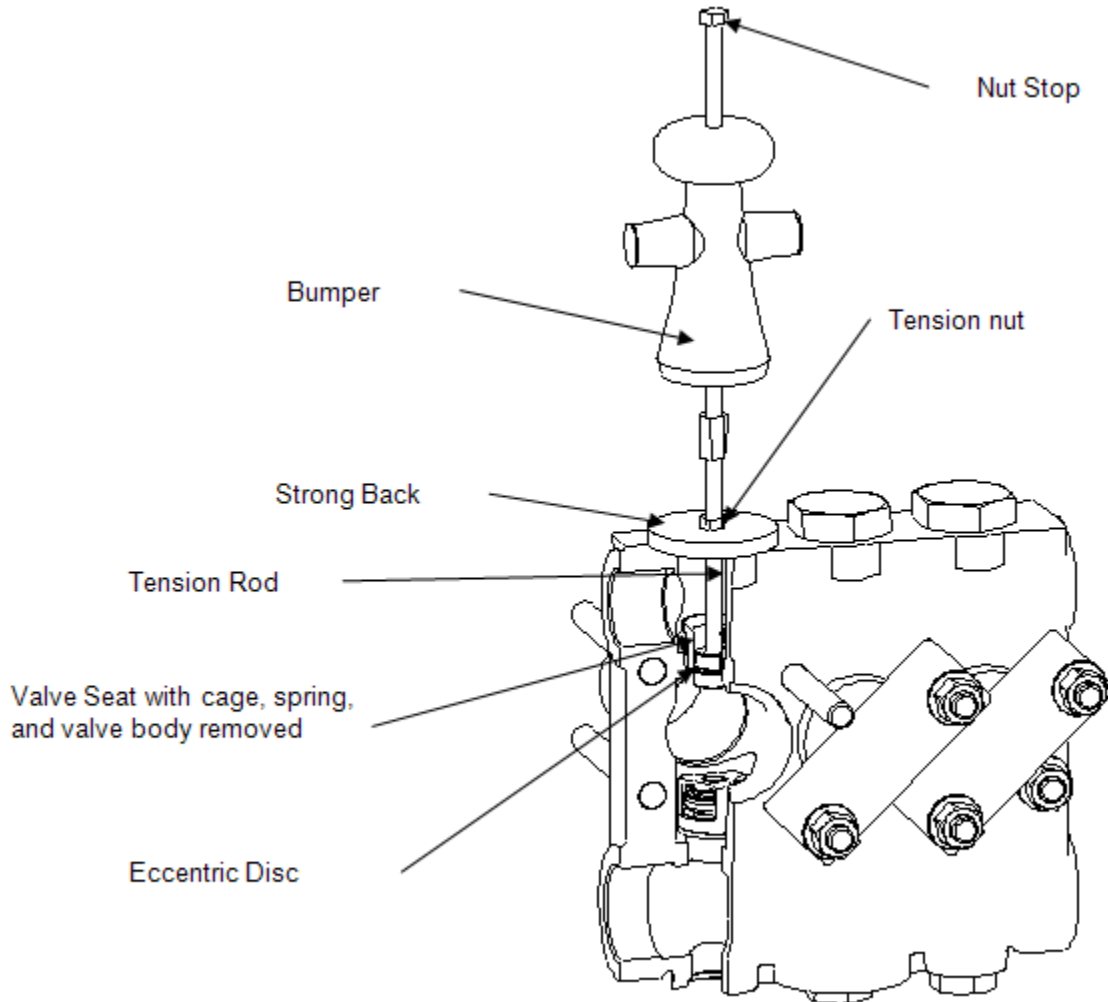

Figure 11: Removing the seat

A variation of this method is the use of a hydraulic pump and cylinder jack (porta power) to generate the load that the bumper, strong back, and nut would generate. This is shown in Figure 12. DO NOT place the strong back on top of the valve cover studs, the strong back must be placed on the machined surface on top of the fluid cylinder. It is useful to put dry ice on the seat if it will not loosen. Allow five minutes for cooling of seat before attempting removal.





Dry ice will cause freeze burns to skin if contacted. Use thick leather gloves when handling. Dry ice is often available at grocery stores.

**CAUTION**

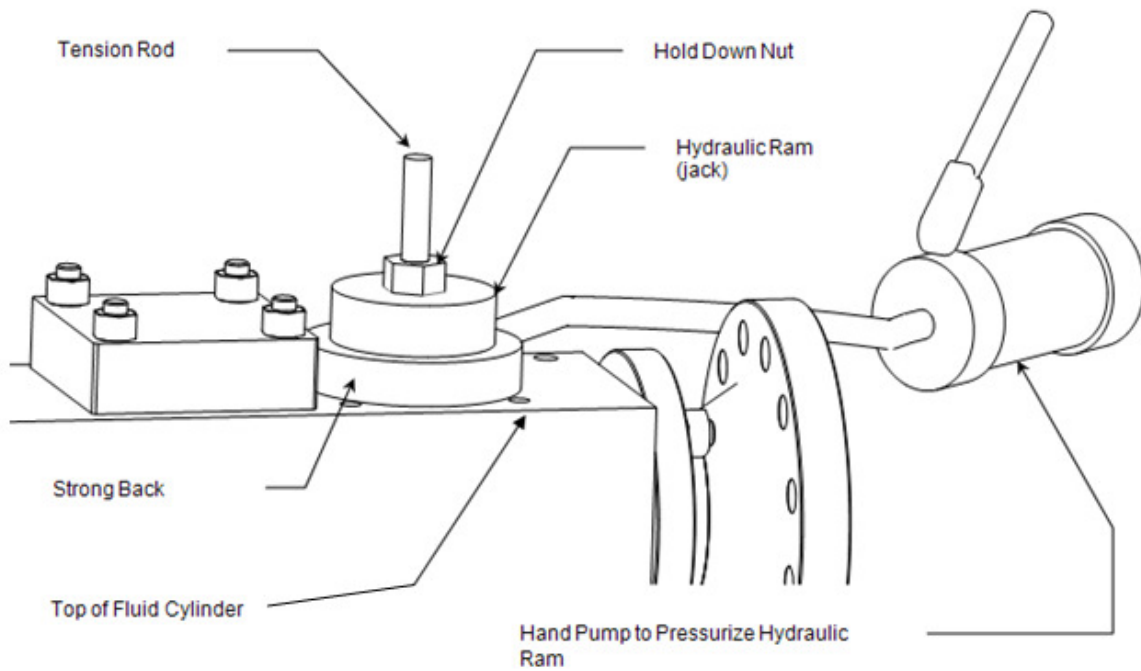

Figure 12: Hydraulic Power used to Remove Valve Seat

**10.3.1.5 Threaded Type (AR Valves Only)**

The threaded ID puller method can only be used on valves that have the through bore of the seat threaded prior to installation. This is the last variation of methods of applying tension to the valve seat to remove it from the fluid cylinder.

Again the valve must be disassembled with the cage, spring, and valve body removed leaving only the seat in the fluid cylinder prior to use of the puller. Take care not to gall the threads on the valve cage or the seat.

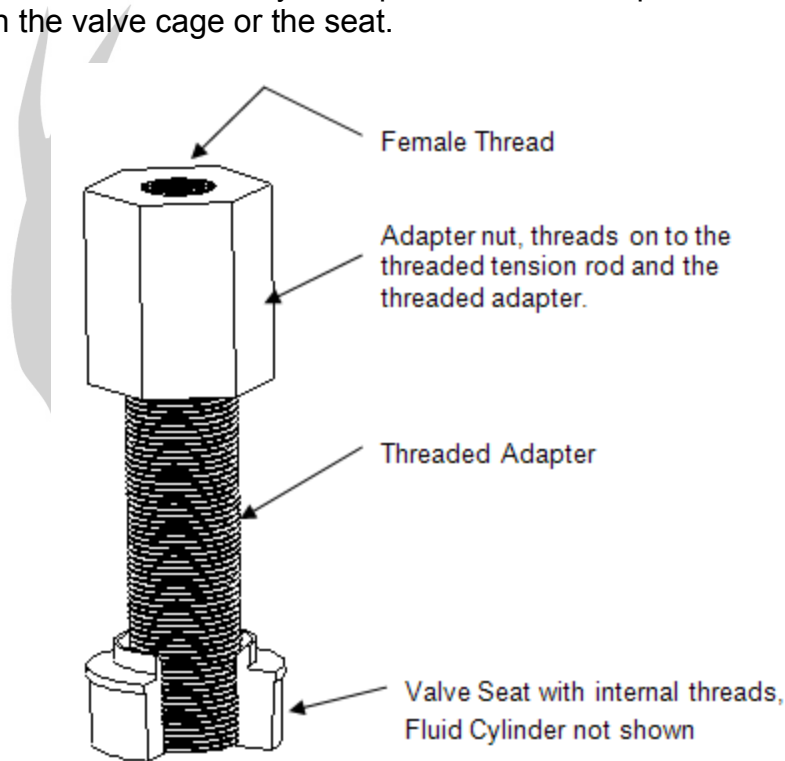

Figure 13: Threaded Tool in Use

A threaded adapter is screwed into the seat after the cage, spring, and valve body have been removed. An adapter nut mates the threaded section to the tension rod. Using the strong back and other parts used on the Eccentric disc method a force can be applied to remove the seat from the fluid cylinder.

The threaded seat is used on high pressure applications (above 5000 PSI) where the required removal force for the seat is high. With high removal forces required, the hydraulic puller is recommended over the nut, bumper, strong back, and puller assembly.

### 10.3.1.6 Installation of AR Valves

AR valves are installed differently depending on their size. Larger valves are assembled at the factory with the cage screwed on hand-tight before shipping while smaller valves are tightened with a torque wrench to final specifications. Follow the instructions in Section 10.3.1.6.1 for all Series 3 and 23 valves as well as valve part numbers [3267652](#) and [P533637](#). See Section 10.3.1.6.2 for all larger AR valves.

#### 10.3.1.6.1 Installing Smaller, Factory Torqued AR Valves

The suction valve must be installed before the discharge valves. The following reassembly procedure is applicable for both.

1. Select a new valve assembly.
2. Carefully clean the taper in the fluid cylinder and on the valve seat with a cleaning solution and a clean cloth. Small scratches can be removed with steel wool or 100 grit emery paper. Remove all dirt, grease, oil, water, or other contaminants from the surfaces. Do not oil the seats or the seating surfaces in the fluid cylinder. Confirm that they are dry before installation.
3. Position the valve assembly directly over the mating taper in the fluid cylinder.
4. Let the valve drop into the taper. Check to see that the seat is sitting in the taper properly and not cocked to one side. If the valve drops straight, it will seize on the taper. When correctly seated, it cannot be pulled up by hand.
5. Place the small end of the knockout tool, part number [P504436](#) (see Section 10.3.1.2), through the hole in the cage onto the center of the valve body.
6. While applying downward pressure on the tool, strike the end two times with a hammer to seat the valve. Be very careful not to strike the cage as this will cause the valve to be damaged and fail.
7. Verify that the valve body moves freely.

8. After the valve is secured in the fluid cylinder, verify the cage is torqued to 30 ft-lbs (40.7 N-m).

#### 10.3.1.6.2 Installing Larger, Non-Factory Torqued AR Valves

The suction valve must be installed before the discharge valves. The following reassembly procedure is applicable for both.

1. Select a new valve seat. Disassembly of a new valve assembly may be necessary. Do not install complete assembled valves.
2. Carefully clean the taper in the fluid cylinder and on the valve seat with a cleaning solution and a clean cloth. Small scratches can be removed with steel wool or 100 grit emery paper. Remove all dirt, grease, oil, water, or any other contaminants from the surfaces. Do not oil the seats or the seating surfaces in the fluid cylinder. Confirm that they are dry before installation.
3. Position the valve seat directly over the mating taper in the fluid cylinder.
4. Let the seat drop into the taper. Check to see that the seat is sitting in the taper properly and not cocked to one side. If the valve drops straight, it will seize on the taper. When correctly seated, it cannot be pulled up by hand.
5. Place a flat clean piece of brass or plastic on the face of the seat. If available, an old valve disc will work well. With a metal rod or punch, strike the end of the tool two times with a hammer to seat the valve.
6. After the seat is secured in the fluid cylinder, the valve must be assembled. Apply anti-seize solution to the cage threads before threading onto the seat. Care must be taken when threading the cage onto the seat. This is a very fine thread and can easily be damaged by cross-threading. Tighten the cage against the o-ring which acts as a thread locking device. Torque the cage to 30 ft-lbs.



Use the hex cage removal tool for reassembly. The tool is shown in Figure 9

**NOTE**

### 10.3.2 Replacing L Series Disc Type Valves

#### 10.3.2.1 Introduction

The disc type valve used in L series FMC pump models is shown in Figure 14. The standard construction of stainless steel seat, disc, and stop are a cost effective design with excellent performance and ample life. These valve assemblies come pre-assembled from the factory and should not need to be disassembled.

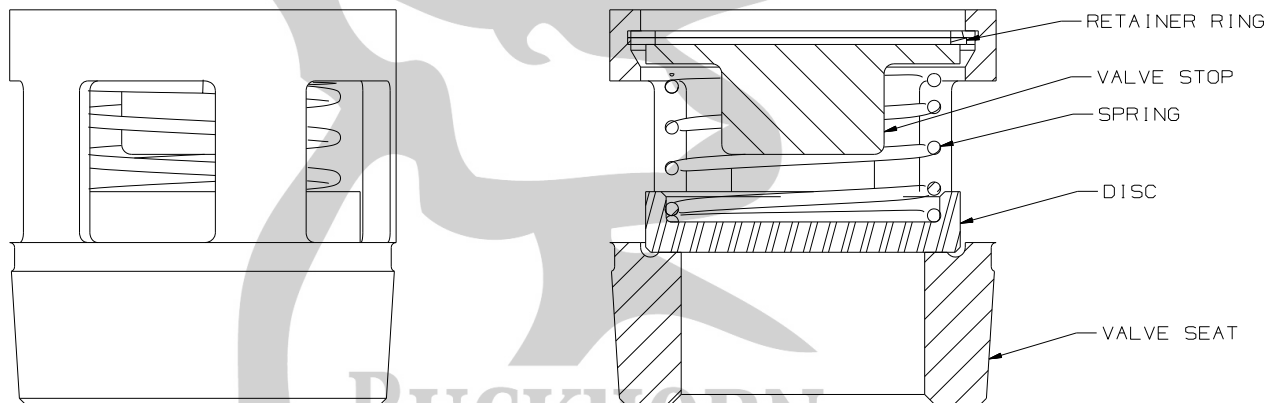

Figure 14: Typical L Series Disc Valve Assembly

When a worn or malfunctioning valve is detected, it must be replaced. With disc valves the most difficult task associated with replacing a valve is the removal of the seat from the fluid cylinder. The seats are held into the fluid cylinder with a matching locking taper. Removal is particularly difficult if the discharge pressure of the pump was over 3,000 psi or corrosive fluid was pumped.



### 10.3.2.2 Valve Removal Tools

There are three Knock Out tools available for removing valves from L series pumps. The [P534695](#) Small Ball Knock Out tool is the preferred tool for the smaller valves in the L06 and L09 pumps. The [P504436](#) Knock Out tool can also be used on the smaller valves in the L06 and L09 pumps. The [P534694](#) Large Ball Knock Out tool is designed for the larger valves in the L11 through L16 pumps. The valves and appropriate tools are listed in Table 9.

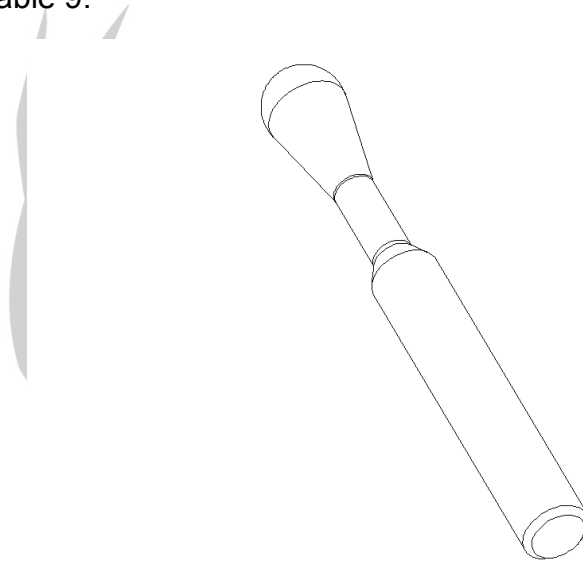

Figure 15: Illustration of the [P534694](#) and [P534695](#) Ball Knock Out Tools

The suction valve is removed first.

All Knock Out tools are used in a similar manner to the [P504436](#) tool shown in Section 10.3.1.2. The [P534694](#) or [P534695](#) ball type tools are used with the ball end positioned against the bottom of the valve seat.

### 10.3.2.3 Installation of Disc Valves

The suction valves must be installed before the discharge valves can be installed. The following reassembly procedure is applicable for both.

1. Select a new valve assembly and check to ensure the taper on the valve is clean.

2. Carefully clean the taper in the fluid cylinder and on the valve seat with a cleaning solution and a clean cloth. Small scratches can be removed with steel wool or 100 grit emery paper. Remove all dirt, grease, oil, water, or any other contaminants from the surfaces. Do not oil the seats or the seating surfaces in the fluid cylinder. Confirm that they are dry before installation.
3. Position the valve assembly directly over the mating taper in the fluid cylinder.
4. Let the valve seat drop into the taper. Check to see that the seat is sitting in the taper properly and not cocked to one side. If the seat drops straight, it will seize on the taper. When correctly seated, it cannot be pulled up by hand.
5. Place the appropriate installation tool on the top surface of the valve assembly. The suction valve will require tool [P534696](#) for the small valves and tool [P534699](#) for the larger valves. Using the Ball Knock Out tool, strike with a hammer three times to seat the valve.
6. Repeat steps 1 through 5 for the discharge valve.
7. Place tool [P534696](#) for the small valves on the top surface of the valve and use the Ball Knock Out tool as described in step 5 to seat the valve. For the larger valve use tool [P534702](#) that has the handle included. Strike the end of the handle three with a hammer to seat the valve.



BUCKHORN  
PUMPS, INC.

## 10.4 Servicing the Power End

### 10.4.1 Replacing Piston Rod Oil Seals



Ensure that all pressure inside the pump fluid cylinder has been bled off before starting any service work.

**NOTE**



**ENSURE THAT THE POWER IS LOCKED OUT AND TAGGED OUT.**

**CAUTION**

1. The piston rod oil seals (9) retain oil in the power end and prevent contamination from entering the power end by way of the piston rods. The fluid end and cylinders must be removed as outlined in the previous sections to provide access to these seals.



2. For L09 through L16 models, rotate the seal retainer (10) counter clockwise until it is unscrewed from the frame, then slide off of the rod. Use a screwdriver and mallet to rotate the seal retainer. For L06 models, the seal holder (8) is press fit into the power frame and the seals (9) are press fit into the seal holder. This can be done using a 1 ¼ NPT coupling with an appropriate length of pipe attached installed onto the seal holder. Move in an oscillating motion to work the seal holder out.

3. For L09 through L16 models, pull the seal holder (8) out of the pump frame and slide off of the rod. It may be necessary to insert a screwdriver or pointed tool into one of the holes in the seal holder on the L09 to help extract it from the power frame. For L11 through L16, it will require using two screwdrivers to slide the seal holder out of the recess. A slight rocking motion on the seal holder may aid in removal.

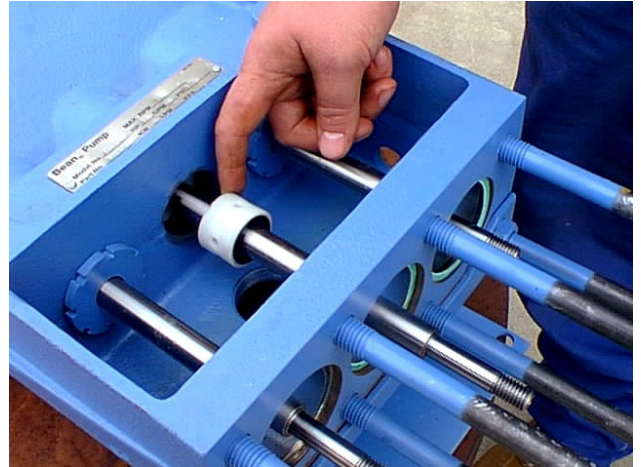

4. Remove the seal retainer gasket (11) from the power frame. Inspect the seals (9) and note the orientation of the seals prior to removal. The seals may now be removed from the seal holder and discarded.
5. To rebuild, insert new seals (9) in the seal holder (8), taking care to ensure they are oriented in the same manner as the ones that were removed. Do not reuse seals that have been removed from the pump. Replace the seal retainer gasket (11).
6. Wrap tape or other material over the exposed piston rod threads to protect the new seal lips from damage. Install the seal retainer gasket then slide the seal holder over the protected threads and into the pump frame. Care must be taken to ensure the seal lips are not folded or cut when passing over the ends of the rod.
7. On L09 through L16 ensure that the gasket (11) and seal holder (8) are in place, install the seal retainer (10) and tighten until it bottoms out. Take care when starting threads of retainer as they are easy to cross thread. Do not over tighten as it can damage the seal retainer gasket. For L06 pumps, apply silicone gasket compound to the rear face of the seal holder, slide over the rod as described above, and press fit into the power frame (1) bore.
8. Remove the protective material that is covering the rod threads. Rebuild the remainder of the pump as outlined in previous sections. Tighten all fasteners using the values and patterns specified in Fastener Torque Requirements, Section 11.0 of this manual.

## 10.4.2 Replacing Power End Bearings & Crankshaft



Disconnect the driver from the pump and ensure that suction and discharge lines are disconnected or blocked and have no pressure applied.

### CAUTION

1. Removal of the fluid cylinder is not required but can simplify crankshaft removal. However, on L16 pump models removal may be required.
2. Remove magnetic pipe plug (32) to allow all oil to drain from power frame (1).
3. Remove all rear cover cap screws (29). Remove the back cover (15) and back cover gasket (16) from the power frame.

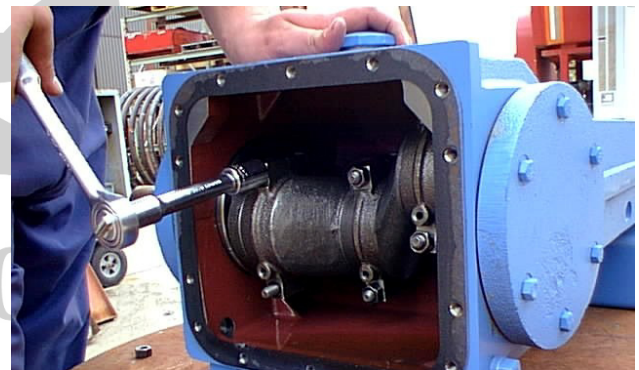
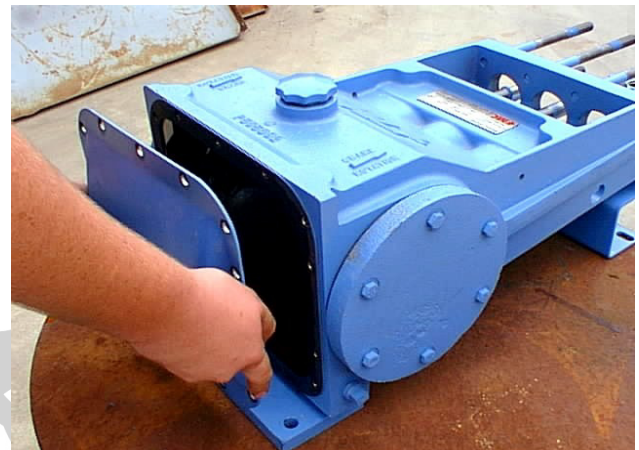

BUCKHO  
PUMPS, INC.



4. Remove the end cap of each connecting rod (4) by unscrewing the two hex nuts that hold each cap to the connecting rod body. The cap can be removed from the body by tapping with a rubber mallet on the cap screws to remove them and then tapping on the end cap to loosen it. Take care to not damage the threads on the cap screws.



5. Slide the two rod bearing halves (5) from each connecting rod (4). Note that these parts sometimes adhere to the pins (journals) on the crankshaft (2).

6. NOTE: Connecting rods and caps are matched sets and must always be reassembled with their original mate and in the same orientation. Note the numbered codes stamped on each half of the connecting rod assemblies and make certain they are installed as matched set and in the same orientation when re-assembling the pump.



7. The L series pumps are configured as industrial pumps with pinion shafts for internal gear reduction or as Horizontal Drill (HD) or High Volume (HV) pumps that may have direct crankshaft driven design (no pinion shaft) with provision for direct hydraulic motor mounting. If the pump is a direct crankshaft drive (no separate pinion shaft) configuration, then skip to step 10.



8. For industrial pumps and HD pumps with pinion shaft, remove the hex head cap screws (28), the left and right pinion housings (17 and 18), and shims (21) from the power frame. The gaskets (20) may adhere to the power frame surface and can be left in place if they are not damaged. Count and record the number of shims on each side to facilitate assembly. It may be necessary to tap on the housings with a rubber mallet to free the shims from the pump frame.



**The oil seal (19), and on some models, the bearing cup (25) will remain attached to the pinion housing.**

**NOTE**

9. The pinion shaft (3) with bearings may then be removed from the drive side by using a brass rod (or other soft material) and mallet to drive the shaft out. The L16 pump will allow removal without the use of a mallet.
10. The piston rod seals must be unthreaded and separated from the power end. In some cases, it may be required to remove the piston rod seals completely. For separation or removal refer to Section 10.4.1, "Replacing Piston Rod Oil Seals" for instructions.
11. Push the connecting rod (4) and crosshead assemblies (7) as far forward into the power frame as possible to provide clearance for the crankshaft. The connecting rod bolts should be removed completely to provide additional clearance when removing the crankshaft and to reduce the possibility of damage to the crankshaft journals.



**Installation Tip:** Mark the bearing housings and power frame for installation in the original position.

12. Remove the hex head cap screws (28), bearing housings (12 and 36), and shims (13) from both sides of the pump. Count and record the shims on each side to facilitate assembly. The gaskets (14) may adhere to the power frame surface and can be left in place if they are not damaged. For pump models that use o-ring seals it is recommended that the o-rings be replaced. The bearing cups (23) will remain in the bearing housing. On pumps with no pinion shaft (some HD or HV models), there will be an oil seal (19) that will remain attached to one housing. It may be necessary to tap on the housing with a rubber mallet to free it from the power frame after the hex head cap screws have been removed.
  
13. To remove the crankshaft (2) on pump models with no pinion shaft (some HD and HV), carefully move it through one side of the bearing housing opening in the power frame (1). The throws may have to be rotated as the crank is removed to clear the connecting rods. The crankshaft should be handled carefully to prevent the critical bearing surfaces from being scratched or damaged.
  
14. To remove the crankshaft on industrial pump models with a pinion shaft, work the crankshaft to the left when viewing from the rear opening of the power frame. The bearing cone (22) will be partially out of the bearing housing opening. The throws or journals may have to be rotated as the crank is removed to clear the connecting rods. On L16 pumps the throw to the right of the gear (when viewing from the rear opening in the power frame) must be toward the opening. Slip the crankshaft end on the right out the back of the power frame and remove. The crankshaft should be handled carefully to prevent the critical bearing surfaces from being scratched or damaged.

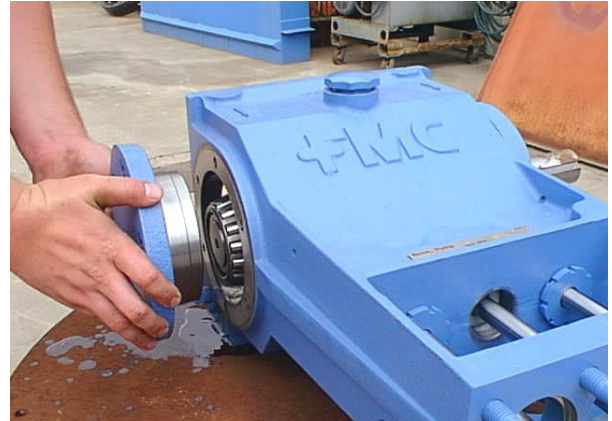



15. Bearing cones (22) may be removed from the crankshaft using an automotive type bearing puller. Bearing cups (23) can be removed from the bearing housing using a puller if a sufficient lip is available for the puller arms to grab. An alternate procedure involves running a weld bead around the inside surface of the cup. When cool, this will reduce the interference between the cup and bearing housing enough to free the cup. If either the cup or cone is replaced, the corresponding cup or cone should be replaced as they are a matched set.



16. Pull the connecting rod/crosshead assemblies (7) from the power frame. Mark each connecting rod and crosshead assembly to ensure they are reassembled into the same bore from which they were removed.

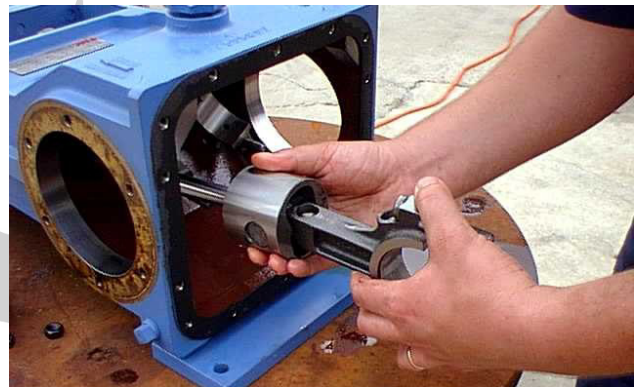

17. Remove the set screw (27) and slide the wrist pin (6) out of the crosshead (7) if crosshead or connecting rod (4) requires service. Keep components matched together.
18. Inspect all components for signs of wear or damage and replace if required. Carefully check the crankshaft bearing surfaces for pits, scratches, or other signs of wear. The connecting rod bearings should be inspected for deep scratches or to see if the top metal surface worn away.
19. If damaged, remove the crankshaft oil seal (19) using a screwdriver or similar object and discard the old seal.
20. Thoroughly clean all parts with solvent and apply a thin coat of oil before reassembly.

21. Tapered roller bearing cones (22) must be heated to aid in assembly onto the shaft. Always observe proper safety procedures and use heat resistant tools and gloves when handling hot parts. There are a number of recommended methods for heating bearings. Electric ovens or electrically heated oil baths may be used, but only when accompanied by proper thermostatic control.
22. To replace the tapered roller bearings on the crankshaft, heat the cones to a maximum of 300° F (149° C). Slide them down the shaft unit they are full seated against shoulder. The hot cone may pull away from the shoulder unless it is held in position until it cools enough to grab the shaft. Use a .001" thick feeler gauge to ensure the cone is fully seated against the shoulder after parts have cooled.
23. Use a press to seat the new cups (23) into the bearing housings. Never use new bearing cones with old bearing cups. Always use matched sets from one manufacturer.
24. Reassemble the crosshead assemblies and connecting rods. Ensure that the set screws (27) retaining the wrist pin (6) are in place (if they were removed for repair or inspection of the wrist pin bushing). Apply Loctite compound 271 (red) to the set screw before threading into the cross head (7). The set screw must engage the flat on the wrist pin. Refer to Section 11.0 for torque specifications.
25. Push the crosshead/connecting rod assemblies fully forward in power frame to provide maximum clearance for the crankshaft. Ensure crosshead assemblies are replaced in the same orientation and in the same cylinder bore they were originally.



**The oil cup pocket feeding lubricant to the wrist pin bushing is on the top of the connecting rod and should be in the up position.**

**NOTE**

26. Install crankshaft in the power frame. Take care not to scratch bearing surfaces of the crankshaft.



27. Inspect the o-ring or gasket (14) that seals the bearing housing and replace if damaged. Reinstall the shims (13) and bearing housings. As a starting point, install the same number of shims that the pump originally had prior to service work. When tightening the fasteners retaining the bearing cover, use crisscross pattern for tightening with a torque wrench.
  
28. Replace the rod bearings (5) in the connecting rod and connecting rod caps. Ensure that rod caps are properly assembled with their mating connecting rod. Torque the fasteners holding the end caps to the mating rod per the values given in Fastener Torque Requirements, Section 11.0 of this manual. Using a back and forth pattern, tighten each bolt to 1/3 torque, 2/3 torque and then to the full torque value using a torque wrench. After the cap screws are torqued, a light strike to the cap with a rubber hammer will help properly seat the rod bearings.
  
29. A dial indicator must be used to properly adjust the endplay of the crankshaft. Improper adjustment may result in excessive temperature, noise, and reduced bearing life. FMC recommends between .002" tight to .003" loose of internal axial clearance (end play) when properly assembled. The final adjustment must be verified using a dial indicator as indicated in the following steps 30 through 34.
  
30. Turn the crankshaft (2) more than two revolutions to ensure the connecting rods (4) are loose and that there is no binding in the rod bearings (5); the wrist pin (6) joints are free; and the crossheads move freely in the power frame (1).



31. Move the crankshaft to one side of the power frame using a light tap from a rubber mallet or a pry bar. Rotate the crankshaft several turns and repeat the light taps from a rubber mallet or the use of a pry bar to ensure the crankshaft is to one side.

32. Mount indicator base on the power frame with the indicator tip on a machined shoulder surface of the crankshaft (do not measure from a cast surface) and the axis of the indicator parallel to the crankshaft.



33. Set the dial indicator to zero.

34. Move the crankshaft back over to the opposite side and read bearing endplay as total indicator movement. Rotate the crankshaft several turns and repeat the effort to move the crankshaft in the direction described in this step. Repeat the dial indicator measurement. Remove or add shims as necessary to achieve proper endplay (.002" tight to .003" loose). Distribute shims equally on both bearing housings. Verify the endplay with the dial indicator per this procedure described before final assembly.

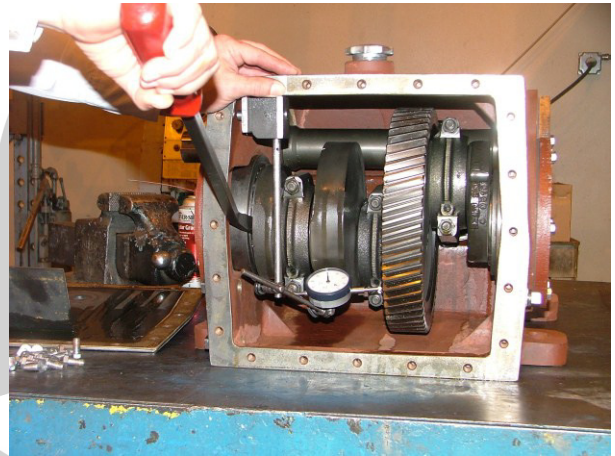

35. Install the oil seal (19) into the bearing housing. The oil seal can be installed with light hammer blows. When properly seated it will be flush with the face of the bearing housing.

36. Install the piston rod seal holder (8) and seal retainer (10) in the power frame per instructions in Section 10.4.1. The crankshaft should turn freely.

37. Complete reassembly of pump.

38. Torque all fasteners as outlined in Fastener Torque Requirements, Section 11.0 of this manual.

## 11.0 Fastener Torque Requirements

No pump service procedure is complete without ensuring that the fasteners have been properly torqued. Failure to properly tighten the pump bolts could cause the pump to leak or possibly allow the pump to fail. Always use a calibrated torque wrench during the installation of all critical fasteners listed in Table 5 below. Values are in foot-pounds (Ft-lb) and Newton meters (N-m). Typical sizes are shown in Table 5 below. Refer to Table 6 for other sizes that may be used depending on application. For torquing pattern, refer to figure 16 below.

Table 5: L Series Pump Fastener Torque Requirements

POWER END										
Item No.	Component Description	L06 & L06 HD			L09			L09 HD		
		Size	Ft-lb	(N-m)	Size	Ft-lb	(N-m)	Size	Ft-lb	(N-m)
4	Connecting Rod Bolts	0.375	30	41	0.438	45	61	0.438	45	61
43	Piston Assembly Nut	0.750	35	47	0.750	35	47	0.750	35	47
42	Piston Rod Hex Nut	0.500	35	47	0.500	35	47	0.500	35	47
28	Bearing Housing Screws	0.375	25	34	0.375	25	34	0.375	25	34
28	Pinion Housing Screws	N/A	-	-	0.375	25	34	N/A	-	-
29	Back Cover Bolts	0.375	25	34	0.375	25	34	0.375	25	34
27	Cross Head Set Screw	0.250	7	9	0.313	15	20	0.313	15	20

FLUID END										
Item No.	Component Description	L06 & L06 HD			L09			L09 HD		
		Size	Ft-lb	(N-m)	Size	Ft-lb	(N-m)	Size	Ft-lb	(N-m)
61	Cylinder Attach/Clamp Nut *	N/A	-	-	0.500	75	102	N/A	-	-
61	Cylinder Attach/Clamp Nut *	0.625	120	163	0.625	120	163	0.625	120	163
61	Cylinder Attach Bolt/Stud*	N/A	-	-	N/A	-	-	0.750	200	271
49	Valve Cover Plug	N/A	-	-	1.875	45	61	1.875	45	61
53	Valve Cover Nut *	N/A	-	-	0.500	60	81	0.500	60	81
53	Valve Cover Nut *	N/A	-	-	0.625	120	163	0.625	120	163

POWER END										
Item No.	Component Description	L11 & L11 HD			L12			L16		
		Size	Ft-lb	(N-m)	Size	Ft-lb	(N-m)	Size	Ft-lb	(N-m)
4	Connecting Rod Bolts	0.500	65	88	0.500	65	88	0.500	65	88
43	Piston Assembly Nut	0.750	35	47	0.750	35	47	0.750	35	47
42	Piston Rod Hex Nut	0.500	35	47	0.500	35	47	0.500	35	47
28	Bearing Housing Screws	0.500	60	81	0.375	25	34	0.375	25	34
28	Pinion Housing Screws	0.500	60	81	N/A	-	-	0.375	25	34
29	Back Cover Bolts	0.500	30	41	0.375	25	34	0.375	25	34
27	Cross Head Set Screw	0.313	15	20	0.313	15	20	0.313	15	20

FLUID END										
Item No.	Component Description	L11 & L11 HD			L12			L16		
		Size	Ft-lb	(N-m)	Size	Ft-lb	(N-m)	Size	Ft-lb	(N-m)
61	Cylinder Attach/Clamp Nut *	0.625	120	163	0.625	120	163	0.625	120	163
61	Cylinder Attach/Clamp Nut *	N/A	-	-	0.750	200	271	0.750	200	271
53	Valve Cover Nut *	0.500	60	81	0.500	60	81	0.500	60	81

\* For XYLAN coated studs and nuts use Table 6.

Refer to Figure 3 and Figure 4 for item numbers.

Table 6: Torque Values for Xylan-Coated Fasteners

SIZE	0.500	0.625	0.750	0.875	1.000	1.125	1.250
Ft-lb	40	80	135	215	320	460	630
(N-m)	54	108	183	292	434	624	854

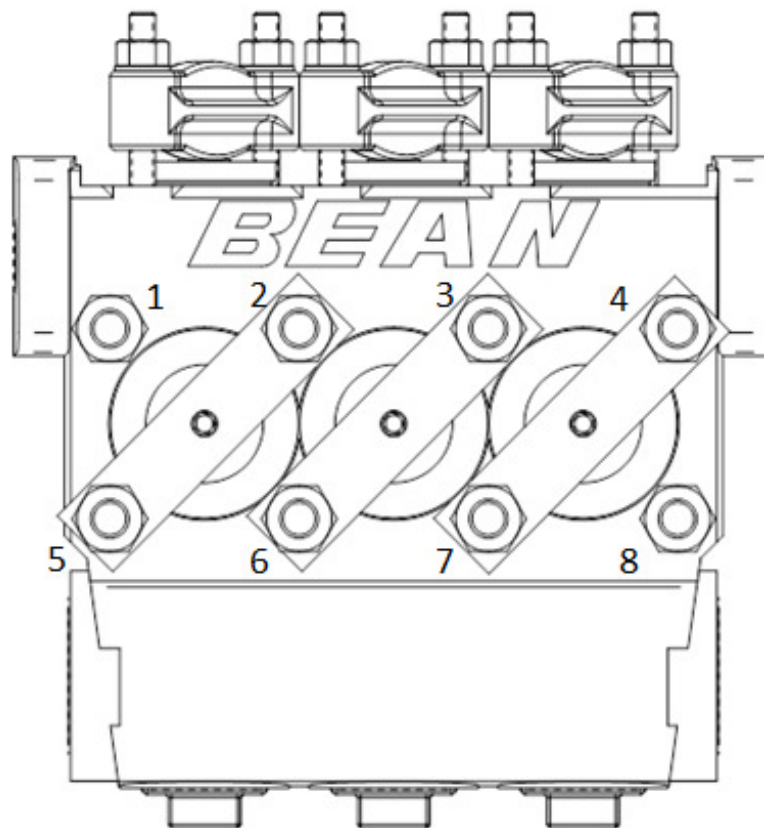

Figure 16. Identification of individual bolts, for reference in torquing sequence.

In order to torque fasteners as evenly as possible the fasteners should be brought up to the full torque value in an incremental fashion. Use the above figure and below torque sequence to torque fasteners for fluid cylinders.

Torque Sequence: 2 → 7 → 3 → 6 → 4 → 5 → 1 → 8

## 12.0 Critical Clearances

When maintenance requiring disassembly of the power end is performed, the following clearances should be checked to see if they are within factory specification or within maximum allowable limits. Additional clearance is allowed for component wear. This additional clearance is a maximum of .002 inches of total diametric wear that can be added to the clearance values in Table 7. For radial clearance, use ½ of the total diametric value.

All dimensions are shown in Inches.

Table 7: Clearance Chart

DESCRIPTION	L06	L09	L11	L12	L16
Crankshaft Throw Diameter (Stroke)	1.50	2.25	2.75	3.00	4.00
Crankshaft Pin or Journal (OD)	2.311/2.312	2.8743/2.8748	3.4990/3.4995	3.4990/3.4995	3.4990/3.4995
Connecting Rod / Crank Clearance (Max. Total)	0.003	0.003	0.003	0.003	0.003
Crosshead Diameter (OD)	2.123/2.125	2.749/2.750	3.121/3.123	3.121/3.123	3.122/3.123
Crosshead Cylinder Bore (ID)	2.126/2.128	2.7515/2.7535	3.1245/3.1260	3.1245/3.1260	3.1245/3.1260
Crosshead to Bore Clearance (Max. Total)	0.005	0.0045	0.005	0.005	0.005
Wrist Pin Bushing Bore (ID)	.8755/.8765	1.0005/1.0015	1.2505/1.2515	1.2505/1.2515	1.2505/1.2515
Wrist Pin to Bore Clearance (Max. Total)	0.002	0.002	0.002	0.002	0.002

NOTE: Clearances shown are total diametric values: For radial clearance, use ½ the value shown.

Metric Conversion: 1 inch = 25.4 mm  
1 mm = 0.03937 inches



### 13.0 Valve Removal and Installation Tools

Table 8 shows the FMC part numbers for valve removal tools for the various AR valves used in the models specified.

Table 9 on the following page shows the FMC part numbers for valve removal and installation tools for the various Disc valves used.

Table 8: AR Valve Removal Tool Guide

L06 SIZE PUMPS			
VALVE TYPE	VALVE ASSY	VALVE SIZE	REMOVAL TOOL
AR	3267563 & 326564	Series 3	P503030
AR	P533621 & P533626	Series 23	P503030
L09 SIZE PUMPS			
VALVE TYPE	VALVE ASSY	VALVE SIZE	REMOVAL TOOL
AR	3267563 & 326564	Series 3	P503030
AR	P533621 & P533626	Series 23	P503030
AR	3267652 & 5273330	Series 5	5276357
AR	P533637, P533638 & P533639	Series 25	5276357
L11 & L12 SIZE PUMPS			
VALVE TYPE	VALVE ASSY	VALVE SIZE	REMOVAL TOOL
AR	3267652 & 5273330	Series 5	5276357
AR	P533637, P533638 & P533639	Series 25	5276357
L16 SIZE PUMPS			
VALVE TYPE	VALVE ASSY	VALVE SIZE	REMOVAL TOOL
AR	3267563 & 326564	Series 3	P503030
AR	P533621 & P533626	Series 23	P503030
AR	3267652 & 5273330	Series 5	5276357
AR	P533637, P533638 & P533639	Series 25	5276357
AR	5271408 & P504356	Series 7	5276358
AR	P533509 & P533514	Series 27	5276358

Table 9: Disc Valve Removal and Installation Tool Guide

L06 SIZE PUMPS				
VALVE TYPE	VALVE ASSY	VALVE SIZE	REMOVAL TOOL	INSTALLATION TOOL
Disc	5257290	1.312 G.L. / .94 ID	P534695 (Small Ball)	P534699
Disc	5257291	1.437 G.L. / .94 ID	P534695 (Small Ball)	P534702
Disc	5272584	1.312 G.L. / .94 ID	P534695 (Small Ball)	P534699
Disc	5272585	1.437 G.L. / .94 ID	P534695 (Small Ball)	P534702
Disc	P506665	1.437 G.L. / .94 ID	P534695 (Small Ball)	P534702
Disc	P506666	1.312 G.L. / .94 ID	P534695 (Small Ball)	P534699
L09 SIZE PUMPS				
VALVE TYPE	VALVE ASSY	VALVE SIZE	REMOVAL TOOL	INSTALLATION TOOL
Disc	1256641	1.186 G.L. / .75 ID	P504436 OR P534695	P534696
L11 & L12 SIZE PUMPS				
VALVE TYPE	VALVE ASSY	VALVE SIZE	REMOVAL TOOL	INSTALLATION TOOL
Disc	1278104	1.563 G.L. / 1.09 ID	P534694 (Large Ball)	P534699 OR P534702
Disc	5255419	1.563 G.L. / 1.23 ID	P534694 (Large Ball)	P534699 OR P534702
Disc	5257585	1.563 G.L. / 1.23 ID	P534694 (Large Ball)	P534699 OR P534702
L16 SIZE PUMPS				
VALVE TYPE	VALVE ASSY	VALVE SIZE	REMOVAL TOOL	INSTALLATION TOOL
Disc	5255419	1.563 G.L. / 1.23 ID	P534694 (Large Ball)	P534699 OR P534702
Disc	5257585	1.563 G.L. / 1.23 ID	P534694 (Large Ball)	P534699 OR P534702

NOTE: G.L. = Gage Line

**BUCKHORN  
PUMPS, INC.**

## 14.0 Trouble-Shooting Pumps

This chart is designed to aid in the solution of pump and pump system problems. Once the problem has been identified, work through the possible causes and solutions until the problem has been corrected.

SYMPTOM	POSSIBLE CAUSE	REMEDY
No flow from pump	<ul style="list-style-type: none"> <li>-No liquid in reservoir (tank)</li> <li>-Inlet line valve closed</li> <li>-Inlet strainer is totally clogged with debris</li> <li>-Crankshaft is not turning</li> </ul>	<ul style="list-style-type: none"> <li>-Ensure lines are connected and fill tank</li> <li>-Ensure lines are connected and open valve</li> <li>-Clean or replace strainer</li> <li>-Check for power to drive and drive connections</li> </ul>
Insufficient pressure from pump (ONLY)	<ul style="list-style-type: none"> <li>-Pump speed is too low</li> <li>-Relief valve improperly adjusted or worn</li> <li>-Insufficient system resistance (worn nozzle)</li> <li>-Worn check valves</li> <li>-Excessive leakage from pump seals</li> </ul>	<ul style="list-style-type: none"> <li>-Check belt tightness or power to motor</li> <li>-Check relief valve and adjust setting</li> <li>-Properly service system</li> <li>-Inspect check valves and repair or replace</li> <li>-Adjust or replace packing or damaged parts</li> </ul>
Insufficient flow from pump (ONLY)	<ul style="list-style-type: none"> <li>-Pump speed is too low</li> <li>-Relief valve improperly adjusted or worn</li> <li>-Worn pump valves</li> <li>-Excessive leakage from pump seals</li> <li>-Plunger or piston worn</li> <li>-Valve seat washed out in fluid cylinder</li> </ul>	<ul style="list-style-type: none"> <li>-Check belt tightness or power to motor</li> <li>-Check relief valve and adjust setting</li> <li>-Inspect pump valves and repair or replace</li> <li>-Adjust or replace packing or damaged parts</li> <li>-Replace plunger or piston</li> <li>-Repair or replace fluid cylinder</li> </ul>
Insufficient flow or pressure AND rough operation (pump pounds or vibrates)	<ul style="list-style-type: none"> <li>-All pump cylinders not primed</li> <li>-By-pass or relief is piped back to suction</li> <li>-Inlet line too long or too small in diameter</li> <li>-Insufficient NPSHA</li> <li>-Air leaks in suction line or fittings</li> <li>-Vortex in tank near inlet pipe opening</li> <li>-Air entering booster pump</li> <li>-Pump valve stuck open or closed</li> <li>-Valve assembly damaged or unseated</li> <li>-Valve seat washed out in fluid cylinder</li> <li>-Gas pocket formation from high spots in suction</li> </ul>	<ul style="list-style-type: none"> <li>-Prime all chambers</li> <li>-Pipe back to reservoir (tank)</li> <li>-Increase suction pipe size</li> <li>-Provide more NPSH</li> <li>-Correct installation to stop leaks</li> <li>-Increase submergence or baffle to stop vortex</li> <li>-Correct installation of booster pump</li> <li>-Clean and deburr valve</li> <li>-Properly seat or repair valve</li> <li>-Repair or replace fluid cylinder</li> <li>-Correct suction line installation</li> </ul>



Pump runs rough, knocks, or vibrates (ONLY)	<ul style="list-style-type: none"> <li>-Broken or weak valve spring</li> <li>-Valve damaged or unseated</li> <li>-Loose plunger, piston, or rod</li> <li>-Low oil level in power end</li> <li>-Excessive connecting rod bearing clearance</li> <li>-Excessive main bearing clearance</li> <li>-Worn wrist pin or bearing</li> <li>-Pump running backward</li> <li>-Loose sheaves or bushings (v-belt drive)</li> <li>-Gear tooth cracked or broken</li> <li>-Insufficient NPSHa</li> <li>-Excessive acceleration head in suction line</li> <li>-Pulsation dampener improperly charged</li> <li>-Inlet line too long or too small in diameter</li> <li>-Worn piston seal allows air ingress (usually observed when booster not used)</li> </ul>	<ul style="list-style-type: none"> <li>-Replace valve spring</li> <li>-Repair/replace valve or re-seat</li> <li>-Tighten loose components</li> <li>-Fill to proper level</li> <li>-Check cap torque or replace bearings</li> <li>-Adjust end-play</li> <li>-Replace worn components</li> <li>-Correct rotation</li> <li>-Tighten loose components</li> <li>-Replace gear</li> <li>-Provide more NPSH</li> <li>-Install suction stabilizer</li> <li>-Charge to proper pressure</li> <li>-Increase suction pipe size</li> <li>-Replace piston seal</li> </ul>
Rapid suction pressure fluctuation	<ul style="list-style-type: none"> <li>-Pump cavitation</li> <li>-Air is entering suction line</li> </ul>	<ul style="list-style-type: none"> <li>-Increase suction size or NPSH</li> <li>-Correct installation to stop leaks</li> </ul>
Piping vibration	<ul style="list-style-type: none"> <li>-Same as Pump runs rough above</li> <li>-Excessive pressure variation in discharge</li> <li>-Piping inadequately supported</li> <li>-Excessive short-radius elbows or tees</li> </ul>	<ul style="list-style-type: none"> <li>-See above</li> <li>-Install discharge pulsation dampener</li> <li>-Install supports at proper locations</li> <li>-Correct installation to minimize turns and short-radius fittings</li> </ul>
Pump requires excessive power	<ul style="list-style-type: none"> <li>-Discharge pressure too high</li> <li>-Plungers or pistons too large</li> <li>-Speed too high</li> <li>-Packing too tight</li> <li>-Misaligned coupling</li> <li>-Belts too tight</li> <li>-Power end bearings too tight</li> <li>-Low motor voltage</li> </ul>	<ul style="list-style-type: none"> <li>-Reduce system back-pressure or relief valve</li> <li>-Install smaller plungers to reduce flow</li> <li>-Reduce speed</li> <li>-Loosen gland (Adjustable packing)</li> <li>-Correct alignment</li> <li>-Correctly adjust belt tension</li> <li>-Increase end-play</li> <li>-Supply correct voltage</li> </ul>
Power end overheats (over 180° F) and/or reduced power component end life	<ul style="list-style-type: none"> <li>-Discharge and/or suction pressure too high</li> <li>-Oil level too high or too low</li> <li>-Contaminated power end oil</li> <li>-Incorrect oil viscosity or grade</li> <li>-Misaligned coupling</li> <li>-Belts too tight</li> <li>-Pump running backward</li> <li>-Pump located too close to heat source</li> <li>-Worn or damaged power end bearings</li> </ul>	<ul style="list-style-type: none"> <li>-Reduce pressure or reduce plunger size</li> <li>-Adjust to correct oil level</li> <li>-Refill with clean oil &amp; eliminate contamination</li> <li>-Fill with correct oil</li> <li>-Correct alignment</li> <li>-Correctly adjust belt tension</li> <li>-Correct rotation</li> <li>-Remove heat source or insulate power end</li> <li>-Replace damaged bearings</li> </ul>
Crankshaft jerks or starts and stops rotation	<ul style="list-style-type: none"> <li>-Drive belts loose and slipping (if equipped)</li> <li>-System relief valve pressure set too high</li> <li>-Discharge line blocked or partially blocked</li> </ul>	<ul style="list-style-type: none"> <li>-Correctly adjust belt tension</li> <li>-Reduce relief valve pressure setting</li> <li>-Clear obstructions from piping system</li> </ul>

Fluid leaking from pump	<ul style="list-style-type: none"> <li>-Piston cups are worn</li> <li>-Piston to rod o-ring damaged</li> <li>-Fluid cylinder bolts not properly tightened</li> <li>-Fluid cylinder o-rings (or gaskets) damaged</li> </ul>	<ul style="list-style-type: none"> <li>-Replace piston cup</li> <li>-Replace o-ring</li> <li>-Properly tighten and torque bolts</li> <li>-Replace damaged o-rings or gaskets</li> </ul>
Reduced packing or piston cup life	<ul style="list-style-type: none"> <li>-Highly abrasive particles in fluid</li> <li>-Packing or piston cups run dry</li> <li>-Incorrect packing or cups for fluid type</li> <li>-Inadequate packing lubrication</li> <li>-Pump was run dry for extended time</li> <li>-Plunger (or rod) misaligned to stuffing box</li> <li>-Worn plunger or cup holder</li> <li>-Worn cylinder liner bore</li> <li>-Packing gland too tight (adjustable)</li> <li>-Packing gland too loose (adjustable)</li> <li>-Too much packing in box</li> <li>-Broken or weak spring</li> </ul>	<ul style="list-style-type: none"> <li>-Install strainer or filter</li> <li>-Correct problem &amp; replace packing or cup</li> <li>-Change to correct packing or cup</li> <li>-Correct problem and replace packing</li> <li>-Correct problem and replace cups</li> <li>-Correct alignment</li> <li>-Replace plunger or cup holder</li> <li>-Replace cylinder liner</li> <li>-Properly adjust gland nut</li> <li>-Properly adjust gland nut</li> <li>-Correct installation problem</li> <li>-Replace spring</li> </ul>
Reduced valve life	<ul style="list-style-type: none"> <li>-Highly abrasive particles in fluid</li> <li>-Cavitation damage</li> <li>-Air leaking into suction line or stuffing box</li> <li>-Suction inlet insufficiently submerged</li> <li>-Relief valve or bypass piped to suction</li> <li>-Valve damaged by improper installation</li> </ul>	<ul style="list-style-type: none"> <li>-Install strainer or filter</li> <li>-Correct problem and replace damaged valves</li> <li>-Correct problem and replace damaged valves</li> <li>-Increase submergence or baffle to stop vortex</li> <li>-Pipe back to reservoir (tank)</li> <li>-Replace damaged components</li> </ul>
Cracked fluid cylinder or broken fluid end bolts	<ul style="list-style-type: none"> <li>-Discharge pressure too high</li> <li>-Hydraulic shock (cavitation or entrained air)</li> <li>-Discharge valve stuck closed</li> <li>-Fluid freezing in fluid cylinder</li> <li>-Material or manufacturing defect</li> <li>-Bolt or nut not properly torqued</li> <li>-Excessive piping loads on fluid end</li> </ul>	<ul style="list-style-type: none"> <li>-Reduce system back pressure or relief valve</li> <li>-Correct piping system problem</li> <li>-Replace damaged components</li> <li>-Change procedure to drain fluid when cold</li> <li>-Replace defective component</li> <li>-Replace fluid cylinder and properly torque</li> <li>-Add supports to piping</li> </ul>
Broken crankshaft or connecting rod	<ul style="list-style-type: none"> <li>-Discharge pressure too high</li> <li>-Suction pressure too high</li> <li>-Fluid freezing in fluid end</li> <li>-Hydraulic shock due to cavitation</li> <li>-Material or manufacturing defect</li> </ul>	<ul style="list-style-type: none"> <li>-Reduce system back pressure or relief valve</li> <li>-Reduce suction pressure or plunger diameter</li> <li>-Change procedure to drain fluid when cold</li> <li>-Correct piping system problems</li> <li>-Replace defective components</li> </ul>
Power end oil is contaminated	<ul style="list-style-type: none"> <li>-Extended operation with failed piston cup</li> <li>-Hi-press wash wand near breather or seals</li> <li>-Deflector shields are missing or damaged</li> <li>-Crosshead extension seals damaged</li> <li>-Excessive capacity in liner wash system</li> <li>-Improperly adjusted liner wash nozzle</li> </ul>	<ul style="list-style-type: none"> <li>-Replace piston cup and improve monitoring</li> <li>-Provide shields to protect breather and seals</li> <li>-Repair or replace deflector shields</li> <li>-Replace oil seals</li> <li>-Reduce capacity in liner wash system</li> <li>-Adjust liner wash nozzle</li> </ul>



## 15.0 Ordering Parts

Service parts are available through FMC's worldwide network of distributors or from the original supplier for the equipment that the pump is a component of. If unsure where to purchase parts, contact FMC customer service for the location of an authorized parts retailer in your area.

Always insist on genuine FMC replacement parts.

Use the assembly drawing and bill of material included with this manual to determine the components and corresponding part numbers required to service the pump. Make sure that the part number on the drawing or bill of material matches the part number of the pump requiring parts.



**When ordering parts, always reference the part number and serial number of the pump with the order.**

### NOTE

---

These part and serial numbers can be found stamped on the metal name tag affixed to the power end of every pump. By referencing these numbers you can ensure that the components you receive work as intended with your pump.

Be sure to inquire about any special service tools or complete maintenance kits.

BUCKHORN  
PUMPS, INC.

## 16.0 Glossary of Commonly Used Terms

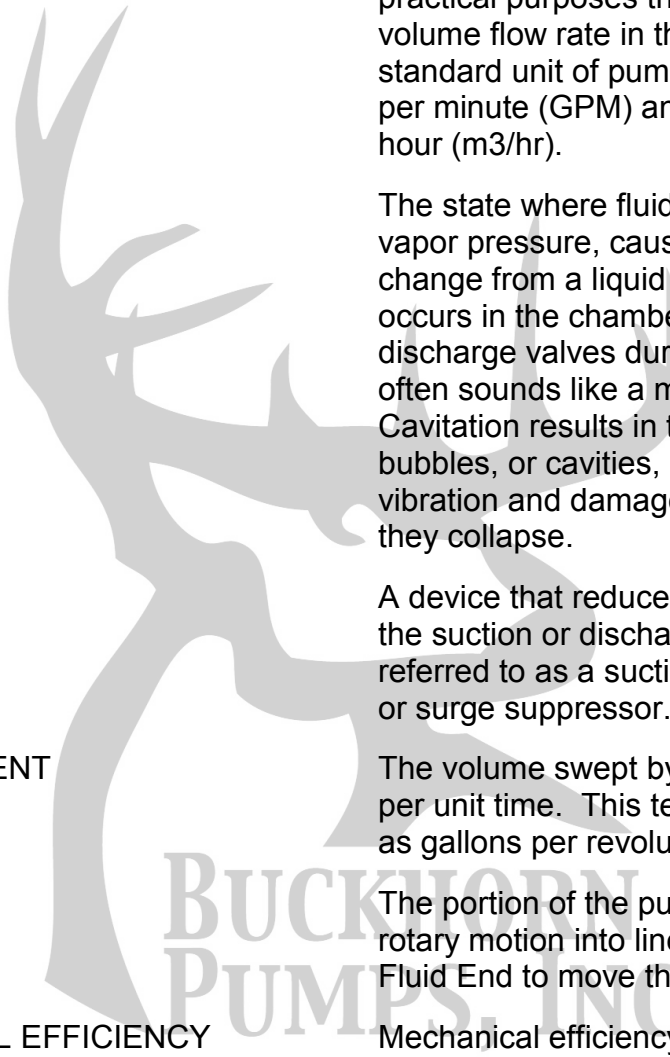

CAPACITY	The total volume throughput per unit of time at suction conditions. It includes both liquid and any dissolved or entrained gases. For all practical purposes this can be considered the volume flow rate in the suction pipe. The standard unit of pump capacity is U.S. gallons per minute (GPM) and metric cubic meters per hour (m <sup>3</sup> /hr).
CAVITATION	The state where fluid pressure drops below vapor pressure, causing the liquid to begin to change from a liquid to a gas and boil. Usually occurs in the chamber between the suction and discharge valves during the suction stroke, and often sounds like a mechanical knock. Cavitation results in the formation of gas bubbles, or cavities, in the fluid that cause vibration and damage to components when they collapse.
DAMPENER	A device that reduces pressure pulsations in the suction or discharge piping. This may be referred to as a suction stabilizer, accumulator, or surge suppressor.
DISPLACEMENT	The volume swept by all pistons or plungers per unit time. This term is typically expressed as gallons per revolution.
POWER END	The portion of the pump that converts supplied rotary motion into linear motion used by the Fluid End to move the pumpage.
MECHANICAL EFFICIENCY	Mechanical efficiency (ME) is the ratio, expressed as a percentage, of pump power output to the pump power input. The mechanical efficiency of reciprocating pumps is very high, typically 85% to 90%.
VOLUMETRIC EFFICIENCY	Volumetric efficiency (VE) is the ratio of actual pump capacity output to theoretical displacement. The volumetric efficiency is

	affected by the fluid being pumped and the discharge pressure.
FLOODED SUCTION	Implies that the level of liquid in the suction vessel is above the centerline of the suction port of the pump.
FLUID END	The portion of the pump that converts the linear motion supplied by the power end into fluid flow at pressure. This may also be called the Liquid End. It is called a valve chamber in old literature.
NPSHa	An abbreviation that stands for Net Positive Suction Head Available. NPSHa is the total suction pressure, including allowance for acceleration head, available from the system at the pump suction connection, minus the vapor pressure of the liquid at actual pumping temperature. NPSHa for a reciprocating pump is normally expressed in units of feet of water.
NPSHr	An abbreviation that stands for "Net Positive Suction Head Required". This is the minimum total inlet pressure required by the pump for proper operation. This value is a function of pump design and speed and is determined by the pump manufacturer through a specific NPSH test. NPSHa should exceed NPSHr by approximately 5 feet.
PISTON	A type of power pump that uses a cylindrical seal (piston) mounted on a holder to drive fluid through the valves. The piston seal reciprocates within a stationary cylinder.
PLUNGER	A type of power pump that uses a cylindrical plunger to drive fluid through the valves. The plunger reciprocates through a stationary set of seals known as packing.
POWER PUMP	A reciprocating pump that drives the pumping element(s) using a slider crank mechanism. Power pumps are piston, plunger, or diaphragm type. All require a driver with a rotating shaft, such as a motor or engine, as a power source.

**POWER FRAME**

The major portion of a power pump that encloses and supports all other components of the power (or drive) end. It is called a pump case in old literature.

**STROKE LENGTH**

The length of one complete, unidirectional motion of the piston or plunger. Stroke length is usually expressed in inches.

**PUMP VALVE**

A check valve that allows flow of liquid in one direction. FMC pumps have a series of two valves, one suction (inlet) and one discharge, per pumping cylinder.



## 17.0 Reference Information

Use the following section to record key information about your specific pump model. Information such as part and serial numbers will be needed when ordering service parts. This data may be found stamped on the metal nameplate located on the pump power frame. This area may also be used to make notations about special parts, procedures, phone numbers, or other important information related to your pump.

Pump Model \_\_\_\_\_

Part Number \_\_\_\_\_

Serial Number \_\_\_\_\_

Rated Pressure \_\_\_\_\_

Rated Capacity \_\_\_\_\_

Rated Speed \_\_\_\_\_

Notes:

